Gas welding equipment — Pressure regulators and pressure regulators with flow-metering devices for gas cylinders used in welding, cutting and allied processes up to 300 bar (30 MPa)

Matériel de soudage aux gaz — Détendeurs et détendeurs débitmètres intégrés pour bouteilles de gaz utilisés pour le soudage, le coupage et les techniques connexes jusqu'à 300 bar (30 MPa)



Reference number
ISO 2503:2009(E)

© ISO 2009

PDF disclaimer

This PDF file may contain embedded typefaces. In accordance with Adobe's licensing policy, this file may be printed or viewed but shall not be edited unless the typefaces which are embedded are licensed to and installed on the computer performing the editing. In downloading this file, parties accept therein the responsibility of not infringing Adobe's licensing policy. The ISO Central Secretariat accepts no liability in this area.

Adobe is a trademark of Adobe Systems Incorporated.

Details of the software products used to create this PDF file can be found in the General Info relative to the file; the PDF-creation parameters were optimized for printing. Every care has been taken to ensure that the file is suitable for use by ISO member bodies. In the unlikely event that a problem relating to it is found, please inform the Central Secretariat at the address given below.



COPYRIGHT PROTECTED DOCUMENT

© ISO 2009

All rights reserved. Unless otherwise specified, no part of this publication may be reproduced or utilized in any form or by any means, electronic or mechanical, including photocopying and microfilm, without permission in writing from either ISO at the address below or ISO's member body in the country of the requester.

ISO copyright office
Case postale 56 • CH-1211 Geneva 20
Tel. + 41 22 749 01 11
Fax + 41 22 749 09 47
E-mail copyright@iso.org
Web www.iso.org

Published in Switzerland

Contents

Page

Foreword	iv
1 Scope	1
2 Normative references	2
3 Terms and definitions	2
4 Symbols and abbreviated terms	4
5 Design requirements	4
5.1 Materials	4
5.2 Design and construction	4
6 Physical performance and operating characteristics	7
6.1 Pressures	7
6.2 Flow rates for pressure regulators without flow-metering devices	7
6.3 Equipment classes for pressure regulators without flow-metering devices	7
6.4 Pressure-relief valve	9
6.5 Operating-temperature range	9
6.6 Performance and operating characteristics	9
7 Marking	11
7.1 Pressure regulators without flow-metering devices	11
7.2 Pressure regulators with flow-metering devices	11
8 Instructions for use	12
9 Type-test procedure	12
9.1 General	12
9.2 Test samples and necessary documents	13
9.3 Test conditions	13
9.4 Units	13
9.5 Test for performance and operating characteristics of pressure regulators without flow-metering devices	14
9.6 Test for performance and operating characteristics of pressure regulator with flow-metering devices	17
9.7 Tests for mechanical resistance of pressure regulators or pressure regulator with a flow-metering device	19
9.8 Test for durability of markings	23
Annex A (informative) Pressure regulators	24
Annex B (informative) Operating principles of pressure regulators with flow-metering devices	28
Bibliography	30

Foreword

ISO (the International Organization for Standardization) is a worldwide federation of national standards bodies (ISO member bodies). The work of preparing International Standards is normally carried out through ISO technical committees. Each member body interested in a subject for which a technical committee has been established has the right to be represented on that committee. International organizations, governmental and non-governmental, in liaison with ISO, also take part in the work. ISO collaborates closely with the International Electrotechnical Commission (IEC) on all matters of electrotechnical standardization.

International Standards are drafted in accordance with the rules given in the ISO/IEC Directives, Part 2.

The main task of technical committees is to prepare International Standards. Draft International Standards adopted by the technical committees are circulated to the member bodies for voting. Publication as an International Standard requires approval by at least 75 % of the member bodies casting a vote.

Attention is drawn to the possibility that some of the elements of this document may be the subject of patent rights. ISO shall not be held responsible for identifying any or all such patent rights.

ISO 2503 was prepared by Technical Committee ISO/TC 44, *Welding and allied processes*, Subcommittee SC 8, *Equipment for gas welding, cutting and allied processes*.

This third edition cancels and replaces the second edition (ISO 2503:1998), and also ISO 7292:1997, which have been technically revised.

Requests for official interpretations of any aspect of this International Standard should be directed to the Secretariat of ISO/TC 44/SC 8 via your national standards body. A complete listing of these bodies can be found at www.iso.org.

Gas welding equipment — Pressure regulators and pressure regulators with flow-metering devices for gas cylinders used in welding, cutting and allied processes up to 300 bar (30 MPa)

1 Scope

This International Standard specifies requirements for single or two-stage pressure regulators without flow-metering devices for connection to gas cylinders used for

- compressed gases up to 300 bar ¹⁾ (30 MPa),
- dissolved acetylene,
- liquefied petroleum gases (LPG),
- methylacetylene-propadiene mixtures (MPS), and
- carbon dioxide (CO₂),

for use in welding, cutting and allied processes. It does not cover pressure regulators having a nominal outlet pressure $p_2 > 20$ bar.

This International Standard also specifies requirements for single or two-stage pressure regulators with flow-metering devices for connection to gas cylinders used for

- compressed gases or mixtures up to 300 bar (30 MPa), and
- carbon dioxide (CO₂),

for use in welding, cutting and allied processes. Typical processes using this equipment are: tungsten inert-gas arc welding (TIG), metal-arc inert-gas welding (MIG), metal-arc active-gas welding (MAG), plasma arc welding, tubular-cored-wire/tubular-cored-wire welding and plasma cutting. Annex B gives examples of flow-control systems and their flow-measuring devices.

This International Standard does not cover pressure regulators intended for direct use on cylinder bundles. Such regulators comply with the safety requirements of ISO 7291, in particular with the adiabatic compression test for oxygen regulators.

NOTE In addition to terms used in English and French, two of the three official ISO languages (English, French and Russian), this document gives the equivalent terms in German; these are published under the responsibility of the member body for Germany (DIN), and are given for information only. Only the terms and definitions given in the official languages can be considered as ISO terms and definitions.

1) 300 bar relates to the maximum cylinder filling pressure at 15 °C.

2 Normative references

The following referenced documents are indispensable for the application of this document. For dated references, only the edition cited applies. For undated references, the latest edition of the referenced document (including any amendments) applies.

ISO 554, *Standard atmospheres for conditioning and/or testing — Specifications*

ISO 5145, *Cylinder valve outlets for gases and gas mixtures — Selection and dimensioning*

ISO 5171, *Gas welding equipment — Pressure gauges used in welding, cutting and allied processes*

ISO/TR 7470, *Valve outlets for gas cylinders — List of provisions which are either standardized or in use*

ISO 9090, *Gas tightness of equipment for gas welding and allied processes*

ISO 9539, *Materials for equipment used in gas welding, cutting and allied processes*

ISO 15296, *Gas welding equipment — Vocabulary — Terms used for gas welding equipment*

3 Terms and definitions

For the purposes of this document, the terms and definitions given in ISO 15296 and the following apply.

3.1

accuracy of a flow-metering device

classification based on the permissible error of the flow indication of the device

3.2

adjustable pressure regulators

pressure regulator that is provided with a means of operator adjustment at the outlet pressure

NOTE See A.1.

3.3

fixed orifice

device, which delivers but does not indicate, a known flow when supplied with a constant upstream pressure and facing no significant back pressure

3.4

flow gauge

device which measures pressure and which is calibrated in units of flow

NOTE The flow gauge does not measure flow. It indicates flow by measuring the pressure upstream of a fixed orifice.

3.5

flow meter

device that measures and indicates the flow of a specific gas or gas mixture

3.6

indicated flow(s)

flow(s) indicated on the measuring device of a pressure regulator with a flow-metering device

3.7**maximum intermediate pressure** p_{2m}

for pressure regulators with flow-metering devices, maximum pressure specified by the manufacturer and measured in the intermediate pressure chamber, downstream of the pressure-regulator valve and upstream of the flow-adjusting and measuring device

NOTE This maximum pressure is defined for the pressure-regulator tests, and is above the normal operating pressure of the flow meter.

3.8**nominal discharge** Q_n

for pressure regulators with flow-metering devices, discharge specified by the manufacturer (measured downstream of the flow-adjusting and measuring devices)

3.9**permissible error of the flow indication**

difference between the indicated flow and the true flow, as a percentage of the indicated flow

3.10**preset pressure regulator**

pressure regulator that is not provided with a means of operator adjustment at the outlet pressure

NOTE See A.2.

3.11**pressure gauge**

device that measures and indicates pressure

3.12**pressure regulator**

device for regulating a generally variable inlet pressure to an outlet pressure that is as constant as possible

NOTE See A.1.

3.13**pressure regulator with flow-metering devices**

device for regulating a generally variable inlet gas pressure to an outlet pressure that is as constant as possible, ensuring in addition a selected gas flow

NOTE 1 See A.2.

NOTE 2 It is generally a pressure regulator equipped with flow-adjusting and measuring devices which are not intended to be separated from the regulating device by the operator.

3.14**stability of the flow-metering device**

ability of a flow-metering device, when at a given flow setting, to deliver flows at any inlet pressure close to the true value of the flow delivered at the nominal pressure p_1

3.15**true flow**

flow measured with a calibrated measuring device

4 Symbols and abbreviated terms

The symbols used in this International Standard are given in Table 1.

Table 1 — Symbols and definitions

Symbol	Definition
p_1	nominal inlet pressure specified by the manufacturer, see Table 3 for preferred values
p_2	nominal outlet pressure specified by the manufacturer, see Table 3 for preferred values
p_{2R}	acetylene outlet pressure used for calculation of R (see 9.5.3.3)
p_{2i}	acetylene outlet pressure used for calculation of i (see 9.5.5.3)
p_{2m}	maximum intermediate pressure
p_3	upstream pressure for type testing: $p_3 = 2_{p_2} + 1$ bar (0,1 MPa)
p_4	closing pressure after stopping the standard discharge
p_5	highest or lowest outlet pressure during a test for determination of irregularity coefficient in accordance with 6.6.1.2
p_{RV}	pressure for the pressure-relief valve during discharge test, see 6.4.1
Q_1	standard discharge (equipment classes), see Table 3
Q_n	nominal discharge (of a pressure regulator with a flow-metering device), specified by the manufacturer
Q_{max}	maximum discharge
Q_{RV}	discharge of the pressure-relief valve
R	coefficient of pressure increase upon closure
i	irregularity coefficient

5 Design requirements

5.1 Materials

Materials for pressure regulators and pressure regulators with flow-metering devices shall conform to the requirements of ISO 9539.

5.2 Design and construction

5.2.1 Oxygen pressure regulators

Pressure regulators for oxygen shall be designed and manufactured while giving consideration to the possibility for internal ignition. Pressure regulators for oxygen shall not ignite or show evidence of burning when submitted to the ignition test in 9.7.4.

All components and accessories shall be thoroughly cleaned and degreased before assembly.

5.2.2 Acetylene pressure regulators

Pressure regulators for acetylene shall be designed and manufactured so that the stabilized outlet pressure shall not exceed 1,5 bar for all inlet pressures.

5.2.3 Connections

5.2.3.1 Inlet connections

Pressure regulators and pressure regulators with flow-metering devices shall be made in such a way that the inlet connection is compatible with the cylinder valve outlet and designated for the intended gas service in accordance with ISO 5145, regional and national standards²⁾. The inlet pressure p_1 specified by the manufacturer, shall not be less than the maximum filling pressure (at 15 °C) allowed for the gas-cylinder connection.

5.2.3.2 Outlet connections

Threaded outlet connections shall comply with the national standard or regulatory requirements of the country where they are used. If no national standard is enforced, it is recommended that the connection comply with ISO/TR 28821. The connections will comply with the following conditions:

- the outlet-connection orientation should preferably point downwards and away from the gas cylinder;
- curved hose tails shall not be used.

5.2.4 Filter

A particle filter, having an effective cross-section compatible with the discharge, shall be mounted within the pressure regulator upstream of the pressure-regulator valve. The filter shall not be removable without the use of a tool. The filter shall retain particles greater or equal to 0,1 mm.

5.2.5 Outlet shut-off valve

Pressure regulators may be fitted with an outlet shut-off valve. When fitted, the spindle shall be captive.

5.2.6 Pressure-adjusting device

This device shall be designed in such a way that it is not possible for the pressure-regulator valve to be held in the open position, for example, as a consequence of the spring being compressed fully (to its solid length).

If prevention of the spring becoming fully compressed depends on the dimensions of the pressure-adjusting screw, then the screw shall be not removable.

Using the pressure-adjusting device, it shall not be possible to set a pressure at which the pressure-relief valve opens.

5.2.7 Flow-control valve

A pressure regulator with a flow-metering device may be fitted with a flow-control valve. The flow-control knob and the valve spindle shall be captive such that they cannot be dismantled without the use of a tool.

5.2.8 Pressure-relief device

All pressure regulators, except those for acetylene or LPG, shall be supplied with a pressure-relief device (e.g. pressure-relief valve or burst disc) designed to vent excess outlet pressure in the case of partial regulator-seat malfunction. It shall be demonstrated that a sufficient level of safety is ensured in accordance with 5.2.11.2. A safety-risk analysis or special safety precautions shall be considered.

2) See ISO/TR 7470.

5.2.9 Pressure gauges

If pressure gauges or flow gauges are used, they shall conform to ISO 5171. If pressure gauges or flow gauges are integral with the pressure regulator or the pressure regulator with a flow-metering device, the relevant operational and safety requirements shall be specified.

5.2.10 Leakage

5.2.10.1 General

Pressure regulators and pressure regulators with flow-metering devices shall be gas tight to the atmosphere.

5.2.10.2 External leakage

Pressure regulators and pressure regulators with flow-metering devices shall be externally gas tight for all normal pressures for relevant gases. Regulators shall not have a leakage rate greater than 0,17 mbar l/min (10 cm³/h).

This requirement is given in ISO 9090, together with suitable test methods.

5.2.10.3 Internal Leakage

Pressure regulators and pressure regulators with flow-metering devices shall be internally gas tight, i.e. between the high-pressure and low-pressure parts for all normal pressures for relevant gases. The maximum leakage shall not exceed 0,2 mbar l/min (12 cm³/h).

5.2.11 Mechanical resistance

5.2.11.1 Resistance to internal pressure

Pressure regulators and pressure regulators with flow-metering devices shall be designed and constructed in such a way that the application of pressures given in Table 2 in the high-pressure and low-pressure-regulator chambers does not lead to permanent deformation.

Table 2 — Test pressures

Gas	High-pressure chambers	Low-pressure chambers
Oxygen and other compressed gases, including classes 0, 1, 2, 3, 4 and 5	$1,5 \times p_1$	60 bar (6 MPa)
Acetylene, including classes 1 and 2	300 bar (30 MPa)	30 bar (3 MPa)
LPG and MPS, including classes 0 and 1		60 bar (6 MPa)
CO ₂ , including classes 0 and 1		

Pressure regulators and pressure regulators with flow-metering devices shall comply with the test in 9.7.2.1.

5.2.11.2 Pressure retention of the low-pressure side of the pressure regulator

Pressure regulators shall be designed and constructed so that, if the low-pressure chamber of the pressure regulator, or intermediate chamber in the case of two-stage pressure regulators, is in direct communication with a full cylinder of gas, for example, if the regulator pressure valve is held in the open position and the outlet connection is closed by an attached stop valve or a blind plug, the high-pressure gas shall either be safely retained or vented.

Pressure regulators and pressure regulators with flow-metering devices shall comply with the test in 9.7.2.2.

6 Physical performance and operating characteristics

6.1 Pressures

6.1.1 Nominal inlet pressure p_1

The nominal inlet pressure shall be specified by the manufacturer in accordance with Table 3.

NOTE p_1 is related to the cylinder filling pressure at 15 °C.

6.1.2 Nominal outlet pressure p_2 , for pressure regulators without flow-metering devices

The nominal outlet pressure p_2 for the standard discharge Q_1 shall be specified by the manufacturer (see Table 3 for preferred values).

6.1.3 Outlet pressures for acetylene pressure regulators of class 2 without flow-metering devices

For acetylene pressure regulators of class 2, the outlet pressures p_2 , p_4 and p_5 shall not exceed 1,5 bar.

6.2 Flow rates for pressure regulators without flow-metering devices

6.2.1 Standard discharge Q_1

Performance shall be measured at a standard discharge Q_1 , expressed in m³/h, and related to the outlet pressure p_2 , from the preferred values in Table 3 or nominated by the manufacturer, which the pressure regulator can provide at the outlet pressure p_2 and an upstream pressure p_3 given by the expression

$$p_3 = 2p_2 + 1 \text{ bar} \quad (1)$$

For acetylene pressure regulators of class 2, the standard discharge Q_1 shall be measured at p_{2R} .

6.2.2 Maximum discharge Q_{\max}

The maximum discharge Q_{\max} of the gas intended for use, expressed in m³/h, which the pressure regulator can provide, at the outlet pressure p_2 [excluding acetylene regulators of class 2, see Figure 1a)], for the upstream pressure p_3 (see 6.2.1).

For acetylene pressure regulators of class 2, the maximum discharge Q_{\max} shall be measured at the lowest outlet pressure, see Figure 1b).

The maximum discharge Q_{\max} shall be not less than the standard discharge Q_1 (see 6.2.1).

6.3 Equipment classes for pressure regulators without flow-metering devices

Performance is measured at the standard discharge Q_1 and nominated outlet pressure specified by the manufacturer.

Preferred values of p_2 and Q_1 are given in Table 3, but other values may be specified by the manufacturer.

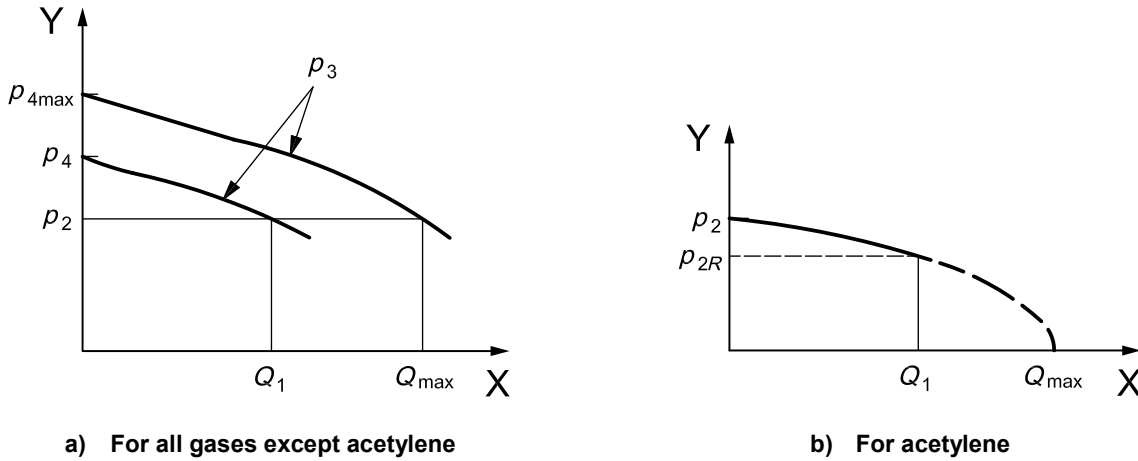

Key

- X flow rate
- Y outlet pressure

Figure 1 — Flow rate characteristics

Table 3 — Equipment classes

Gas	Class	Nominal inlet pressure p_1 bar (10^{-1} MPa)	Nominal outlet pressure p_2 bar (10^{-1} MPa)	Standard discharge Q_1 m ³ /h
oxygen and other compressed gases up to 300 bar (30 MPa)	0	0 to 300 ^a	2	1,5
	1		4	5
	2		6	15
	3		10	30
	4		12,5	40
	5		20	50
dissolved acetylene	1	25	0,8	1
	2		< 1,5	5 ^b
MPS	0	25 ^c	1,5	1
	1		4	5
LPG	0	25 ^d	1,5	1 ^e
	1		4	5 ^e
CO ₂	0	200 ^f	2	2 ^e
	1		4	2 ^e

^a Pressure relating to maximum cylinder filling pressure at 15 °C.

^b General recommendation: Flow rates more than 0,8 m³/h should be avoided due to limitations in the allowable average gas withdrawal rate from one acetylene cylinder.

^c Vapour pressure for MPS at 65 °C. This value may change depending on the components of the gas mixture.

^d Vapour pressure for propane at 70 °C.

^e Depending upon ambient conditions, the use of a heater may be necessary to achieve standard discharge with LPG and CO₂ gases.

^f Pressure for CO₂ at 70 °C at the filling ratio of 0,667.

6.4 Pressure-relief valve

6.4.1 General

The leakage of the pressure-relief valve shall comply with the requirements of 5.2.10 up to the maximum closing pressure p_4 .

The minimum discharge Q_{RV} of the pressure-relief valve, if fitted, shall be equal to or greater than the standard discharge Q_1 or nominal flow Q_n (see Table 1) for a pressure p_{RV} defined by the expression $p_{RV} = 2 \times p_2$ or $2 \times p_{2m}$ (see Table 1), except in the case of acetylene pressure regulators, where p_{RV} shall be equal to 3 bar for all classes.

With decreasing pressure, the relief valve shall close at a pressure greater than p_2 or p_{2m} . The relief valve shall be non-adjustable by the user.

The relief valve should be fitted in such a way that gas will be discharged safely.

The relief valve shall comply with the test in 9.7.5.

6.4.2 Relief valve for acetylene

The leakage of the relief valve shall comply with the requirements of 5.2.10 up to the maximum closing pressure of 1,5 bar.

6.5 Operating-temperature range

The pressure regulators shall be capable of operating normally in the temperature range -20 °C to $+60\text{ °C}$.

6.6 Performance and operating characteristics

6.6.1 Pressure regulators without flow-metering devices

6.6.1.1 Coefficient of pressure increase upon closure R

The coefficient is defined by:

$$R = \frac{p_4 - p_2}{p_2} \quad (2)$$

[For acetylene pressure regulators of class 2, $p_2 = p_{2R}$, as shown in Figure 1b) and defined in 9.5.3.3.]

where p_4 is the closing outlet pressure noted 1 min after stopping the standard discharge (Q_1 , p_2 , p_3). For acetylene pressure regulators of class 2, the initial conditions are Q_1 , p_{2R} for inlet pressure p_3 .

For standard discharge Q_1 , the coefficient R of pressure increase upon closure shall be less than 0,3.

6.6.1.2 Irregularity coefficient i

The coefficient:

$$i = \frac{p_5 - p_2}{p_2} \quad (3)$$

shall be within the limits: $-0,3 < i < +0,3$

where p_5 is the highest or lowest value of the outlet pressure (see Figure 2) during a test in which the inlet pressure varies from p_1 to p_3 for a flow equal to the standard discharge Q_1 in accordance with Table 1 or as specified by the manufacturer.

For acetylene pressure regulators of class 2, $p_2 = p_{2i}$, as defined in 9.5.5.3.

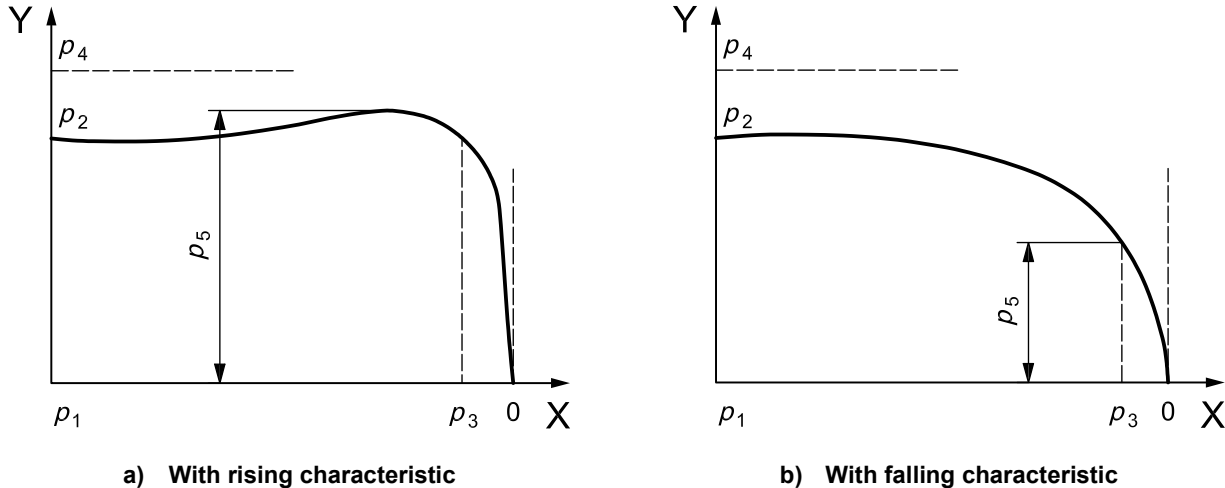

Key

- X inlet pressure
- Y outlet pressure

Figure 2 — Typical dynamic expansion curves

6.6.2 Pressure regulators with flow-metering devices

6.6.2.1 Accuracy classification

The error in the flow indication shall remain within the limits defined by the classification indicated in Table 4 or ± 1 l/min, whichever is greater.

Table 4 — Accuracy classification

Accuracy class	10	20
Maximum error of the flow indication	$\pm 10 \%$	$\pm 20 \%$

For any indicated flow between Q_n and 30 % of Q_n , or for any fixed orifice, the error in flow indication shall not exceed that of the respective accuracy class in Table 4.

Pressure regulators with flow-metering devices shall comply with the test in 9.6.1.

EXAMPLE 1 For a pressure regulator with a flow-metering device of class 10 and $Q_n = 40$ l/min, the allowed true flow at Q_n is (40 ± 4) l/min:

- at $Q = 12$ l/min (30 % of Q_n), the allowed true flow is $(12 \pm 1,2)$ l/min;
- at $Q = 26$ l/min (65 % of Q_n), the allowed true flow is $(26 \pm 2,6)$ l/min.

EXAMPLE 2 For a pressure regulator with a flow-metering device with fixed orifices of class 10 and flows of 10 l/min, 20 l/min, 30 l/min and 40 l/min, the allowed true flows are respectively $(10,00 \pm 1)$ l/min, $(20,00 \pm 2)$ l/min, $(30,00 \pm 3)$ l/min and $(40,00 \pm 4)$ l/min.

6.6.2.2 Stability of the flow

For an initial setting of Q_n at an inlet pressure of p_1 , the change in true flow, as measured with a calibrated measuring apparatus, shall be within $\pm 30\%$ at any inlet pressure between p_1 and p_3 .

For pressure regulators with a flow-metering device with multiple calibrated orifices, the stability requirement shall be fulfilled by the orifice allowing the highest flow.

Pressure regulators with a flow-metering device shall comply with the test in 9.6.2.

7 Marking

7.1 Pressure regulators without flow-metering devices

The following information shall be clearly and permanently marked in accordance with 9.8 on the pressure-regulator body or cover or on a label permanently fixed to the pressure regulator:

- the number of this International Standard;
- the name or trademark of the manufacturer and/or distributor;
- the pressure-regulator class or p_2 and Q_1 in accordance with 6.3;
- the nominal inlet pressure, p_1 , nominated by the manufacturer (only for oxygen and other compressed gases);
- the gas intended for use: when the full name of the gas cannot be imprinted, the code letters used in Table 5 should be used.

Table 5 — Code letter for gases to be used for marking of pressure regulators

Type of gas	Code letter
Acetylene	A
Oxygen	O
Hydrogen	H
Compressed air	D or Air
LPG (includes propane, butane and propylene)	P
MPS	Y
Natural gas	M
CO ₂ , nitrogen, inert gas	N

7.2 Pressure regulators with flow-metering devices

The following information shall be clearly and permanently marked in accordance with 9.8 on the pressure-regulator body or cover, or on a label permanently fixed to the pressure regulator with a flow-metering device:

- the number of this International Standard;
- the name or trademark of the manufacturer and/or distributor;
- the designation of the model of the pressure regulator with a flow-metering device;

- the accuracy class;
- the nominal discharge Q_n or the flow range;
- the nominal inlet pressure, p_1 ;
- the gas (or range of gas mixtures) intended for use or its specific mass (or range of specific masses).

8 Instructions for use

The manufacturer, supplier or distributor shall supply instructions for use with each pressure regulator, and with each pressure regulator with a flow-metering device, covering at least:

- a) the field of application of the pressure regulator; or
- b) the field of application of the pressure regulator with a flow-metering device; in particular the range of specific gravity of the gases or gas mixtures for which it can be used;

EXAMPLE Flow meter which can be used for mixtures ranging from an argon-carbon dioxide mixture (specific gravity: 1,69) up to an argon-hydrogen mixture (specific mass: 1,57).

- c) a description of the pressure regulator, or of the pressure regulator with a flow-metering device and the meaning of the marking;
- d) the safe and correct installation of the pressure regulator, or of the pressure regulator with a flow-metering device;
- e) the commissioning tests that are necessary to prove safe and correct installation prior to service;
- f) the use and maintenance of the pressure regulator, or of the pressure regulator with a flow-metering device (intended for the operator);
- g) hazards and safety precautions in the case of oxygen.

9 Type-test procedure

9.1 General

Checking conformity to this International Standard of a pressure regulator, or a pressure regulator with a flow-metering device of a given type, consists of

- tests, and
- checking of documents.

Conformity to the requirements of the present International Standard can be confirmed by an independent body.

The oxygen ignition test (see 9.7.4) shall be carried out after the tests for performance and operating characteristics (see 6.6.1 and 6.6.2) and before the resistance test to internal pressure (see 9.7.2.1).

NOTE These are type tests applicable to pressure regulators only for verifying conformity to this International Standard and are not intended as a programme for production testing of all pressure regulators.

9.2 Test samples and necessary documents

For the tests, the following samples and documents shall be available:

- three samples of the pressure regulator without and with a flow-metering device (five samples in the case of oxygen);
- one set of general-arrangement drawings with material lists;
- two sets of detail drawings;
- if necessary, a declaration from the manufacturer giving the material specifications and fitness for purpose.

The tests shall be carried out with pressure regulators, and with pressure regulators with flow-metering devices, which are in accordance with the drawings.

9.3 Test conditions

9.3.1 General characteristics of the test installation

All the pipelines of the test installation, together with the valve controlling the flow, shall have a flow capacity greater than that of the pressure regulator to be tested.

9.3.2 Test gas

Tests shall be carried out with air or nitrogen, free from oil and grease.

The ignition test in accordance with 9.7.4 shall be carried out with oxygen.

In all cases, tests shall be carried out with a gas with a maximum moisture content of 50 µg/g (50 parts per million) corresponding to a dew-point of -40 °C.

9.3.3 Accuracy of the flow-measuring apparatus

The accuracy of the flow-measuring apparatus shall not exceed ± 3 % of the measuring range.

9.3.4 Pressure measurement

The test bench shall be constructed in such a way that upstream and downstream pressures can be regulated. The equipment may be operated by remote control.

The source of gas for the nominal inlet pressures p_1 and p_3 shall have gas available for the duration of the test.

Pressure gauges shall not exceed a 1 % error of their indication.

9.4 Units

9.4.1 Pressure

The pressures measured are gauge pressures ³⁾ and are expressed in bars or MPa.

3) Pressure exceeding atmospheric pressure.

9.4.2 Flow

Flow rates are measured in cubic metres per hour (m³/h) or in litres per minute (l/min) under normal conditions ⁴⁾ taking into account the relevant conversion coefficient for the gas used (see Table 6).

Table 6 — Conversion coefficient, *U*

Test gas	Conversion coefficient								
	Air	Oxygen	Nitrogen	Argon	Hydrogen	Helium	Acetylene	LPG, e.g. propane	CO ₂
Air	1	0,950	1,02	0,851	3,81	2,695	1,05	0,800	0,808
Nitrogen	0,983	0,930	1	0,837	3,75	2,65	1,03	0,784	0,792

The conversion coefficient, *U*, is based on the formula:

$$U = \sqrt{\frac{\gamma_0}{\gamma_1}} \tag{4}$$

where

γ_0 is the specific gravity of the test gas;

γ_1 is the specific gravity of the gas used.

9.4.3 Temperature

Temperatures are measured in degrees Celsius.

9.5 Test for performance and operating characteristics of pressure regulators without flow-metering devices

9.5.1 General

An example of the test apparatus used for the measurement of the maximum discharge, Q_{max} , is shown in Figure 3. The pressure regulator may, for example, be supplied by a buffer cylinder. The upstream pressure p_3 (see 6.2.1) is kept constant by means of an auxiliary pressure regulator or any equivalent device.

4) Normal conditions are 23 °C and 1,013 bar (0,101 3 MPa) (in accordance with ISO 554).

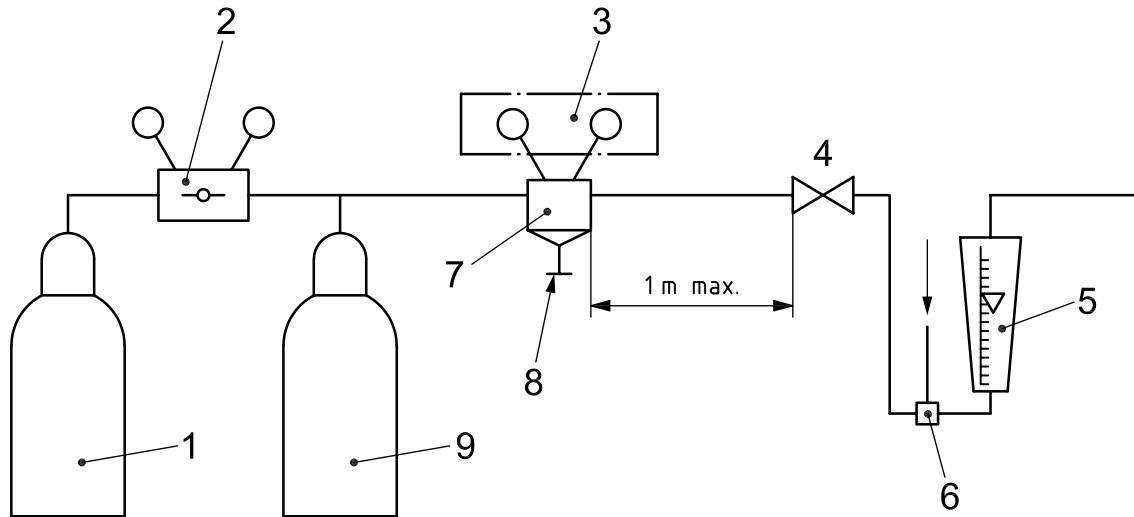
**Key**

- | | |
|--------------------------------|--|
| 1 gas supply | 6 thermometer for measurement of gas temperature |
| 2 auxiliary pressure regulator | 7 pressure regulator (test sample) |
| 3 calibrated gauges | 8 adjusting screw |
| 4 control valve for regulation | 9 buffer cylinder |
| 5 flow meter | |

Figure 3 — Example for the measurement of the maximum discharge Q_{\max}

9.5.2 Maximum discharge Q_{\max}

9.5.2.1 General

The maximum discharge, Q_{\max} , shall be measured at an inlet pressure p_3 according to 9.5.2.2. and 9.5.2.3.

9.5.2.2 Maximum discharge, Q_{\max} , excluding acetylene regulators of class 2

The adjusting screw of the pressure-regulator sample under test shall be fully screwed in, and the valve for regulation shall be opened so that

- the downstream pressure gauge indicates the nominal outlet pressure p_2 , and
- the flow meter indicates the maximum discharge, Q_{\max} , taking into account the corrections in 5.2 and Table 6, and the temperature measured by the thermometer.

9.5.2.3 Maximum discharge, Q_{\max} , for acetylene pressure regulators of class 2

The adjusting screw of the pressure-regulator sample under test shall be fully screwed in, and the valve for regulation shall be fully opened. The flow meter indicates the maximum discharge, Q_{\max} [see Figure 1b)], taking into account the corrections in 9.4.2 and Table 6, and the temperature measured by the thermometer.

9.5.3 Standard discharge Q_1

9.5.3.1 General

The standard discharge, Q_1 , shall be obtained using the settings in 9.5.3.2 and 9.5.3.3.

9.5.3.2 Standard discharge, Q_1 , excluding acetylene pressure regulators of class 2

The adjusting screw of the pressure-regulator sample under test and the valve for regulation shall be set to achieve an outlet pressure, p_2 , and Q_1 at an inlet pressure p_3 .

9.5.3.3 Standard discharge, Q_1 , for acetylene pressure regulators of class 2

The adjusting screw of the pressure-regulator sample under test shall be fully screwed in, and the valve for regulation shall be opened to achieve Q_1 at an inlet pressure p_3 and the corresponding outlet pressure shall be measured. This pressure shall be referred to as p_{2R} [see Figure 1b)].

9.5.4 Coefficient of pressure increase upon closure, R

With the pressure regulator set to standard discharge conditions (see 9.5.3), proceed as follows:

- stop the flow by using the valve for regulation;
- after 1 min, record the stabilization pressure p_4 ;
- determine the value of R (see 6.6.1.1).

9.5.5 Irregularity coefficient, i

9.5.5.1 General

For the determination of the irregularity coefficient, i , (see 6.6.1.2) a dynamic expansion curve is plotted. This curve indicates the downstream pressure as a function of the upstream pressure. During this test, the upstream pressure varies from the nominal inlet pressure p_1 to the inlet pressure p_3 .

An example of the test apparatus is shown in Figure 4.

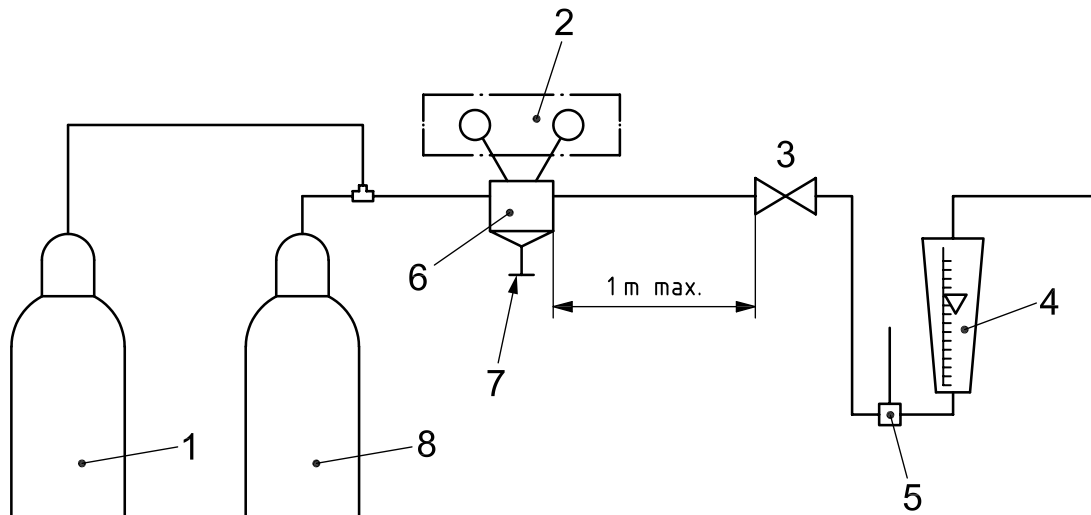

Key

- | | |
|-----------------------------------|--|
| 1 auxiliary gas cylinder | 5 thermometer for measurement of gas temperature |
| 2 gauges, see 9.3.4 or equivalent | 6 pressure regulator (test sample) |
| 3 control valve for regulation | 7 adjusting screw |
| 4 flow meter | 8 primary gas cylinder |

Figure 4 — Example of test apparatus for the measurement of the dynamic expansion curves

The pressure regulator is equipped with two pressure gauges in accordance with 9.3.4, preferably recording gauges ⁵⁾. The pressure regulator is supplied from a source of gas capable of being adjusted in a smooth and continuous way at an approximately constant rate, e.g. by one or more gas cylinders. The source of gas shall be capable of supplying the test gas at the nominal inlet pressure p_1 . The pressure-regulator discharge is controlled by a flow meter.

9.5.5.2 Pre-test settings excluding acetylene pressure regulators of class 2

The adjusting screw of the pressure-regulator sample under test and the valve for regulation shall be set to achieve an outlet pressure, p_2 , and a standard discharge, Q_1 at an inlet pressure p_1 .

9.5.5.3 Pre-test settings for acetylene pressure regulators of class 2

The adjusting screw of the pressure-regulator sample under test shall be fully screwed in and the valve for regulation shall be adjusted to achieve a standard discharge, Q_1 , at an inlet pressure p_1 . The resulting outlet pressure shall be measured and referred to as p_{2i} .

9.5.5.4 Tests

Without changing the preceding setting of the test pressure regulator, an inlet pressure p_1 shall be applied. The inlet pressure shall then be continuously and smoothly decreased, e.g. by allowing a gas-cylinder to be fully discharged. At this time, the values of the upstream and downstream pressures are recorded. The test period shall be at least 15 min and a maximum period of 30 s is allowed for the pre-test settings, if necessary.

9.5.5.5 Results

During this test, there shall be no evidence of oscillation or sticking of the pressure-regulating valve of the pressure regulator, and there shall be a smooth pressure-regulator dynamic expansion curve, which will either rise to a maximum [see Figure 2a)] or fall [see Figure 2b)].

The pressure p_5 for the determination of the irregularity coefficient i , is the highest or lowest value of the outlet pressure during this test in which the inlet pressure varies from p_1 to p_3 .

Determine the value of i (see 6.6.1.2).

9.6 Test for performance and operating characteristics of pressure regulators with flow-metering devices

9.6.1 Test for accuracy classification

Connect the outlet of the pressure regulator with a flow-metering device to be tested to the flow-measuring apparatus.

With an inlet pressure of p_1 , set the initial flow at Q_n or, for multiple calibrated orifices, select the orifice with the highest flow. Without modifying this setting, the inlet pressure shall then be decreased from p_1 to p_3 .

Record both the indicated flow of the measuring device of the pressure regulator with a flow-metering device and the true flow on at least five different pressures along the decreasing pressure curve (see Figure 5).

The difference between the indicated flow and the true flow, as a percentage of the indicated flow, shall be recorded.

Repeat the above-mentioned test for 30 % of Q_n and 65 % of Q_n . Perform the above tests for all other fixed orifices.

5) Or any other recording device which produces the dynamic expansion curve directly.

An example of the test apparatus used for the measurement of the flow is shown in Figure 6.

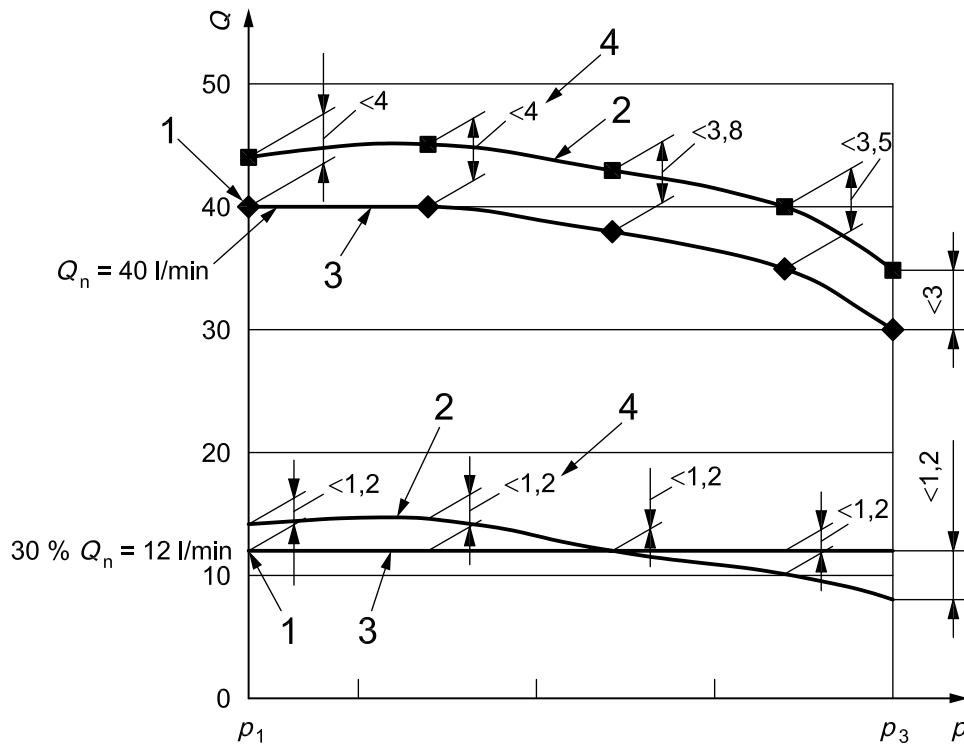

Key

- 1 initial setting
- 2 true flow as measured by a calibrated measuring apparatus
- 3 indicated flow
- 4 permissible error of the flow indication

Figure 5 — Example of a test for accuracy classification (pressure regulator with flow-metering devices of class 10)

9.6.2 Test for stability of the flow

Connect the outlet of the pressure regulator with a flow-metering device to be tested to the flow-measuring apparatus.

Set the initial flow at Q_n or, for multiple fixed orifices, select the orifice with the highest flow, at an inlet pressure p_1 . Without modifying this setting, the inlet pressure shall then be decreased from p_1 to p_3 .

Record the true flow on at least five different pressures along the decreasing pressure curve (see Figure 7).

The change in true flow, as a percentage of the true flow measured at the initial setting, shall be recorded.

An example of the test apparatus used for the measurement of the stability of the flow is shown in Figure 6.

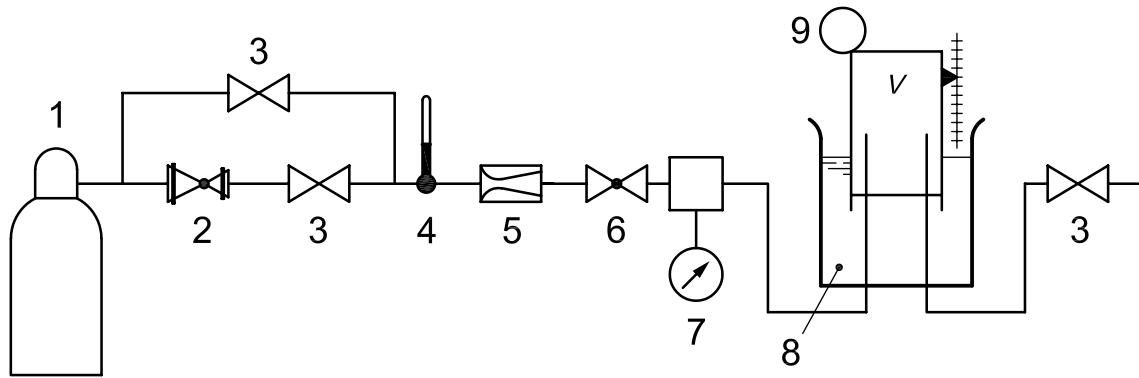

Key

- | | |
|---|---|
| 1 gas-supply source | 6 control valve for flow regulation |
| 2 pressure regulator ensuring a stabilized pressure during the test | 7 pressure gauge or equivalent pressure sensor inlet with 1 % maximum permissible error |
| 3 shut-off valve | 8 container with water |
| 4 thermometer | 9 calibrated vial containing the test gas |
| 5 pressure regulator with a flow-metering device (test sample) | V gas volume to be measured |

Figure 6 — Example of test apparatus

In the example of the test apparatus in Figure 6, the increase of the gas volume V contained in the calibrated vial for a certain duration (30 s, 1 min or more), adjusted for its eventual pressure variation (measured by the water level differential or the calibrated pressure gauge) and under standard conditions, determines the true value of the flow, expressed in l/min, through the tested equipment (an example is given in Figure 7).

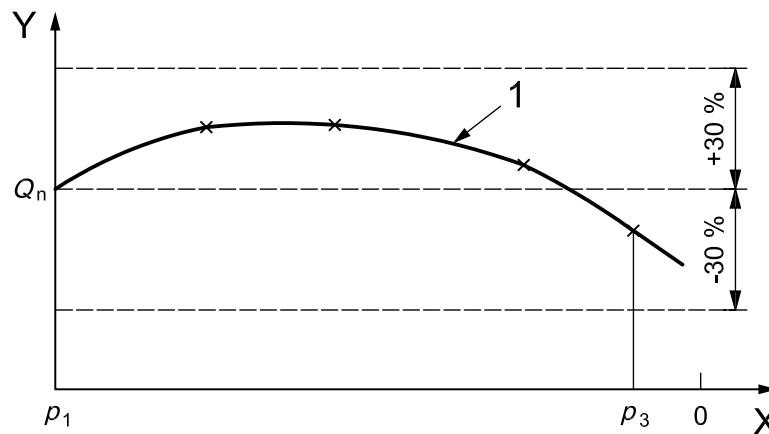

Key

- X inlet pressure
- Y flow rate
- 1 true flow from an initial setting at Q_n and p_1

Figure 7 — Example of test for stability of flow

9.7 Tests for mechanical resistance of pressure regulators or pressure regulators with a flow-metering device

9.7.1 General

WARNING — Precautions shall be taken to protect test personnel.

9.7.2 Test for mechanical resistance to internal pressure

9.7.2.1 Resistance test to internal pressure

For this test (see 5.2.11.1), the relief valve, diaphragm, pressure gauges and flow-metering devices shall be replaced by blind plugs. The low and high-pressure chambers shall be hydraulically pressurized for 5 min. After the test, check that there is no permanent deformation (for example, measured by comparison).

The test pressures are given in Table 2.

9.7.2.2 Pressure retention test of the low-pressure side of the pressure regulator

For this test (see 5.2.11.2), the pressure-regulator valve shall be held permanently open. The pressure gauges and flow adjusting and measuring devices shall be replaced by blind plugs and the outlet connection blanked off.

A pneumatic pressure p_1 shall be applied to the pressure-regulator inlet, through a valve which is manually opened quickly.

If no rupture occurs, the test is satisfactory.

If rupture occurs, no pieces shall be ejected. Venting of gas through pressure-relief devices, if fitted, is allowed.

9.7.3 Leakage tests

9.7.3.1 External leakage

Gas tightness to the atmosphere shall be tested in accordance with ISO 9090.

An example of the test apparatus used for the external leakage test is shown in Figure 8.

9.7.3.2 Internal leakage

Gas tightness of the pressure-regulator valve assembly:

- a) The internal gas tightness of the pressure-regulator valve seat is tested at the nominal inlet pressure p_1 for 5 min. For adjustable pressure regulators, the regulator valve shall be closed (pressure-adjusting screw completely unscrewed) and the outlet shall be open. An escape of gas of 0,2 mbar l/min (12 cm³/h) is allowed. This test does not apply to preset regulators.
- b) The internal gas tightness of the pressure-regulator valve is also tested with the outlet closed and the pressure in the low-pressure chamber is adjusted to the value p_2 with the pressure-adjusting screw. This test applies to adjustable and preset pressure regulators. The value p_2 shall be constant during the test period of 5 min.

Tests a) and b) shall be repeated at an inlet pressure p_3 .

9.7.4 Ignition test for pressure regulators and pressure regulators with flow-metering devices for oxygen

Three samples of the oxygen pressure regulator, or pressure regulator with a flow-metering device shall be exposed, through their inlets, to pressure shocks from industrial oxygen (minimum 99,5 % purity; hydrocarbons less than or equal to 10 parts per million). The test system (see Figure 9) shall be provided with equipment for preheating the oxygen, an oxygen vessel and a quick-opening valve. Figure 9 gives an example of a test bench.

Dimensions in millimetres

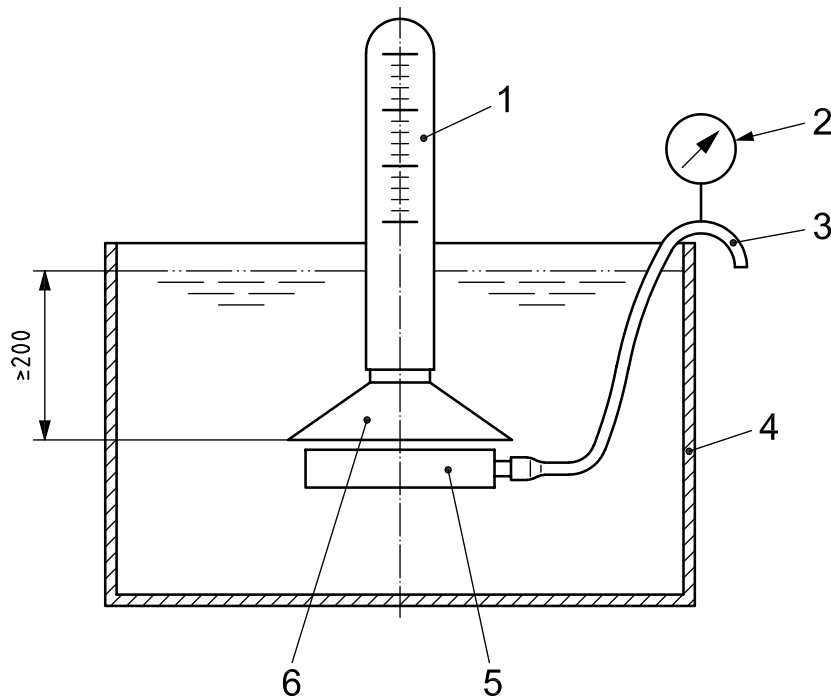

Key

- | | |
|-----------------------|------------------------------------|
| 1 cylinder with scale | 4 water tank |
| 2 calibrated gauge | 5 pressure regulator (test sample) |
| 3 gas supply | 6 funnel |

Figure 8 — Example of test apparatus for the external leakage test

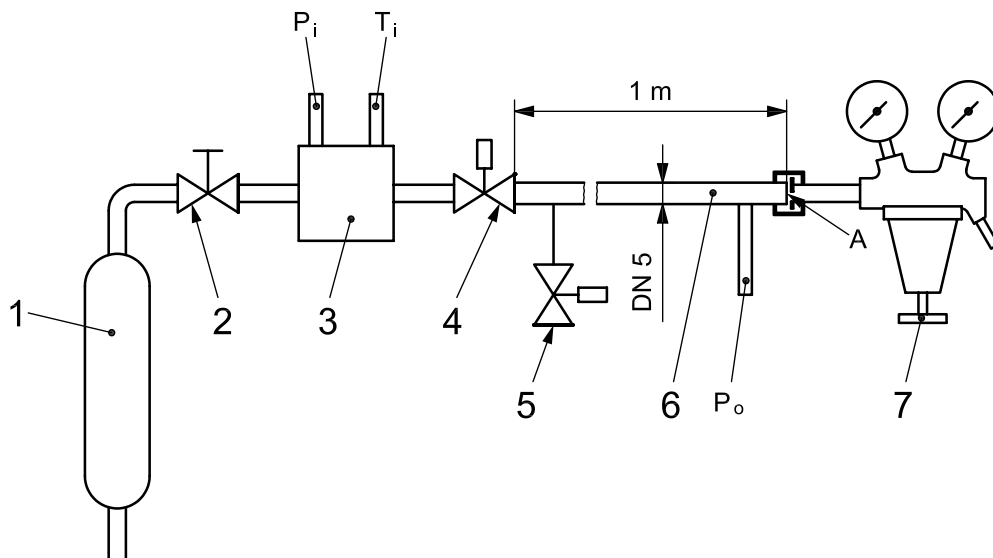

Key

- | | |
|--|--|
| 1 oxygen supply | 6 connecting tube |
| 2 inlet valve | 7 pressure regulator (test sample) |
| 3 high-pressure oxygen vessel with preheating device (e.g. water bath, electric heating) | P_i pressure transducer on the oxygen vessel |
| 4 quick opening valve | P_o pressure transducer on the outlet valve |
| 5 valve to decrease the outlet pressure after every shock | T_i thermo-element |
| | A measuring point |

Figure 9 — Example of test bench for ignition test

The time required to increase the pressure from atmospheric up to the test pressure shall be (20_{-5}^0) ms, measured at point A prior to the test (see Figure 9).

The pressure shall also be measured at a distance of 30 mm to 40 mm from the sealing face of the sample (p_o , see Figure 9). At least every second pressure shock shall be recorded. The connection tube between the quick-opening valve and the pressure regulator under test shall be 1 000 mm in length and 5 mm in internal diameter, made from oxygen-resistant metallic material, for example, copper, stainless steel or brass. The specified dimensions of the tube are essential, in order to ensure that a well-defined energy input into the pressure regulator to be tested is achieved. Before starting the test, the test samples shall be at room temperature. The test pressure shall, in all cases, be $1,2 \times p_1$ at a temperature of $(60 \pm 3) \text{ }^\circ\text{C}$

Each test series shall consist of 20 pressure shocks at intervals of 30 s (see Figure 10). The sample shall be at room temperature at the start of each sequence.

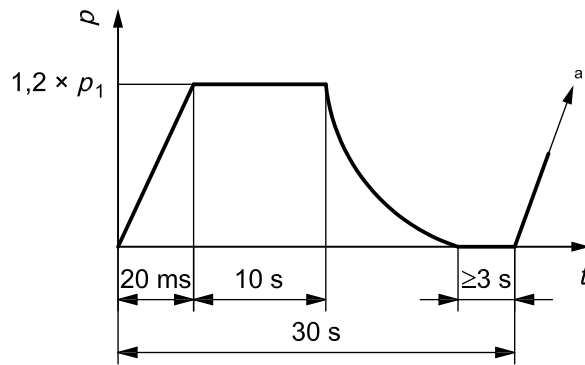

Key

- p pressure
- t time
- p_1 inlet pressure
- a Next pressure shock

Figure 10 — Test interval

Each pressure shock is applied for 10 s. After each pressure shock, the pressure regulator is brought back to atmospheric pressure. This shall not be done by adjusting the pressure regulator, but by operating an upstream outlet valve. Between each pressure shock, the atmospheric pressure shall be held for at least 3 s.

During a test series, the inlet pressure shall not decrease by more than 3 %.

The tests shall be carried out under the following conditions:

- a) for adjustable and preset pressure regulators, with the pressure-regulator valve in the fully opened position and with the outlet closed;
- b) for adjustable pressure regulators only, with the pressure-regulator valve in the fully closed position.

The pressure regulator shall not burn out during the test. After the tests have been completed, the three test samples shall be dismantled and all internal parts and surfaces inspected. Internal damage and evidence of burning are not acceptable.

9.7.5 Test method for pressure-relief valve

9.7.5.1 Pressure-relief valve tightness test

Verify that, at all pressures, the relief valve remains leaktight in accordance with 6.4 when the flow is stopped by having the adjusting pressure device totally screwed in. The test is to be performed at least at the inlet

pressures p_1 and p_3 , by applying the closing pressure p_4 as defined in 6.6.1.1 and at the inlet pressure corresponding to p_5 as defined in 6.6.1.2, if p_5 is greater than p_2 .

9.7.5.2 Pressure-relief valve performance test

For this test, the pressure-regulator valve shall be fully opened or removed. The outlet of the pressure regulator shall be blanked off. An increasing pressure is applied through the inlet up to the pressure given in 6.4. At this pressure, the relief valve shall be leaktight.

The pressure shall then be increased up to the opening pressure of the relief valve, which shall be noted. The pressure shall be increased up to the pressure p_{RV} as defined in 6.4.1 and measured in the low-pressure chamber. At this pressure, the discharge Q_{RV} of the pressure-relief valve shall be measured (see 6.4). The pressure shall be decreased and the closing pressure of the relief valve shall be noted (see 6.4).

9.8 Test for durability of markings

Markings shall be rubbed by hand, without undue pressure, first for 15 s with a cloth soaked with distilled water, then for 15 s with a cloth soaked with petroleum spirit. Labels, if used as markings, shall be adhesive over the whole attachment surface.

After the test, the marking shall remain legible.

Annex A (informative)

Pressure regulators

A.1 Example of a pressure regulator without a flow-metering device

Table A.1 gives the meanings of the reference numbers in Figure A.1.

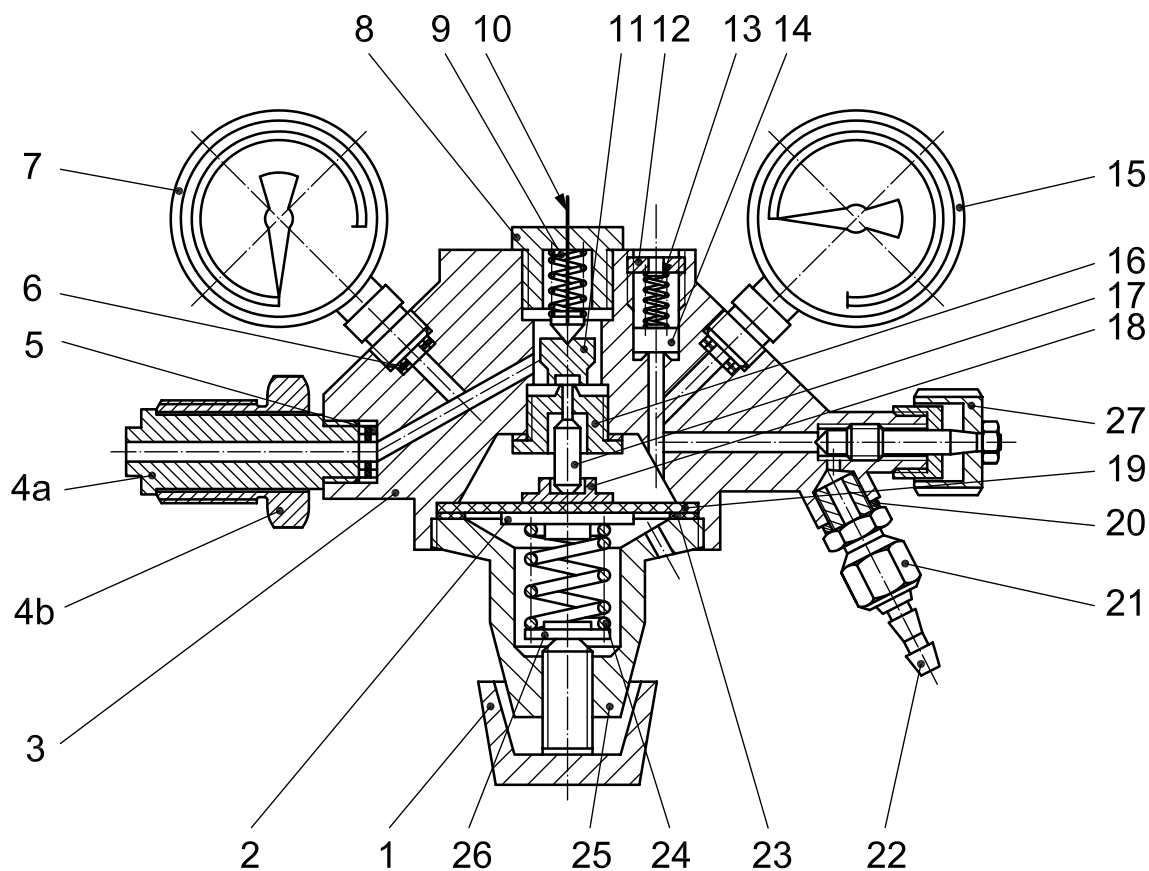

NOTE 1 Parts 12, 13 and 14 are components of the relief valve.

NOTE 2 Part 27 is an outlet shut-off valve and its installation is optional, see 5.2.5.

NOTE 3 Parts 4a and 4b of the drawing are examples and are not specified. Other types of inlet connection pieces are also in use.

Figure A.1 — Diagram of a typical pressure regulator

Table A.1 — List of terms

No.	English	French	German
1	pressure-adjusting screw	vis de réglage	Einstellschraube
2	spring plate	plateau de membrane	Federteller
3	body	corps	Körper
4a	inlet stem	raccord d'entrée	Eingangsstutzen
4b	inlet nut	écrou flottant raccord d'entrée	Schraubverbindung
5	inlet filter	filtre d'entrée	Eintrittsfilter
6	gauge sealing	joint de manomètre	Manometerdichtung
7	high-pressure gauge	manomètre haute pression (amont)	Hochdruckmanometer
8	pressure-regulator-valve cap	bouchon de clapet	Verschlusschraube
9	pressure-regulator-valve spring	ressort de clapet	Regelventilfeder
10	spring plate	appui mobile de centrage du ressort de clapet	Regelventil-Federteller
11	pressure-regulator valve	clapet	Regelventil
12	relief-valve cap	vis de réglage de la soupape de sécurité	Einstellschraube des Abblaseventils
13	relief-valve spring	ressort de soupape de sécurité	Abblaseventilfeder
14	relief-valve seat	clapet de soupape de sécurité	Abblaseventilsitz
15	low-pressure gauge	manomètre basse pression (aval)	Niederdruckmanometer
16	pressure-regulator-valve seat	siège	Regelventilsitz
17	pressure-regulator-valve pin	poussoir	Regelventilstift
18	diaphragm plate	plateau d'appui du poussoir	Membranteller
19	diaphragm	membrane	Membran
20	outlet-connection piece	raccord de sortie (mamelon fileté)	Abgangsstutzen
21	union nut	écrou de douille	Überwurfmutter
22	hose tail	douille porte-tuyau	Schlauchtülle
23	diaphragm seal	joint de membrane	Membrangleitring
24	pressure-regulator spring	ressort de détente	Stellfeder
25	pressure-regulator cover	couvercle	Federdeckel
26	pressure-regulator-spring plate	appui mobile de centrage du ressort de détente	Stellfederteller
27	outlet valve	robinet de sortie	Absperrventil

A.2 Examples of typical pressure regulators with flow-metering devices

Table A.2 gives the meanings of the reference numbers in Figure A.2.

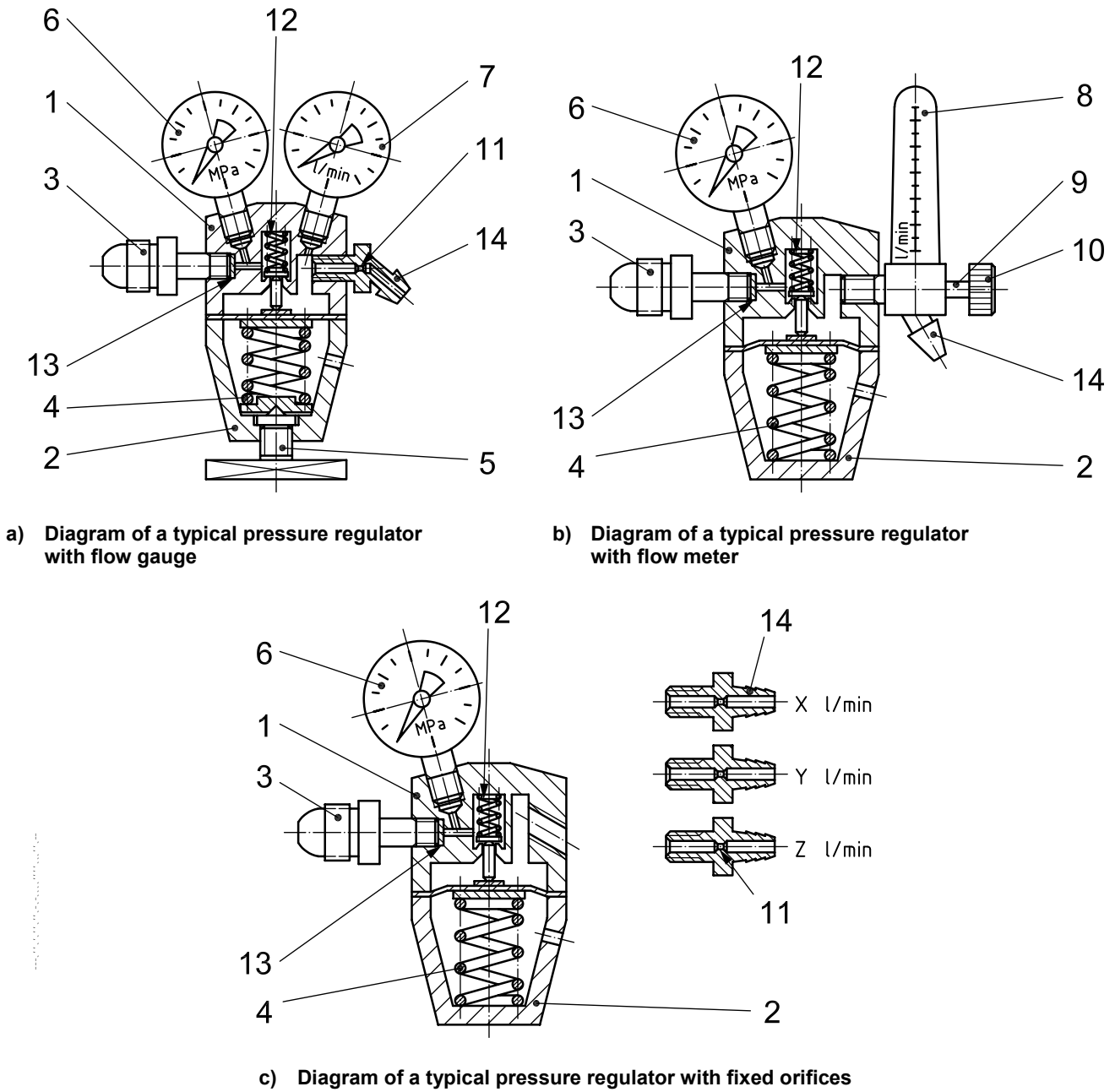

Figure A.2 — Typical pressure regulators

Table A.2 — List of terms

No.	English	French	German
1	body	corps	Körper
2	pressure-regulator cover	couvercle	Federdeckel
3	inlet connector	raccord d'entrée	Eingangsanschluss
4	pressure-regulator spring	ressort de détente	Stellfeder
5	pressure-adjusting screw	vis de réglage	Einstellschraube
6	high-pressure gauge	manomètre haute pression (amont)	Hochdruckmanometer
7	flow gauge	indicateur de débit	Durchflussmanometer
8	flow meter	débitmètre	Durchflussmesser (Flow meter)
9	flow-control-valve spindle	tige de commande du débit	Spindel des Dosierventils
10	flow-control-valve knob	volant de réglage du débit	Durchflusseinstellhandrad
11	fixed orifice	orifice fixe	Feste Blende
12	pressure-regulator valve	clapet	Regelventil
13	inlet filter	filtre d'entrée	Eintrittsfilter
14	outlet-connection piece	raccord de sortie (mamelon fileté)	Abgangsstützen

Annex B (informative)

Operating principles of pressure regulators with flow-metering devices

Pressure regulators with flow-metering devices can be distinguished by their flow control and flow-measuring system.

Three principles of flow-control systems are possible:

- a variable orifice through which the gas passes, with a constant upstream pressure p_{2m} , e.g. a pressure regulator with a flow meter [see Figure A.2b)], or
- a fixed orifice through which the gas passes, with a variable upstream pressure p_{2m} , e.g. a pressure regulator with a flow gauge [see Figure A.2a)], or
- a fixed orifice through which the gas passes, with a constant upstream pressure p_{2m} , e.g. a pressure regulator with fixed orifices [see Figure A.2c)].

NOTE A combination of these principles is possible.

A flow adjustment of these systems may be either progressive or in fixed steps.

Table B.1 gives examples of some systems.

Table B.1 — Examples of flow-control systems coupled with their flow-measuring devices

Variable orifice and constant upstream pressure	
<p>This system comprises a vertical transparent tube, the cross-section of which increases upwards, in which a float is lifted by the action of the gas flow. The float settles at a height which is a function of the flow value.</p>	
<p>This system comprises a paddle connected to a return spring and is situated at the outlet of a calibrated gas-supply orifice. The paddle is pushed by the action of the gas flow and settles at a position which is a function of the flow value.</p>	
Fixed orifice and constant upstream pressure	
<p>This system comprises only a calibrated orifice to control the flow. There is no indication of the upstream pressure or of the flow passing through the system.</p>	
Fixed orifice and variable upstream pressure	
<p>This system comprises a pressure gauge measuring the gas pressure immediately upstream of a calibrated orifice. The pressure measured is a function of the flow value.</p>	
<p>This system comprises a differential pressure gauge measuring the pressure drop across a calibrated orifice. This pressure drop is a function of the flow value.</p>	

Bibliography

- [1] ISO 7291, *Gas welding equipment — Pressure regulators for manifold systems used in welding, cutting and allied processes up to 30 MPa (300 bar)*
- [2] ISO/TR 28821, *Gas welding equipment — Hose connections for equipment for welding, cutting and allied processes — Listing of connections which are either standardised or in common use*

© ISO 2009

.....

.....

ICS 25.160.30

Price based on 30 pages