**Paints and varnishes — Determination of
flow time by use of flow cups**

*Peintures et vernis — Détermination du temps d'écoulement au moyen
de coupes d'écoulement*



Reference number
ISO 2431:2011(E)

© ISO 2011



COPYRIGHT PROTECTED DOCUMENT

© ISO 2011

All rights reserved. Unless otherwise specified, no part of this publication may be reproduced or utilized in any form or by any means, electronic or mechanical, including photocopying and microfilm, without permission in writing from either ISO at the address below or ISO's member body in the country of the requester.

ISO copyright office
Case postale 56 • CH-1211 Geneva 20
Tel. + 41 22 749 01 11
Fax + 41 22 749 09 47
E-mail copyright@iso.org
Web www.iso.org

Published in Switzerland

Contents

Page

Foreword	iv
Introduction	v
1 Scope	1
2 Normative references	1
3 Terms and definitions	1
4 Temperature considerations	2
5 Apparatus	2
5.1 Flow cups	2
5.2 Supplementary apparatus	5
6 Sampling	6
7 Procedure	6
7.1 Preliminary check for Newtonian flow	6
7.2 Determination of flow time	6
8 Marking of products tested	7
9 Precision	7
9.1 General	7
9.2 Repeatability limit r	8
9.3 Reproducibility limit R	8
10 Test report	8
Annex A (normative) Checking flow cups for wear and tear	10
Annex B (informative) Conversion of flow times from one temperature to another	12
Bibliography	15

Foreword

ISO (the International Organization for Standardization) is a worldwide federation of national standards bodies (ISO member bodies). The work of preparing International Standards is normally carried out through ISO technical committees. Each member body interested in a subject for which a technical committee has been established has the right to be represented on that committee. International organizations, governmental and non-governmental, in liaison with ISO, also take part in the work. ISO collaborates closely with the International Electrotechnical Commission (IEC) on all matters of electrotechnical standardization.

International Standards are drafted in accordance with the rules given in the ISO/IEC Directives, Part 2.

The main task of technical committees is to prepare International Standards. Draft International Standards adopted by the technical committees are circulated to the member bodies for voting. Publication as an International Standard requires approval by at least 75 % of the member bodies casting a vote.

Attention is drawn to the possibility that some of the elements of this document may be the subject of patent rights. ISO shall not be held responsible for identifying any or all such patent rights.

ISO 2431 was prepared by Technical Committee ISO/TC 35, *Paints and varnishes*, Subcommittee SC 9, *General test methods for paints and varnishes*.

This fifth edition cancels and replaces the fourth edition (ISO 2431:1993), which has been technically revised. It also incorporates the Technical Corrigenda ISO 2431:1993/Cor.1:1994 and ISO 2431:1993/Cor.2:1999.

The main technical changes are as follows:

- a) the curves in Figures 2 to 5 have been placed in a single figure (Figure 2) and the equations for the conversion of flow time to kinematic viscosity and *vice versa* represented by the curves in these figures have been moved from the figures to a table (Table 1);
- b) the accuracy of the stopwatch used is no longer specified;
- c) a clause has been added describing the marking of products tested to indicate the results of the test;
- d) the procedure for checking the flow cups for wear and tear has been revised to include two alternative methods (one using a certified reference material or secondary working standard, the other using a certified flow cup) and has been moved to an informative annex;
- e) the former Annex A on the use of flow cups for the adjustment of paint consistency has been deleted;
- f) a new annex describing the conversion of flow times from one temperature to another has been added.

Introduction

The first edition of this International Standard, published in 1972, specified only one flow cup of orifice diameter 4 mm. The second edition specified three flow cups of orifice diameter 3 mm, 4 mm and 6 mm. The third edition corrected errors in Figures 2 and 4 and the equations for those figures. The fourth edition specified four flow cups of orifice diameter 3 mm, 4 mm, 5 mm and 6 mm. The main changes made in this fifth edition are given in the foreword.

As is well known, many countries over the years have developed their own standard flow cups and the difficulty in correlation between them has led to considerable confusion in comparing values. The standardization of an improved design of flow cup has been recommended after careful consideration, by an expert working group, of the role of flow cups for the measurement of the flow time of paints, varnishes and related products.

It is recognized that flow times are reproducible only for products of Newtonian or near-Newtonian flow properties. This effectively limits their practical use. Nevertheless, for checking purposes, these flow cups do serve a useful purpose. Furthermore, the measurement of flow time is often used to confirm the application consistency.

Paints often contain flow-arresting agents to confer increased viscosity. Such paints exhibit non-Newtonian flow properties. Their viscosity during application can only be properly assessed using viscometers such as that described in ISO 3219.

Resins and varnishes can exhibit Newtonian or near-Newtonian flow at much higher viscosities than most paints and, where this applies, flow cups can provide a useful means of controlling the consistency. To meet this requirement, this International Standard provides flow cups suitable for viscosities up to about 700 mm²/s.

With thixotropic materials, stirring or other such mechanical disturbance immediately before testing will reduce the flow time compared with that for an unstirred sample. With such materials, uncertain and variable flow time values are obtained with all the flow cups. The repeatability and reproducibility limits given in Clause 9 cannot be achieved in the determination of the flow time of such materials.

Copyright International Organization for Standardization

Paints and varnishes — Determination of flow time by use of flow cups

1 Scope

1.1 This International Standard specifies a method for determining the flow time of paints, varnishes and related products that can be used to control consistency.

1.2 Four flow cups of similar dimensions, but having orifice diameters of 3 mm, 4 mm, 5 mm and 6 mm, are specified. Two methods for checking the flow cups for wear and tear are given (see Annex A).

Flow cups with a replaceable jet are not covered by this International Standard as the close tolerances on the supply of the material under test to the jet are not met.

Commonly used dipping flow cups are also not covered by this International Standard. In general, the fabrication tolerances for such flow cups are greater than those of the flow cups specified in this International Standard. Therefore flow time determinations with dipping flow cups give a precision which is lower than that obtained with the flow cups specified in this International Standard (see Clause 9).

1.3 The method is limited to testing materials for which the breakpoint of the flow from the orifice of the flow cup can be determined with certainty. This point is difficult to determine and reproduce for materials with flow times near the upper limit of the measurement range (100 s) due to slowing-down effects.

2 Normative references

The following referenced documents are indispensable for the application of this document. For dated references, only the edition cited applies. For undated references, the latest edition of the referenced document (including any amendments) applies.

ISO 1513, *Paints and varnishes — Examination and preparation of test samples*

ISO 15528, *Paints, varnishes and raw materials for paints and varnishes — Sampling*

3 Terms and definitions

For the purposes of this document, the following terms and definitions apply.

3.1

flow time

t

time that elapses from the moment when the material under test starts to flow from the orifice of the filled flow cup to the moment when the flow stream of material first breaks off close to the orifice

3.2

Newtonian flow

type of flow exhibited by a material in which, at a constant temperature, the ratio of the shear stress to the shear rate does not vary either with time or with the shear rate

NOTE When variations in this ratio are small, the effect on viscosity of mechanical disturbance, such as stirring, is negligible and the material is said to have near-Newtonian flow.

3.3 non-Newtonian flow
type of flow exhibited by a material in which, at a constant temperature, the ratio of the shear stress to the shear rate varies either with time or with shear rate

3.4 kinematic viscosity
 ν
ratio of the dynamic viscosity to the density of the liquid

NOTE The SI base unit for kinematic viscosity is metres squared per second (m^2/s).

4 Temperature considerations

The effect of temperature on flow time is highly significant with respect to application properties and varies with the type of product.

For reference purposes, $(23,0 \pm 0,5) \text{ }^\circ\text{C}$ is specified as the test temperature in this International Standard. However, it might be more convenient to carry out comparative testing at some other agreed temperature (for example, $25 \text{ }^\circ\text{C}$) because of prevailing temperature conditions (see also Annex B).

For control by flow time, the test sample and flow cup shall be conditioned to an agreed or specified temperature and it shall be ensured that the temperature variation does not exceed $0,5 \text{ }^\circ\text{C}$ during testing. The flow cup shall be in a place which is free from draughts.

5 Apparatus

5.1 Flow cups

5.1.1 Dimensions

The dimensions of the ISO flow cups and the tolerances allowed in manufacture shall be as shown in Figure 1.

NOTE The most critical tolerance is the internal diameter of the jet of the flow cup, because the flow time is inversely proportional to the fourth power of this dimension.

5.1.2 Material

The jet of the flow cup shall be made of stainless steel or sintered carbide, and the body of the flow cup shall be made of a material which is corrosion-resistant and is not affected by the products to be tested.

5.1.3 Construction

The dimensions not specified, such as wall thickness, shall be such that no distortion of the flow cup can occur in use. The external shape should preferably be as shown in Figure 1, but may be modified for convenience of use, or manufacture, provided that the protruding jet of the flow cup is protected from accidental damage as far as possible by an external protective sleeve. Such a protective sleeve shall not be immediately adjacent to the jet, so as to prevent any capillary action when the material under test flows out.

Flow cups having an additional jacket for temperature control are preferred.

5.1.4 Finish

The interior surfaces of the flow cups, including the orifice, shall be smooth and free from turning marks, crevices, ledges and burrs which might cause random flow or trap sample or cleaning material.

NOTE The standard of finish required is equivalent to a maximum roughness Ra (as defined in ISO 4287) of not more than $0,5 \text{ } \mu\text{m}$.

Dimensions in millimetres,
roughness in micrometres

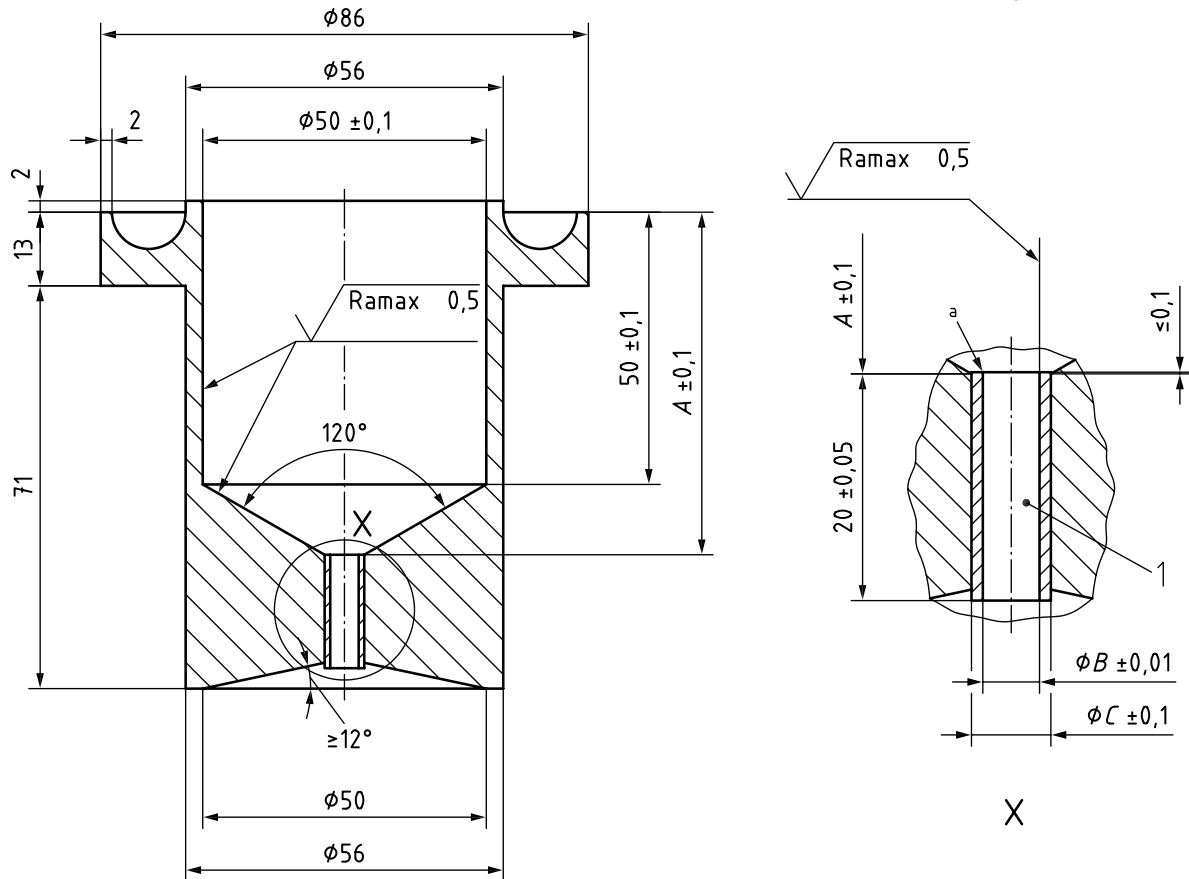

Key

1 jet

a Sharp edge (not rounded).

Dimension	Values ^a for the flow cups given			
	3-mm (No 3) flow cup	4-mm (No 4) flow cup	5-mm (No 5) flow cup	6-mm (No 6) flow cup
A	63	62,7	62,4	62,1
B	3	4	5	6
C	5	6	7	8

^a For tolerances, see the enlarged section of the jet.

Figure 1 — Flow cup

5.1.5 Measurement range

Flow cups shall be used within the measurement range given in Table 1. Only in this range can meaningful data be obtained. In addition, the conversion of flow time to kinematic viscosity and *vice versa*, shall be carried out using the equations given in Table 1.

Table 1 — Measurement range of flow cups and conversion of flow time to kinematic viscosity and vice versa

Flow cup	Flow time, t s	Kinematic viscosity, ν mm ² /s	Measurement range s
No 3	$t = \frac{\nu}{0,89} + \sqrt{451,5 + \left(\frac{\nu}{0,89}\right)^2}$	$\nu = 0,443 \times t - \frac{200}{t}$	$30 \leq t \leq 100$
No 4	$t = \frac{\nu}{2,74} + \sqrt{146,0 + \left(\frac{\nu}{2,74}\right)^2}$	$\nu = 1,37 \times t - \frac{200}{t}$	$30 \leq t \leq 100$
No 5	$t = \frac{\nu}{6,56} + \sqrt{67,1 + \left(\frac{\nu}{6,56}\right)^2}$	$\nu = 3,28 \times t - \frac{220}{t}$	$30 \leq t \leq 100$
No 6	$t = \frac{\nu}{13,8} + \sqrt{82,6 + \left(\frac{\nu}{13,8}\right)^2}$	$\nu = 6,90 \times t - \frac{570}{t}$	$30 \leq t \leq 100$

The curves corresponding to the equations given in Table 1 are plotted in Figure 2.

NOTE These curves are given for information only.

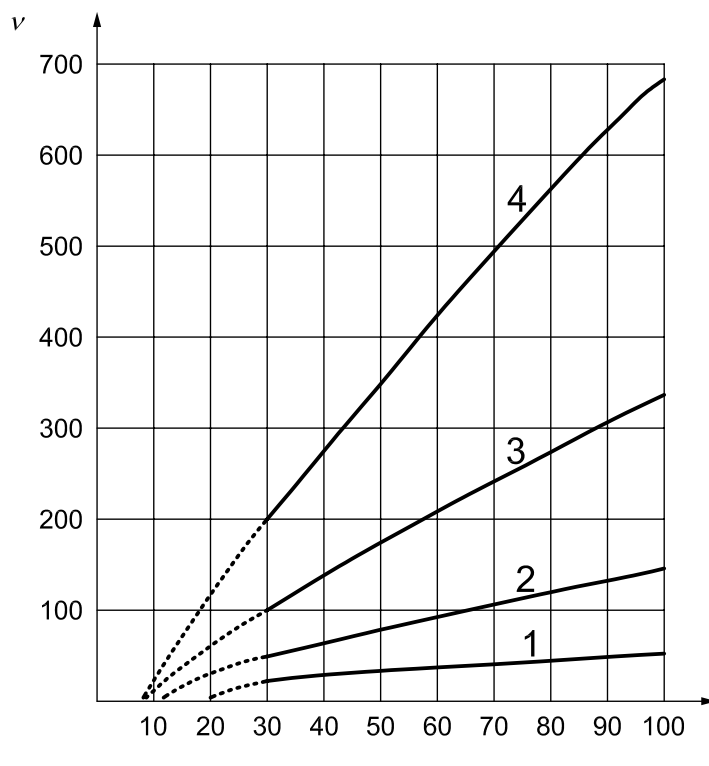
**Key**

- 1 3-mm flow cup
- 2 4-mm flow cup
- 3 5-mm flow cup
- 4 6-mm flow cup
- t flow time, in seconds
- ν kinematic viscosity, in millimetres squared per second

Figure 2 — Conversion curves for 3-mm, 4-mm, 5-mm and 6-mm flow cups

5.1.6 Marking

Each flow cup shall have the following inscriptions permanently and legibly marked on it:

- a) designation of flow cup: ISO 2431, No 3, No 4, No 5 or No 6;
- b) manufacturer's identification number;
- c) manufacturer's name or trade mark.

5.1.7 Care and checking of flow cups

Clean the flow cup immediately after use and before the sample starts to dry, using a suitable solvent. Never use metal tools or a wire scourer for cleaning purposes. If the orifice becomes contaminated with dried deposits, soften these with a suitable solvent and clean carefully, for example with a soft cloth pulled through the orifice.

Check the flow cups periodically for wear and tear by one of the procedures specified in Annex A.

5.2 Supplementary apparatus

5.2.1 Thermometer, graduated at intervals of 0,2 °C or finer.

5.2.2 Stand, suitable for holding the flow cup and provided with levelling screws.

5.2.3 Spirit level, preferably of the circular type.

5.2.4 Flat glass plate or **straight-edge scraper**.

5.2.5 Stopwatch, or other suitable timing-device, with scale divisions of 0,2 s or finer.

5.2.6 Temperature-controlled room or enclosure, capable of maintaining the flow cup and sample at a recommended, constant temperature (see Clause 4).

NOTE This will not be needed if the flow cup has a jacket for temperature control.

6 Sampling

Take a representative sample of the material to be tested, as described in ISO 15528. Examine and prepare the sample for testing, as described in ISO 1513.

A sample of 150 ml is sufficient for carrying out one test. Take care to mix the material thoroughly, while at the same time avoiding, as far as possible, loss of solvent by evaporation.

7 Procedure

7.1 Preliminary check for Newtonian flow

7.1.1 Choose a flow cup that will give a flow time of between 30 s and 100 s for the test material.

7.1.2 Determine the flow time as specified in 7.2.

7.1.3 Repeat the determination, but this time allow the material to remain in the flow cup for 60 s before removing the finger used to close off the orifice (see 7.2.4).

7.1.4 If the second result differs from the first result by more than 10 %, the material shall be deemed to be non-Newtonian and therefore unsuitable for consistency control by flow time measurement.

7.2 Determination of flow time

7.2.1 Choice of flow cup

Choose a flow cup that will give a flow time of between 30 s and 100 s for the test material.

7.2.2 Temperature adjustment

Adjust the temperature of the sample, and the flow cup, to $(23,0 \pm 0,5) ^\circ\text{C}$, or to an alternative agreed temperature (see Clause 4).

NOTE If the temperature-controlled enclosure (5.2.6) is used, it is advisable to condition the flow cup and the sample by placing them in the enclosure before use.

The sample shall be considered ready for test immediately after any air bubbles entrained during the preparation procedure have dispersed. Carry out a final check that the temperature of the sample is within $0,5 ^\circ\text{C}$ of the agreed test temperature immediately prior to filling the flow cup.

7.2.3 Preparation of the flow cup

Place the flow cup on the stand (5.2.2), in a position free from draughts and, by using the spirit level (5.2.3) and adjusting the levelling screws of the stand, ensure that the upper rim of the flow cup is in a horizontal plane.

7.2.4 Filling the flow cup

With the orifice closed by a finger, fill the flow cup with the well stirred, bubble-free sample, pouring slowly to avoid the formation of air bubbles. If any bubbles are formed, allow them to rise to the surface and remove them.

NOTE If the flow cup has been properly levelled, the sample will overflow evenly over the rim into the gallery.

Remove any meniscus formed either by drawing the straight-edge scraper (see 5.2.4) over the entire rim of the flow cup or by sliding over the rim a flat glass plate with rounded edges so that no air bubbles form between the glass and the surface of the sample, subsequently drawing this plate horizontally across the rim of the flow cup so that, when the plate is removed, the level of the sample coincides with the top rim of the flow cup.

7.2.5 Measurement of flow time

Place a suitable receiver under the flow cup so that the distance between the orifice of the flow cup and the surface of the received sample is never less than 100 mm. Remove the finger from the orifice and simultaneously start the timing-device (5.2.5), stopping it as soon as the first break occurs in the stream of sample close to the orifice. Record the rounded flow time to the nearest 0,5 s.

7.2.6 Repeat determinations

Carry out a second determination on another portion of the originally prepared sample and check carefully that the temperature of testing is within the prescribed limits. Record the flow time to the nearest 0,5 s. Calculate the mean of the two determinations.

If the two determinations differ by more than 5 %, carry out a third determination. If the third determination and either of the previous determinations do not differ by more than 5 %, discard the outlier. Calculate the result as the mean of the two accepted determinations.

If the third determination does not provide this measure of agreement, the method of test is unlikely to be suitable because of non-Newtonian flow behaviour, and consideration shall be given to other methods of test, e.g. to measuring the viscosity using a rotational viscometer.

8 Marking of products tested

The product tested may be marked with a marking indicating the results of the test.

If such a marking is made, it shall comprise a reference to this International Standard, the designation number of the flow cup used and the flow time, in seconds. For example,

ISO 2431 — 5 — 65

Number of this International Standard — Designation number of flow cup — Flow time

9 Precision

9.1 General

An interlaboratory test was planned and executed, and the results evaluated, in accordance with ISO 5725-2. Eleven laboratories participated in the test. Liquids were tested using 4 mm and 6 mm flow cups. Except for the varnish when tested using the 6 mm flow cup, the liquids showed Newtonian flow behaviour. The flow behaviour of the varnish when tested using the 6 mm flow cup was nearly Newtonian, but, when the preliminary

check specified in 7.1 was carried out, the second result did not differ from the first result by more than 10 % (see 7.1.4).

9.2 Repeatability limit r

The value below which the absolute difference between two single test results, each the mean of duplicates, obtained on identical material by one operator in one laboratory within a short interval of time using the standardized test method, may be expected to lie with a 95 % probability is approximately 2 s.

Details of the results are given in Table 2.

Table 2 — Repeatability limit r

Test liquid	Orifice diameter mm	Mean value of flow time s	Repeatability limit r s
Engine oil	4	55	1,7
Varnish, based on organic solvents	4	56	1,7
Engine oil	6	60	2,6
Varnish, based on organic solvents	6	43	1,7

9.3 Reproducibility limit R

The value below which the absolute difference between two single test results, each the mean of duplicates, obtained by operators on identical material in different laboratories using the standardized test method, may be expected to lie with a 95 % probability is approximately 3 s for the 4 mm flow cup and approximately 6 s for the 6 mm flow cup.

Details of the results are given in Table 3.

Table 3 — Reproducibility limit R

Test liquid	Orifice diameter mm	Mean value of flow time s	Reproducibility limit R s
Engine oil	4	55	2,2
Varnish, based on organic solvents	4	56	3,2
Engine oil	6	60	3,9
Varnish, based on organic solvents	6	43	5,5

10 Test report

The test report shall include at least the following information:

- a) all details necessary to identify the product tested;
- b) a reference to this International Standard (ISO 2431) and to designation (No 3, No 4, No 5 or No 6) of the flow cup used;
- c) the manufacturer's identification number of the flow cup used;
- d) the temperature of testing;
- e) the flow time (for referee purposes, individual values shall also be reported);

- f) any deviation, by agreement or otherwise, from the test procedure described;
- g) any unusual features (anomalies) observed during the test;
- h) the date of the test.

Annex A (normative)

Checking flow cups for wear and tear

A.1 General

Two methods can be used to check flow cups. In method A, the flow cup is checked by using a certified reference material (CRM) or secondary working standard (SWS). In method B, the flow cup is checked against a certified flow cup.

A.2 Standards required

A.2.1 Certified reference material (CRM), comprising a standard Newtonian oil of known kinematic viscosity and known shelf life. The CRM shall be certified by an accredited laboratory.

A.2.2 Secondary working standard (SWS), comprising e.g. a commercially available engine oil or other substance with a kinematic viscosity determined by testing representative subsamples at least three times, utilizing an instrument previously verified using a CRM, statistically analysing the results and, after the removal of any outliers, calculating the arithmetic mean of the results.

Store SWSs in containers which will retain the integrity of the SWS, out of direct sunlight, at a temperature not exceeding 10 °C.

An SWS may be used up to three times. It shall then be tempered and allow to stand for devolatilization for at least 3 h.

A.2.3 Flow cup, certified by an accredited laboratory.

A.3 Method A — Checking using a CRM or SWS

To check a particular flow cup, use a CRM or an SWS of known kinematic viscosity at $(23 \pm 0,2)$ °C. Choose a CRM or SWS with a flow time which is in the range 30 s to 100 s, and preferably near the midpoint of this range, for the flow cup concerned.

Condition the CRM or SWS, and the flow cup being checked, at $(23 \pm 0,2)$ °C for at least 2 h. Determine the flow time of the CRM or SWS, following the procedure specified in Clause 7, to the nearest 0,2 s.

Carry out the determination three times.

Calculate the mean value of the three determinations and, using the appropriate equation in Table 1, the kinematic viscosity of the liquid as given by the flow cup.

Calculate the deviation between the certified and the measured viscosity using Equation (A.1):

$$\Delta v = \frac{(v_{\text{measured}} - v_{\text{certified}}) \times 100}{v_{\text{certified}}} \quad (\text{A.1})$$

where

Δv is the deviation between the certified and the measured viscosity, expressed as a percentage;

v_{measured} is the viscosity calculated from the flow time determined, in square millimetres per second;

$v_{\text{certified}}$ is the viscosity of the CRM or SWS, in square millimetres per second.

If the two values of the calculated kinematic viscosity obtained do not differ by more than 3 %, the flow cup is deemed to be satisfactory for use.

NOTE When using an SWS, instead of calculating the kinematic viscosity the flow times measured can be used directly to calculate the deviation, expressed as Δt [see Equation (A.2)].

A.4 Method B — Checking using a certified flow cup

To check a particular flow cup, use a certified reference flow cup of the same type. Choose an SWS with a flow time which is in the range 30 s to 100 s, and preferably near the midpoint of this range, for the flow cup concerned.

Condition the certified reference flow cup, the flow cup being checked and the SWS in a temperature-controlled enclosure at a temperature between 20 °C and 25 °C for at least 2 h. During this conditioning and the subsequent flow time measurement, the temperature shall remain constant to within $\pm 0,2$ °C. Determine the flow time of the SWS, following the procedure specified in Clause 7, to the nearest 0,2 s.

Carry out the determination three times. Calculate the result as the mean of the three determinations.

Calculate the deviation between the flow time given by the certified reference flow cup and that given by the flow cup being checked, using Equation (A.2):

$$\Delta t = \frac{(t_{\text{checking}} - t_{\text{certified}}) \times 100}{t_{\text{certified}}} \quad (\text{A.2})$$

where

Δt is the deviation between the flow time given by the certified flow cup and that given by the flow cup being checked, expressed as a percentage;

t_{checking} is the flow time determined with the flow cup being checked, in seconds;

$t_{\text{certified}}$ is the flow time determined with the certified reference flow cup, in seconds.

If the two values of the determined flow times obtained do not differ by more than 3 % (absolute), the flow cup is deemed to be satisfactory for use.

Annex B (informative)

Conversion of flow times from one temperature to another

If the flow time cannot be measured at the specified temperature, it is necessary to convert it from the measurement temperature. This annex describes an interpolation method for the conversion. The method is not suitable for the extrapolation of data outside the defined temperature range.

The Vogel equation is a well-proven and frequently used approximation of the viscosity/temperature behaviour of paints. It is given, for flow times, by Equation (B.1):

$$\ln t = A + \frac{B}{T + C} \quad (\text{B.1})$$

in which the constants A , B and C are given by Equations (B.2) to (B.4):

$$C = \frac{(\ln t_1 - \ln t_3)(T_1 - T_2)T_3 - (\ln t_1 - \ln t_2)(T_1 - T_3)T_2}{(\ln t_1 - \ln t_2)(T_1 - T_3) - (\ln t_1 - \ln t_3)(T_1 - T_2)} \quad (\text{B.2})$$

$$A = \frac{(T_1 + C)\ln t_1 - (T_2 + C)\ln t_2}{(T_1 - T_2)} \quad (\text{B.3})$$

$$B = (T_2 + C)(\ln t_2 - A) \quad (\text{B.4})$$

where

- T_1 is the lower temperature limit, in degrees Celsius;
- T_2 is the temperature in the middle of the range, in degrees Celsius;
- T_3 is the upper temperature limit, in degrees Celsius;
- t_1 is the flow time, in seconds, at temperature T_1 ;
- t_2 is the flow time, in seconds, at temperature T_2 ;
- t_3 is the flow time, in seconds, at temperature T_3 .

The conversion of flow times from one temperature to another only gives reliable results if

- the chosen temperature range $T_3 - T_1$ is ≤ 20 °C;
- the conversion does not involve extrapolation outside the defined temperature range.

If the constants A , B and C are known (for an example, see Table B.1), the interpolation data within the interval from T_1 to T_3 can be calculated using Equation (B.1) and tabulated (for an example, see Table B.2). Additionally, the data can be plotted as an interpolation curve (for an example, see Figure B.1).

Table B.1 — Calculation of the constants A , B and C

Temperature °C		Flow time s		Calculated values of A , B and C	
T_1	16	t_1	62	A	3,641
T_2	23	t_2	54	B	8,552
T_3	30	t_3	50	C	1,609

Table B.2 — Interpolated values of flow time between the three base values

Temperature °C	Flow time s
16	62,0
17	60,4
18	59,0
19	57,8
20	56,7
21	55,7
22	54,8
23	54,0
24	53,3
25	52,6
26	52,0
27	51,4
28	50,9
29	50,4
30	50,0

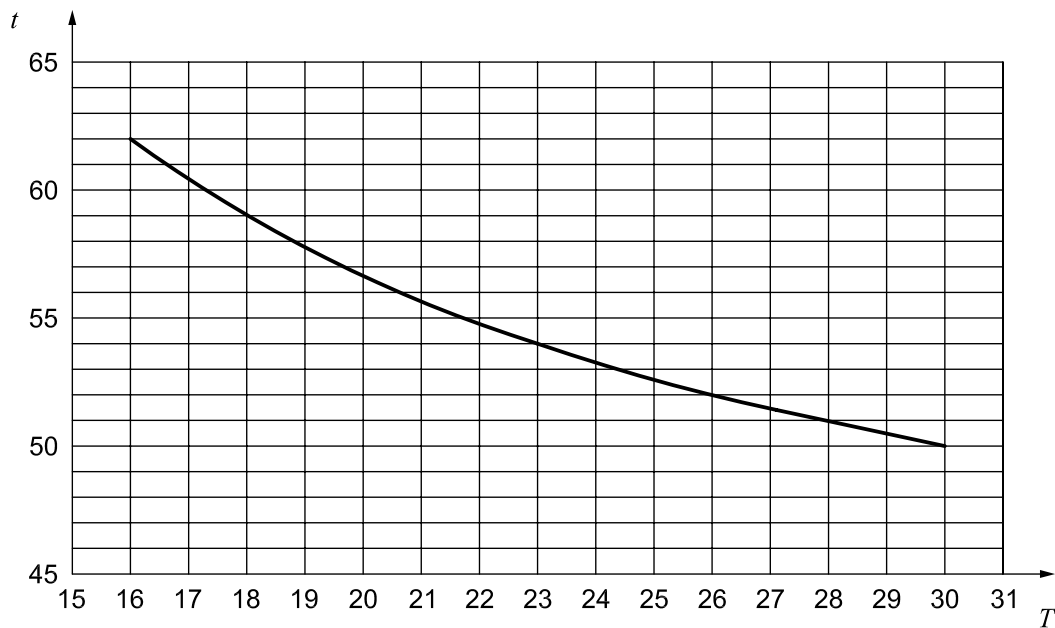

Key

t flow time, in seconds

T temperature, in degrees Celsius

Figure B.1 — Example of relationship between flow-time t and temperature T

Bibliography

- [1] ISO 3219, *Plastics — Polymers/resins in the liquid state or as emulsions or dispersions — Determination of viscosity using a rotational viscometer with defined shear rate*
- [2] ISO 4287, *Geometrical Product Specifications (GPS) — Surface texture: Profile method — Terms, definitions and surface texture parameters*
- [3] ISO 5725-2, *Accuracy (trueness and precision) of measurement methods and results — Part 2: Basic method for the determination of repeatability and reproducibility of a standard measurement method*

ICS 87.040

Price based on 15 pages