

---

---

**Assembly tools for screws and nuts —  
Machine-operated screwdriver bits —**

**Part 2:  
Screwdriver bits for cross-recessed head  
screws**

*Outils de manœuvre pour vis et écrous — Embouts tournevis à machine —*

*Partie 2: Embouts tournevis pour vis à empreinte cruciforme*

---

---

Reference number  
ISO 2351-2:2002(E)

© ISO 2002

**PDF disclaimer**

This PDF file may contain embedded typefaces. In accordance with Adobe's licensing policy, this file may be printed or viewed but shall not be edited unless the typefaces which are embedded are licensed to and installed on the computer performing the editing. In downloading this file, parties accept therein the responsibility of not infringing Adobe's licensing policy. The ISO Central Secretariat accepts no liability in this area.

Adobe is a trademark of Adobe Systems Incorporated.

Details of the software products used to create this PDF file can be found in the General Info relative to the file; the PDF-creation parameters were optimized for printing. Every care has been taken to ensure that the file is suitable for use by ISO member bodies. In the unlikely event that a problem relating to it is found, please inform the Central Secretariat at the address given below.

© ISO 2002

All rights reserved. Unless otherwise specified, no part of this publication may be reproduced or utilized in any form or by any means, electronic or mechanical, including photocopying and microfilm, without permission in writing from either ISO at the address below or ISO's member body in the country of the requester.

ISO copyright office  
Case postale 56 • CH-1211 Geneva 20  
Tel. + 41 22 749 01 11  
Fax + 41 22 749 09 47  
E-mail [copyright@iso.ch](mailto:copyright@iso.ch)  
Web [www.iso.ch](http://www.iso.ch)

Printed in Switzerland

## Foreword

ISO (the International Organization for Standardization) is a worldwide federation of national standards bodies (ISO member bodies). The work of preparing International Standards is normally carried out through ISO technical committees. Each member body interested in a subject for which a technical committee has been established has the right to be represented on that committee. International organizations, governmental and non-governmental, in liaison with ISO, also take part in the work. ISO collaborates closely with the International Electrotechnical Commission (IEC) on all matters of electrotechnical standardization.

International Standards are drafted in accordance with the rules given in the ISO/IEC Directives, Part 3.

Draft International Standards adopted by the technical committees are circulated to the member bodies for voting. Publication as an International Standard requires approval by at least 75 % of the member bodies casting a vote.

Attention is drawn to the possibility that some of the elements of this part of ISO 2351 may be the subject of patent rights. ISO shall not be held responsible for identifying any or all such patent rights.

International Standard ISO 2351-2 was prepared by Technical Committee ISO/TC 29, *Small tools*, Subcommittee SC 10, *Assembly tools for screws and nuts, pliers and nippers*.

ISO 2351 consists of the following parts, under the general title *Assembly tools for screws and nuts — Machine-operated screwdriver bits*:

- *Part 1: Screwdriver bits for slotted head screws*
- *Part 2: Screwdriver bits for cross-recessed head screws*
- *Part 3: Screwdriver bits for hexagon socket screws*

# Assembly tools for screws and nuts — Machine-operated screwdriver bits —

## Part 2:

## Screwdriver bits for cross-recessed head screws

### 1 Scope

This part of ISO 2351 prescribes the technical specifications for machine-operated screwdriver bits for cross-recessed head screws. It applies to bits with male hexagon drive or with cylindrical flat end drive as defined in ISO 1173, and to tips for screwdrivers as defined in ISO 8764-1.

It also gives recommended combinations between tips and bits.

### 2 Normative references

The following normative documents contain provisions which, through reference in this text, constitute provisions of this part of ISO 2351. For dated references, subsequent amendments to, or revisions of, any of these publications do not apply. However, parties to agreements based on this part of ISO 2351 are encouraged to investigate the possibility of applying the most recent editions of the normative documents indicated below. For undated references, the latest edition of the normative document referred to applies. Members of ISO and IEC maintain registers of currently valid International Standards.

ISO 1173, *Assembly tools for screws and nuts — Drive ends for hand- and machine-operated screwdriver bits and connecting parts — Dimensions, torque testing*

ISO 8764-1, *Assembly tools for screws and nuts — Screwdrivers for cross-recessed head screws — Part 1: Driver points*

### 3 Dimensions

Figure 1 and Table 1 show the recommended combinations of screwdriver bits for cross-recessed head screws, forms PH and PZ in accordance with ISO 8764-1.

The shape of the liaison between the tip and the driver end is at the discretion of the manufacturer.

### 4 Technical requirements

The bits shall have a complete heat treatment.

The technical specifications of bits are the same as those for screwdrivers in accordance with ISO 8764-1.

### 5 Torque test

Torque testing will be carried out in accordance with ISO 8764-1.

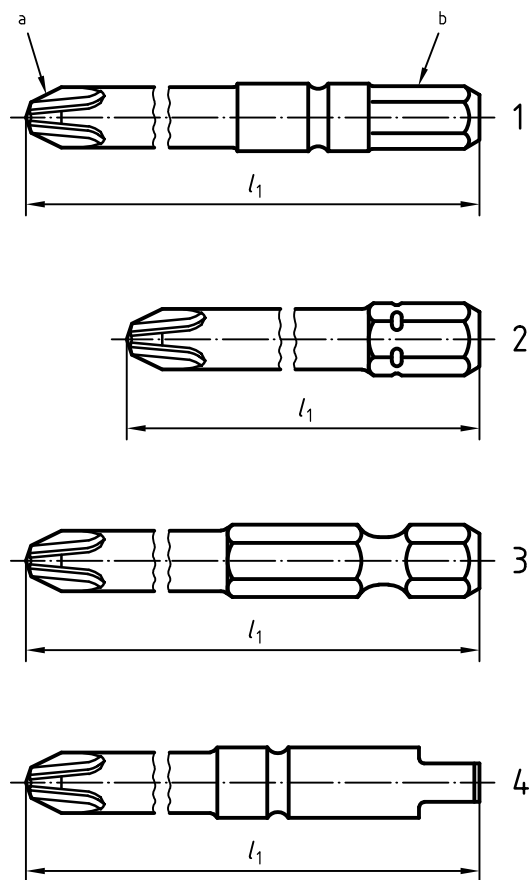

**Key**

- 1 Form A
- 2 Form C
- 3 Form E
- 4 Form G

<sup>a</sup> Part (tip) in contact with the screw (in accordance with ISO 8764-1)

<sup>b</sup> Driver end (in accordance with ISO 1173)

**Figure 1 — Forms of screwdriver bits (PH and PZ)**

Table 1 — Recommended combinations between tip and driver end

Dimensions en millimetres

PH or PZ tip size number (in accordance with ISO 8764-1)	Male hexagon or cylindrical flat end of form and dimensions (in accordance with ISO 1173)																
	A 3	A 5,5	C 4	C 6,3				C 8		E 6,3			E 8	E 11,2	G 7		
	$l_1 \pm 2$																
	50	50	28	25	32	40	50	32	40	50	70	89	152	53	75	53	70
0	x		x	x	x	x	x			x	x	x	x				
1	x	x	x	x	x	x	x	x	x	x	x	x	x	x		x	x
2		x	x	x	x	x	x	x	x	x	x	x	x	x	x	x	x
3		x		x	x	x	x	x	x	x	x	x	x	x	x		
4								x	x					x	x		

## 6 Designation

A screwdriver bit in accordance with this part of ISO 2351 is designated by:

- "Bit";
- reference to this part of ISO 2351, i.e. ISO 2351-2;
- the form and the dimensions of the drive end (in accordance with ISO 1173);
- the form and number of the tips (in accordance with ISO 8764-1).

EXAMPLE 1 A screwdriver bit form PH, tip size number 2 (in accordance with ISO 8764-1) with a drive end E 11,2 (in accordance with ISO 1173) is designated as follows:

**Bit ISO 2351-2 E 11,2 PH 2**

EXAMPLE 2 A screwdriver bit form PZ, tip size number 2 (in accordance with ISO 8764-1) with a drive end E 11,2 (in accordance with ISO 1173) is designated as follows:

**Bit ISO 2351-2 E 11,2 PZ 2**

## 7 Marking

Screwdriver bits in accordance with this part of ISO 2351 shall be marked permanently and legibly with:

- the name of the manufacturer or supplier;
- the tip form PH or PZ and the number of the end.

For male hexagons A 3 and C 4 the marking shall be given only on the smallest commonly used packaging unit.

## Bibliography

- [1] ISO 1703, *Assembly tools for screws and nuts — Nomenclature*
- [2] ISO 2351-1, *Assembly tools for screws and nuts — Machine-operated screwdriver bits — Part 1: Screwdriver bits for slotted head screws*
- [3] ISO 2351-3, *Assembly tools for screws and nuts — Machine-operated screwdriver bits — Part 3: Screwdriver bits for hexagon socket screws*

---

---

**ICS 25.140.01**

Price based on 4 pages

© ISO 2002 – All rights reserved