**Road vehicles — M14 × 1,25 compact
spark-plugs with flat seating and 19 mm
hexagon and their cylinder head housing**

Véhicules routiers — Bougies d'allumage M14 × 1,25 «compactes» à siège plat et à hexagone de 19 mm et leur logement dans la culasse



PDF disclaimer

This PDF file may contain embedded typefaces. In accordance with Adobe's licensing policy, this file may be printed or viewed but shall not be edited unless the typefaces which are embedded are licensed to and installed on the computer performing the editing. In downloading this file, parties accept therein the responsibility of not infringing Adobe's licensing policy. The ISO Central Secretariat accepts no liability in this area.

Adobe is a trademark of Adobe Systems Incorporated.

Details of the software products used to create this PDF file can be found in the General Info relative to the file; the PDF-creation parameters were optimized for printing. Every care has been taken to ensure that the file is suitable for use by ISO member bodies. In the unlikely event that a problem relating to it is found, please inform the Central Secretariat at the address given below.

© ISO 2001

All rights reserved. Unless otherwise specified, no part of this publication may be reproduced or utilized in any form or by any means, electronic or mechanical, including photocopying and microfilm, without permission in writing from either ISO at the address below or ISO's member body in the country of the requester.

ISO copyright office
Case postale 56 • CH-1211 Geneva 20
Tel. + 41 22 749 01 11
Fax + 41 22 749 09 47
E-mail copyright@iso.ch
Web www.iso.ch

Printed in Switzerland

Foreword

ISO (the International Organization for Standardization) is a worldwide federation of national standards bodies (ISO member bodies). The work of preparing International Standards is normally carried out through ISO technical committees. Each member body interested in a subject for which a technical committee has been established has the right to be represented on that committee. International organizations, governmental and non-governmental, in liaison with ISO, also take part in the work. ISO collaborates closely with the International Electrotechnical Commission (IEC) on all matters of electrotechnical standardization.

International Standards are drafted in accordance with the rules given in the ISO/IEC Directives, Part 3.

The main task of technical committees is to prepare International Standards. Draft International Standards adopted by the technical committees are circulated to the member bodies for voting. Publication as an International Standard requires approval by at least 75 % of the member bodies casting a vote.

Attention is drawn to the possibility that some of the elements of this International Standard may be the subject of patent rights. ISO shall not be held responsible for identifying any or all such patent rights.

ISO 2346 was prepared by Technical Committee ISO/TC 22, *Road vehicles*, Subcommittee SC 1, *Ignition equipment*.

This fifth edition cancels and replaces the fourth edition (ISO 2346:1991), which has been technically revised.

Road vehicles — M14 × 1,25 compact spark-plugs with flat seating and 19 mm hexagon and their cylinder head housing

1 Scope

This International Standard specifies the main characteristics of M14 × 1,25 compact spark-plugs with flat seating and 19 mm hexagon and their cylinder head housing, for use with spark-ignition engines.

2 Normative references

The following normative documents contain provisions which, through reference in this text, constitute provisions of this International Standard. For dated references, subsequent amendments to, or revisions of, any of these publications do not apply. However, parties to agreements based on this International Standard are encouraged to investigate the possibility of applying the most recent editions of the normative documents indicated below. For undated references, the latest edition of the normative document referred to applies. Members of ISO and IEC maintain registers of currently valid International Standards.

ISO 68-1, *ISO general purpose screw threads — Basic profile — Part 1: Metric screw threads*

ISO 261, *ISO general-purpose metric screw threads — General plan*

ISO 965-1:1998, *ISO general purpose metric screw threads — Tolerances — Part 1: Principles and basic data*

ISO 965-3, *ISO general purpose metric screw threads — Tolerances — Part 3: Deviations for constructional screw threads*

ISO 14508:1997, *Road vehicles — Spark-plugs — Terminals*

3 Terminals

The spark-plug terminal may be either of the solid post or threaded type as specified in ISO 14508. A spark-plug with a threaded terminal on which a nut is applied shall respect the dimensions specified for spark-plugs with solid post terminals (see Figure 1).

4 Dimensions and threads

4.1 General

See Figures 1 and 2.

4.2 Gasket

When the spark-plugs have been tightened with a torque of 30 N·m, on threads that are clean, smooth and dry, the gaskets shall be 1,3 mm to 2 mm thick. If the gasket thicknesses are different, a corresponding adjustment to dimensions 9 mm ± 0,3 mm, 9,5 mm ± 0,2 mm and 16 mm max. shall be made.

Non-captive gaskets may be used in special cases.

4.3 Threads for spark-plugs and cylinder heads

4.3.1 General

The threads of M14 × 1,25 spark-plugs and the corresponding tapped holes in the cylinder head shall conform to ISO 68-1, ISO 261, ISO 965-1 and ISO 965-3. Their limiting dimensions and tolerance classes shall be as specified in 4.3.2 and 4.3.3, respectively.

4.3.2 Limiting dimensions

The limiting dimensions are given in Table 1.

Table 1 — Limiting dimensions

Dimensions in millimetres

Dimension	Plug thread (on the finished plug)	Tapped hole in the cylinder head
Major diameter	max.	13,937
	min.	13,725
Pitch diameter	max.	13,125
	min.	12,993
Minor diameter	max.	12,404
	min.	12,181 ^a
^a With a root radius $\geq 0,125$ mm (0,1 P).		

4.3.3 Tolerance classes

The thread tolerance classes of finished M14 × 1,25 compact spark-plugs and of the corresponding tapped holes in the cylinder head are

- 6e for spark-plugs¹⁾, and
- 6H for tapped holes in the cylinder head.

NOTE The initial clearance, $e = 0,063$ mm, between the pitch diameters of the thread and of the tapped hole is intended to prevent the possibility of seizure, as a result of combustion deposits on the bare threads, when removing the spark-plugs. This clearance is also intended to enable spark-plugs with threads in accordance with this International Standard to be fitted in existing tapped holes.

1) In order that spark-plugs complying with this International Standard may also be fitted in existing cylinder heads in extreme cases, the value for the maximum truncation of the minor diameter of the spark-plug base has been slightly reduced with respect to the ISO value. This maximum value of the minor diameter is calculated from a distance of $H/6$ for the maximum truncation instead of the value given by the formula in ISO 965-1:1980, clause 11, according to the formula:

$$\begin{aligned} \text{Minor diameter, maximum} &= d_1 - es - 2(H/4 - H/6) \\ &= (12,647 - 0,063 - 0,180) \text{ mm} = 12,404 \text{ mm} \end{aligned}$$

The value for the *basic profile* remains the same as for the ISO thread: $(12,647 - 0,063) \text{ mm} = 12,584 \text{ mm}$.

5 Other dimensions of spark-plugs and their cylinder head housings

The other dimensions shall be as indicated in Figures 1 and 2.

The contour of the insulator is optional; however, between the reference planes defined for spark-plugs with solid post terminals by the dimensions 20 mm and 24 mm, and for spark-plugs with threaded terminals by the dimensions 17 mm and 21 mm, its largest diameter shall be $12,2 \text{ mm} \pm 0,3 \text{ mm}$.

The non-ribbed insulator design is preferred because it provides superior protection to dielectric tracking between the spark-plug insulator and the cover.

The Z length of the cylinder head housing shall be sufficient to ensure that the end of the spark-plug thread does not project into the combustion chamber at any point when the gasket is tightened to maximum compression.

Details not specified are left to the manufacturer's choice.

6 Installation tightening torque

The installation torque values are applicable to new spark-plugs without lubricant on the threads. If threads are lubricated, the torque value shall be reduced by approximately one-third to avoid overstressing.

Spark-plugs shall be tightened with a torque of

- 20 N·m to 30 N·m in aluminium cylinder heads, and
- 20 N·m to 40 N·m in cast iron cylinder heads.

Engine manufacturers may specify a different torque for the first spark-plug installation.

Dimensions in millimetres

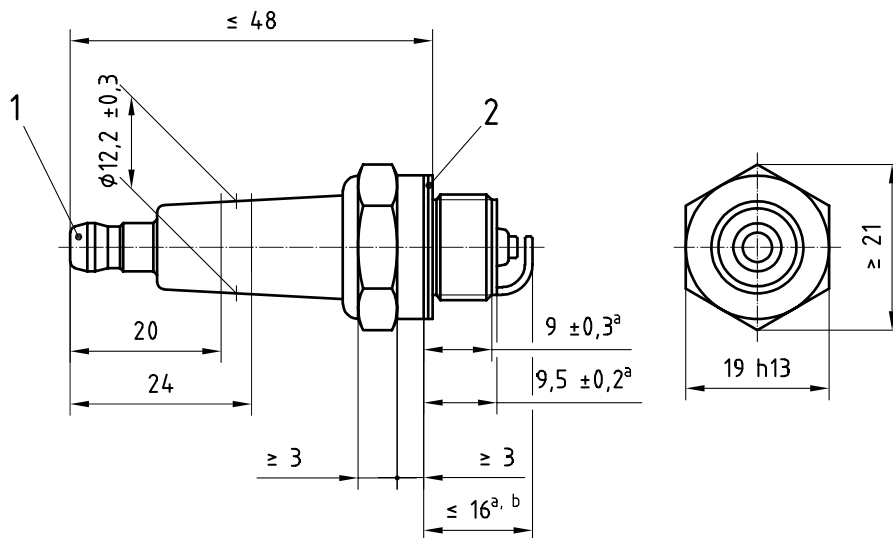

a) With solid post terminal — Preferred design with non-ribbed insulator

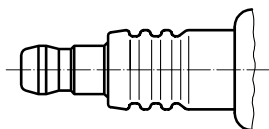

b) With solid post terminal — Traditional design with ribbed insulator ^c

Key

- 1 Solid post terminal ISO 14508
- 2 Captive gasket

a See clause 4.

b This dimension (16 mm max.) is the maximum protrusion of any part of the spark-plug into the combustion chamber, measured from the spark-plug seat, not including the gasket.

c For other dimensions not shown, see Figure 1 a).

Figure 1 — M14 × 1,25 compact spark-plug with flat seating

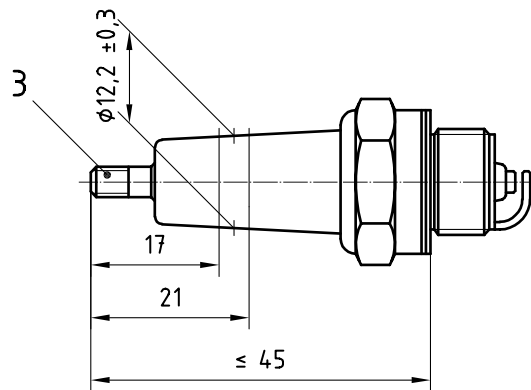

c) With threaded terminal — Preferred design with non-ribbed insulator ^c

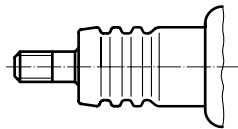

d) With threaded terminal — Traditional design with ribbed insulator ^c

Key

3 Threaded terminal ISO 14508

^c For other dimensions not shown, see Figure 1 a).

Figure 1 — M14 × 1,25 compact spark-plug with flat seating

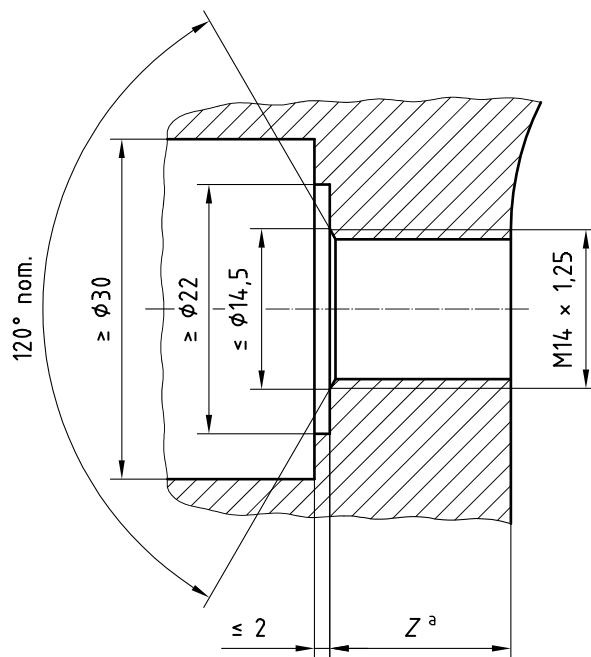

^a See clause 5.

Figure 2 — Cylinder head housing

