Slotted headless screws with shank

Vis sans tête fendues, à fût

PDF disclaimer

This PDF file may contain embedded typefaces. In accordance with Adobe's licensing policy, this file may be printed or viewed but shall not be edited unless the typefaces which are embedded are licensed to and installed on the computer performing the editing. In downloading this file, parties accept therein the responsibility of not infringing Adobe's licensing policy. The ISO Central Secretariat accepts no liability in this area.

Adobe is a trademark of Adobe Systems Incorporated.

Details of the software products used to create this PDF file can be found in the General Info relative to the file; the PDF-creation parameters were optimized for printing. Every care has been taken to ensure that the file is suitable for use by ISO member bodies. In the unlikely event that a problem relating to it is found, please inform the Central Secretariat at the address given below.

© ISO 2003

All rights reserved. Unless otherwise specified, no part of this publication may be reproduced or utilized in any form or by any means, electronic or mechanical, including photocopying and microfilm, without permission in writing from either ISO at the address below or ISO's member body in the country of the requester.

ISO copyright office
Case postale 56 • CH-1211 Geneva 20
Tel. + 41 22 749 01 11
Fax + 41 22 749 09 47
E-mail copyright@iso.org
Web www.iso.org

Published in Switzerland

Foreword

ISO (the International Organization for Standardization) is a worldwide federation of national standards bodies (ISO member bodies). The work of preparing International Standards is normally carried out through ISO technical committees. Each member body interested in a subject for which a technical committee has been established has the right to be represented on that committee. International organizations, governmental and non-governmental, in liaison with ISO, also take part in the work. ISO collaborates closely with the International Electrotechnical Commission (IEC) on all matters of electrotechnical standardization.

International Standards are drafted in accordance with the rules given in the ISO/IEC Directives, Part 2.

The main task of technical committees is to prepare International Standards. Draft International Standards adopted by the technical committees are circulated to the member bodies for voting. Publication as an International Standard requires approval by at least 75 % of the member bodies casting a vote.

Attention is drawn to the possibility that some of the elements of this document may be the subject of patent rights. ISO shall not be held responsible for identifying any or all such patent rights.

ISO 2342 was prepared by Technical Committee ISO/TC 2, *Fasteners*.

This second edition cancels and replaces the first edition (ISO 2342:1972), which has been technically revised.

© ISO 2012

Slotted headless screws with shank

1 Scope

This International Standard specifies the characteristics of slotted headless screws with shank with threads from M1 up to and including M10.

If, in special cases, specifications other than those listed in this International Standard are required, they should be selected from existing International Standards, e.g. ISO 261, ISO 898-5, ISO 965-2, ISO 3506-3, ISO 8839 and ISO 4759-1.

2 Normative references

The following referenced documents are indispensable for the application of this document. For dated references, only the edition cited applies. For undated references, the latest edition of the referenced document (including any amendments) applies.

ISO 225, *Fasteners — Bolts, screws, studs and nuts — Symbols and designations of dimensions*

ISO 261, *ISO general-purpose metric screw threads — General plan*

ISO 898-5, *Mechanical properties of fasteners made of carbon steel and alloy steel — Part 5: Set screws and similar threaded fasteners not under tensile stresses*

ISO 965-2, *ISO general purpose metric screw threads — Tolerances — Part 2: Limits of sizes for general purpose external and internal screw threads — Medium quality*

ISO 3269, *Fasteners — Acceptance inspection*

ISO 3506-3, *Mechanical properties of corrosion-resistant stainless-steel fasteners — Part 3: Set screws and similar fasteners not under tensile stress*

ISO 4042, *Fasteners — Electroplated coatings*

ISO 4753, *Fasteners — Ends of parts with external ISO metric thread*

ISO 4759-1, *Tolerances for fasteners — Part 1: Bolts, screws, studs and nuts — Product grades A, B and C*

ISO 6157-1, *Fasteners — Surface discontinuities — Part 1: Bolts, screws and studs for general requirements*

ISO 8839, *Mechanical properties of fasteners — Bolts, screws, studs and nuts made of non-ferrous metals*

ISO 10683, *Fasteners — Non-electrolytically applied zinc flake coatings*

3 Dimensions

See Figure 1 and Table 1.

Symbols and designations of dimensions are specified in ISO 225.

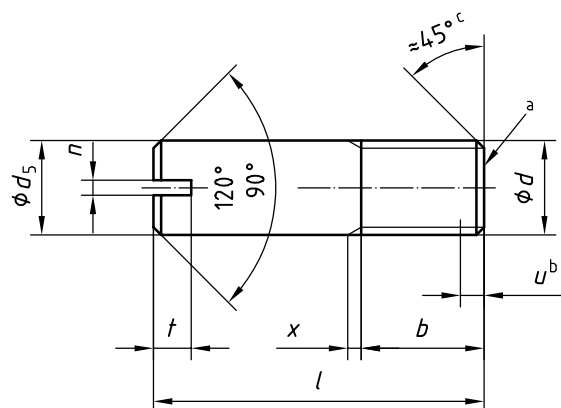

- ^a Flat point according to ISO 4753.
- ^b Incomplete thread $u \leq 2P$.
- ^c The 45° angle applies only to the portion of the point situated below the root diameter of the thread.

Figure 1

Table 1 — Dimensions

Dimensions in millimetres

Thread (<i>d</i>)		M1	M1,2	M1,6	M2	M2,5	M3	(M3,5) ^c	M4	M5	M6	M8	M10
<i>P</i> ^a		0,25	0,25	0,35	0,4	0,45	0,5	0,6	0,7	0,8	1	1,25	1,5
<i>b</i>	$+2P_0$	1,2	1,4	1,9	2,4	3	3,6	4,2	4,8	6	7,2	9,6	12
<i>d_s</i>	min.	0,86	1,06	1,46	1,86	2,36	2,86	3,32	3,82	4,82	5,82	7,78	9,78
	max.	1,00	1,20	1,60	2,00	2,50	3,00	3,50	4,00	5,00	6,00	8,00	10,00
<i>n</i>	nom.	0,2	0,25	0,3	0,3	0,4	0,5	0,5	0,6	0,8	1	1,2	1,6
	min.	0,26	0,31	0,36	0,36	0,46	0,56	0,56	0,66	0,86	1,06	1,26	1,66
	max.	0,40	0,45	0,50	0,50	0,60	0,70	0,70	0,80	1,00	1,20	1,51	1,91
<i>t</i>	min.	0,63	0,63	0,88	1,0	1,10	1,25	1,50	1,75	2,00	2,5	3,1	3,75
	max.	0,78	0,79	1,06	1,2	1,33	1,50	1,78	2,05	2,35	2,9	3,6	4,25
<i>x</i>	max.	0,6	0,6	0,9	1	1,1	1,25	1,5	1,75	2	2,5	3,2	3,8
<i>l_{b, c}</i>													
	nom. min. max.												
	2,5 2,3 2,7												
	3 2,8 3,2												
	4 3,7 4,3												
	5 4,7 5,3												
	6 5,7 6,3												
	8 7,7 8,3												
	10 9,7 10,3												
	12 11,6 12,4												
	(14) 13,6 14,4												
	16 15,6 16,4												
	20 19,6 20,4												
	25 24,6 25,4												
	30 29,6 30,4												
	35 34,5 35,5												
^a <i>P</i> is the pitch of the thread.													
^b The range of commercial length is between the bold stepped lines.													
^c Sizes in brackets should be avoided if possible.													

4 Specifications and reference International Standards

See Table 2.

Table 2 — Specifications and reference International Standards

Material		Steel	Stainless steel	Non-ferrous metal
General requirements	International Standard	ISO 8992		
	Tolerance	6g		
Thread	International Standards	ISO 261, ISO 965-2		
	Property class	14H, 22H, 45H	A1-12H	As agreed
Mechanical properties	International Standards	ISO 898-5	ISO 3506-3	ISO 8839
	Product grade	A		
Tolerances	International Standard	ISO 4759-1		
	Finish	As processed Requirements for electroplating are covered in ISO 4042. Requirements for non-electrolytically applied zinc flake coatings are covered in ISO 10683.	Plain	Plain Requirements for electroplating are covered in ISO 4042.
Surface discontinuities		Limits for surface discontinuities are covered in ISO 6157-1.		
Acceptability		The acceptance procedure is covered in ISO 3269.		

5 Designation

EXAMPLE A slotted headless screw with shank, thread M4, length $l = 10$ mm and with property class 14H, is designated as follows:

Headless screw ISO 2342 - M4 × 10 - 14H

1

ICS 21.060.10

Price based on 4 pages