**Fibre ropes — Determination of certain
physical and mechanical properties**

*Cordages en fibres — Détermination de certaines caractéristiques
physiques et mécaniques*



PDF disclaimer

This PDF file may contain embedded typefaces. In accordance with Adobe's licensing policy, this file may be printed or viewed but shall not be edited unless the typefaces which are embedded are licensed to and installed on the computer performing the editing. In downloading this file, parties accept therein the responsibility of not infringing Adobe's licensing policy. The ISO Central Secretariat accepts no liability in this area.

Adobe is a trademark of Adobe Systems Incorporated.

Details of the software products used to create this PDF file can be found in the General Info relative to the file; the PDF-creation parameters were optimized for printing. Every care has been taken to ensure that the file is suitable for use by ISO member bodies. In the unlikely event that a problem relating to it is found, please inform the Central Secretariat at the address given below.



COPYRIGHT PROTECTED DOCUMENT

© ISO 2010

All rights reserved. Unless otherwise specified, no part of this publication may be reproduced or utilized in any form or by any means, electronic or mechanical, including photocopying and microfilm, without permission in writing from either ISO at the address below or ISO's member body in the country of the requester.

ISO copyright office
Case postale 56 • CH-1211 Geneva 20
Tel. + 41 22 749 01 11
Fax + 41 22 749 09 47
E-mail copyright@iso.org
Web www.iso.org

Published in Switzerland

Contents

Page

Foreword	iv
1 Scope	1
2 Normative references	1
3 Terms and definitions	2
4 Principle.....	2
5 Apparatus	2
6 Sampling.....	3
7 Test pieces for tensile testing and force-elongation	3
8 Conditioning	4
9 Procedure	4
10 Expression of results	8
11 Test report.....	9
12 Determination of water repellency.....	9
13 Determination of lubrication and finish content	11
14 Determination of heat-setting on polyamide and polyester ropes.....	11
Annex A (normative) Reference tension to be applied to ropes when measuring linear density and lay length or braid pitch.....	12
Annex B (informative) Special procedure for determination of high breaking forces.....	13
Annex C (normative) Determination of the force-elongation coordinates on a “special” test piece.....	15
Bibliography.....	16

Foreword

ISO (the International Organization for Standardization) is a worldwide federation of national standards bodies (ISO member bodies). The work of preparing International Standards is normally carried out through ISO technical committees. Each member body interested in a subject for which a technical committee has been established has the right to be represented on that committee. International organizations, governmental and non-governmental, in liaison with ISO, also take part in the work. ISO collaborates closely with the International Electrotechnical Commission (IEC) on all matters of electrotechnical standardization.

International Standards are drafted in accordance with the rules given in the ISO/IEC Directives, Part 2.

The main task of technical committees is to prepare International Standards. Draft International Standards adopted by the technical committees are circulated to the member bodies for voting. Publication as an International Standard requires approval by at least 75 % of the member bodies casting a vote.

Attention is drawn to the possibility that some of the elements of this document may be the subject of patent rights. ISO shall not be held responsible for identifying any or all such patent rights.

ISO 2307 was prepared by Technical Committee ISO/TC 38, *Textiles*.

This fourth edition cancels and replaces the third edition (ISO 2307:2005), which has been technically revised.

Fibre ropes — Determination of certain physical and mechanical properties

1 Scope

This International Standard specifies, for ropes of different kinds, a method of determining each of the following characteristics:

- linear density;
- lay length;
- braid pitch;
- elongation;
- breaking force.

The linear density, lay length and braided pitch are measured with the rope under a specified tension called the reference tension, as specified in Annex A.

The elongation corresponds to the measured increase in length of the rope when the tension to which it is subjected is increased from an initial value (reference tension) to a value equal to 50 % of the minimum specified breaking strength of the rope.

The breaking force is the maximum force registered (or reached) during a breaking test on the test piece, carried out on a tensile testing machine with constant rate of traverse of the moving element. The breaking force values given in the tables of rope specifications are only valid when this type of testing machine is used.

When it is not possible to test the whole section of rope, the method described in Annex B can be used, subject to agreement between the parties involved.

This International Standard also provides a method for measuring water repellency, lubrication and finish content, and heat setting treatment, when requested by the customer.

2 Normative references

The following referenced documents are indispensable for the application of this document. For dated references, only the edition cited applies. For undated references, the latest edition of the referenced document (including any amendments) applies.

ISO 139, *Textiles — Standard atmospheres for conditioning and testing*

ISO 1968, *Fibre ropes and cordage — Vocabulary*

ISO 9554:2010, *Fibre ropes — General specifications*

3 Terms and definitions

For the purposes of this document, the terms and definitions given in ISO 1968 and the following apply.

3.1

unspliced breaking force

breaking force which is obtained by application of the method described in 9.7.2

3.2

spliced breaking force

breaking force which is obtained by application of the method described in 9.7.3

4 Principle

4.1 Calculation of the linear density

The linear density is obtained by measurement of the mass and the length, under a reference tension, of a conditioned test piece.

4.2 Measurement of the lay length and braid pitch

This measurement is taken at the time of application of the reference tension.

4.3 Measurement of the elongation of the rope

This measurement is taken by comparing the lengths of a section of the test piece that has been subjected successively to

- a) the reference tension, and
- b) a tension equal to 50 % of the minimum specified breaking force for the rope.

4.4 Measurement of the breaking force

This measurement is carried out by increasing the tension in 4.3 b) to the breaking point.

5 Apparatus

5.1 Tensile testing machine, accommodating the assumed breaking force of the rope, which allows a constant rate of traverse of the moving element, in accordance with 9.5, and measurement of the breaking force to an accuracy of ± 1 %.

Different types of tensile testing machines may be used:

- pulley-type grip ("*cors de chasse*" testing machine);
- testing machine with bollards for eye splices;
- wedge-grip testing machine.

In the case of a "*cors de chasse*" tensile testing machine, the diameter of the pulleys or catches holding down the test pieces shall be equal to at least 10 times that of the rope being tested.

In the case of a testing machine with bollards, the diameter of the bollards passing through the eye-spliced test pieces shall be at least twice the diameter of the rope being tested.

5.2 Balance, allowing measurement of mass to an accuracy of ± 1 %.

6 Sampling

6.1 Sample size

When specified by the purchaser, a lot sample for acceptance testing shall be taken at random in accordance with 6.4.

6.2 Sample unit

If required, test samples shall be taken from each shipping unit, in the lot in the number and the length required to perform the specified tests. The test samples shall be included in the delivered mass or length.

As an alternative, the manufacturer's production and inspection records may be used, if agreed upon between the purchaser and the manufacturer.

6.3 Composition of the batch to be sampled

Samples shall be taken from a homogeneous batch, i.e. consisting of ropes of the same size and same dimensions and which have been subject to the same series of manufacturing operations and the same control procedure.

6.4 Selection of samples

Take the number N_S of samples at random from the batch in accordance with Equation (1):

$$N_S = 0,4 \sqrt{N} \quad (1)$$

where N is the batch size, expressed as the number of 220 m coils.

When the calculated value of N_S is not a whole number, the number obtained shall be rounded to the nearest whole number.

EXAMPLE 27,5 and 30,35 are rounded to 28 and 30, respectively.

Where $N_S < 1$, take one sample length.

7 Test pieces for tensile testing and force-elongation

7.1 Length

The test piece shall be of adequate length to give an effective length, L_U (see 9.3), between terminations which is at least equal to that given in Table 1, when mounted on the tensile testing machine (see Figures 1, 2 and 3).

Table 1 — Effective lengths

Type of rope	Type of mounting device	Minimum effective length, L_U mm
Man-made fibre ropes, reference number ≤ 10	all types	400
Man-made fibre ropes, reference number > 10 and ≤ 20	“ <i>cors de chasse</i> ”	400
	bollard type	1 000
	wedge grip	—
Man-made fibre ropes, reference number > 20	bollard type	2 000 ^a
Natural fibre ropes	all types	2 000

^a If the lay length is greater than 360 mm, L_U shall be increased to 5 lay lengths, if possible.

7.2 Number of test pieces

Take one test piece from each sample.

7.3 Taking the test pieces

Take the test piece either from one end of the samples, or from the body of the samples if they are intended to be cut. Take all necessary steps to prevent unlaying. If necessary, remove slightly unlaidd ends.

8 Conditioning

Ropes shall be tested in the ambient atmosphere, except in cases of dispute, when the test piece shall be placed in the atmosphere specified in ISO 139 for at least 48 h, immediately prior to testing.

9 Procedure

9.1 General

For the measurement of force-elongation and breaking force, perform the procedures specified in 9.2 to 9.7 sequentially.

For the linear density, perform the procedures specified in 9.8.

9.2 Initial measurements

Lay the test piece out straight on a flat surface by pressing with a slight force of the hand (not exceeding 20 % of the reference tension) (see Annex A).

Make two “w” marks on the test piece, spaced symmetrically with regard to its mid-point, and at a distance apart of l_0 that is greater than 400 mm.

In exceptional circumstances, when $L_U < 400$ mm, l_0 and l_2 (see 9.4) are measured on a separate test piece, with a minimum length of 400 mm, following the same procedure; the value l_2 is obtained by applying the appropriate tension by means of weights and a pulley.

9.3 Mounting the test piece on the testing machine

Fix the ends of the test piece onto the machine, in order to obtain the effective length of the test piece specified in 7.1.

In the case of a test on splices, the eyes shall have a minimum internal length of 6 times the rope diameter when closed; their production is left to the manufacturer's discretion.

In the case of man-made fibre ropes, it is recommended that the ends of the splices be tapered to finish.

Outside the segment l_0 , make two "r" marks on the test piece, delimiting the section in which a rupture is considered as normal, as shown in Figures 1 to 3.

The distance from each mark "r" to the end of the splice (or to the tangent point in the case of a "cors de chasse") shall be a minimum of twice the diameter and a maximum of three times the diameter of the rope.

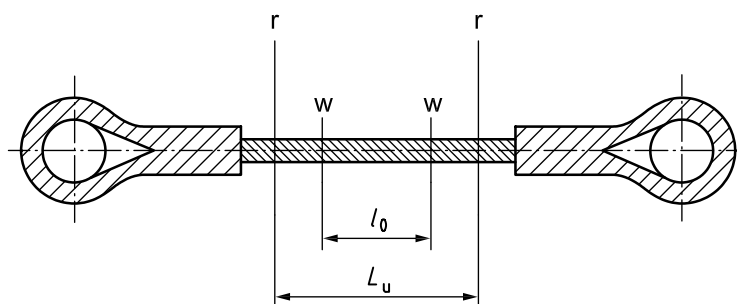

Key

- r limiting marks for the standard test
- L_u effective length measured with no tension
- w limiting marks for l_0

Figure 1 — Effective length, L_u , for testing machines with bollards for eye splices applied to ropes of reference number 20 and above

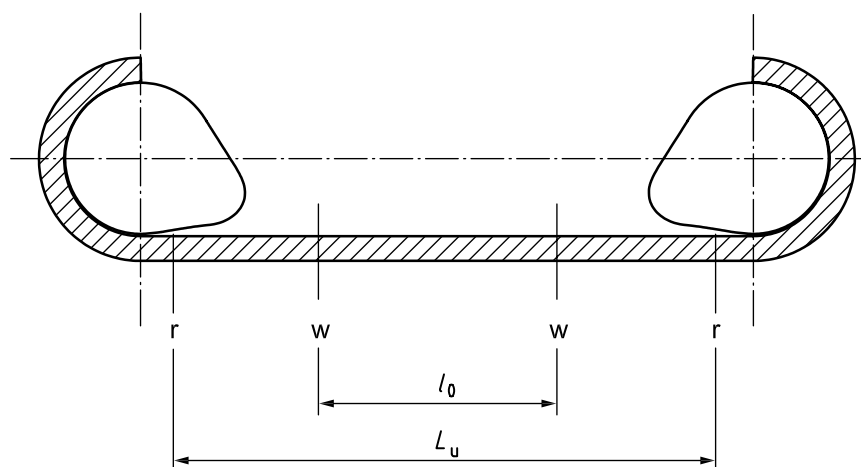

Key

- r limiting marks for the standard test
- L_u effective length measured with no tension
- w limiting marks for l_0

Figure 2 — Effective length, L_u , for pulley-type grips ("cors de chasse") testing machine applied to ropes of reference number < 20

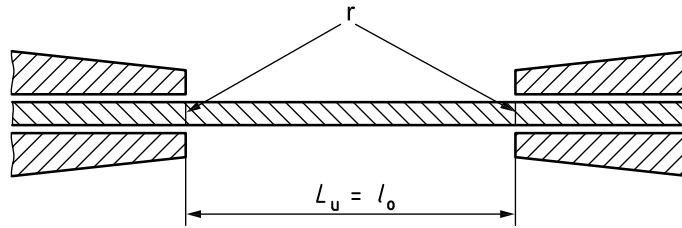

Key

- r limiting marks for the standard test
- L_u effective length measured with no tension

Figure 3 — Effective length, L_u , for wedge-grip testing machine applied to ropes of reference number < 20

9.4 Measurement of lay and gauge length

Apply the reference tension specified for the type of rope being tested (refer to Annex A) to the test piece and measure the following:

- a) the length of the maximum number of lays possible within L_u , expressed in millimetres;

NOTE The length of lay for laid ropes, and plait pitch for 8- and 12-strand ropes, are shown in Figures 4, 5 and 6, respectively.

- b) the distance between the two “w” marks. Let this distance be l_2 , the gauge length, expressed in millimetres, under the reference tension.

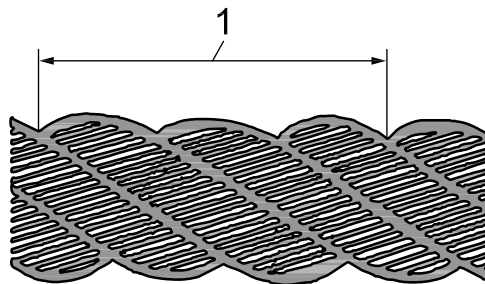

Key

- 1 one lay of a 3-strand rope

NOTE This also applies to 4- and 6-strand ropes, and this figure showing one lay of a 3-strand rope is provided as an example.

Figure 4 — Length of lay for 3-, 4- and 6-strand ropes

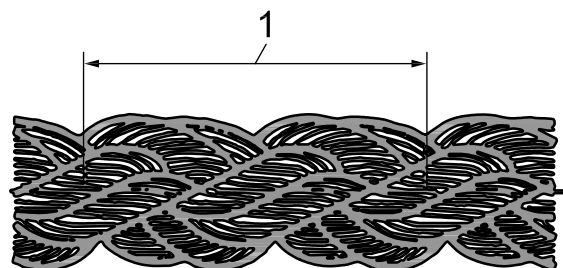

Key

- 1 one-plait pitch

Figure 5 — Plait pitch for 8-strand braided rope

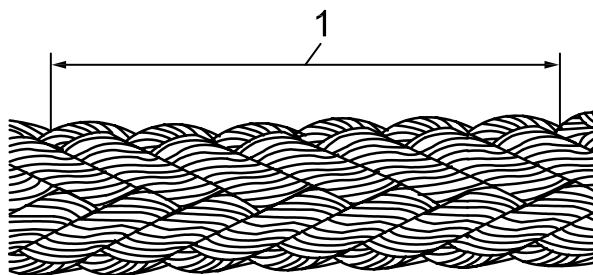
**Key**

1 one-plait pitch

Figure 6 — Plait pitch for 12-strand braided rope**9.5 Bedding-in of the test piece**

Before testing to the breaking point, subject the sample three times to a cyclic load between the reference tension and 50 % of the minimum breaking force of the rope. The test speed is (250 ± 50) mm/min, unless otherwise specified in a specific rope standard.

9.6 Measurement of the elongation of the rope

Increase the tension again by moving the moving element of the testing machine. The test shall be carried out at a speed of (250 ± 50) mm/min, unless otherwise specified in a specific rope standard.

When the tensile force reaches 50 % of the minimum breaking force, measure the distance between the “w” marks (the stoppage necessary for measurement shall be as brief as possible). Designate this distance as l_3 , the gauge length, expressed in millimetres, for a tensile force equal to 50 % of the specified minimum breaking force.

By previous agreement between the purchaser and supplier, a force-elongation curve, recorded during the tensile tests up to 50 % of the minimum breaking force of the rope, may be supplied.

It may be requested that the elongation be determined on a particular test piece. In this case, the procedure given in Annex C shall be followed to obtain the force-elongation coordinates.

9.7 Measurement of the breaking force

9.7.1 Continue to increase the tension, at the same speed, until a strand breaks.

Record the breaking force and the place on the test piece where the break occurs.

9.7.2 If an unspliced breaking force is specified, the specimen shall be deemed to meet the requirement if the break occurs:

- a) within the “r” marks and at a force equal to or higher than the specified value, or
- b) outside the “r” marks and at a force equal to or higher than 90 % of the specified value.

In the latter case, it should not be assumed that the true breaking force of the specimen would be represented by multiplying the result by 10/9.

9.7.3 If a spliced minimum breaking force is specified, the specimen shall be deemed to meet the requirement if it breaks at a force equal to or higher than the value for ropes with eye-spliced terminations, as indicated in the relevant standard.

9.8 Linear density

Take a new sample by drawing a length of rope of 2 m or more plus the length required for tensioning from the reel or coil and lay it out in a straight line on a flat surface. Tension the test length to the value required and maintain the tension for 1 min. Place two marks on the rope 2 m apart, then remove the tension and detach the sample from the parent length by cutting cleanly at the two marks. Determine the mass, m , of the test piece and calculate the mass per metre from the result.

NOTE This process can be assisted by lapping the rope with adhesive tape at the approximate position of the marks and then placing the marks on top of this tape whilst the rope is under tension. The tape will hold the rope together when it is subsequently cut at these marks and will assist in the presentation of a cleanly cut specimen.

10 Expression of results

10.1 General

For the linear density, lay length or braid pitch, and elongation (see 10.2 to 10.4), the numerical result of a test is the arithmetic mean of the individual values obtained on each test piece in the batch. As far as the tensile strength is concerned, the result is expressed by giving the breaking force (see 10.5) for each of the test pieces in the batch, without calculating the mean value.

The individual values are obtained as given in 10.2 to 10.5.

10.2 Linear density, ρ_1

The linear density (net mass, in grams per unit length), expressed in kilotex, is given by Equation (2):

$$\rho_1 = \frac{m}{l_1} \quad (2)$$

where

m is the mass, in grams, of the test piece;

l_1 is the measured length, in metres, of the test piece under the reference tension.

10.3 Lay length or braid pitch

The lay, l_p , expressed in millimetres, is given by Equation (3):

$$l_p = \frac{l_n}{n} \quad (3)$$

where l_n is the length of n complete turns of the same strand or, in the case of plaited ropes, the length between n successive plait points (see 9.4).

10.4 Elongation

The value of the elongation, E , expressed as a percentage, is given by Equation (4):

$$E = \frac{(l_3 - l_2) \times 100}{l_2} \quad (4)$$

where

l_2 is the gauge length, expressed in millimetres, under the reference tension (see 9.4);

l_3 is the gauge length, expressed in millimetres, for a tensile force equal to 50 % of the specified minimum breaking force (see 9.6).

10.5 Actual breaking force

Express the breaking force in kilonewtons, indicating whether or not the reported breaking force is spliced or unspliced according to 9.7.

11 Test report

The test report shall contain the following information:

- a) a reference to this International Standard (i.e. ISO 2307:2010);
- b) results obtained, expressed in accordance with 10.1 to 10.5;
- c) individual values which were used to calculate the results [except for breaking force values, which will already have been given in b)];
- d) particular test conditions (conditioning of the test pieces, type of tensile testing machines used, procedure used for determination of elongation, use of the procedure described in Annex B, where applicable);
- e) details of procedures not stipulated in the method and incidents which are likely to have affected the results.

12 Determination of water repellency

The determination of water repellency applies to ropes made from natural fibres.

12.1 Principle

The increase in mass of the rope is determined after immersion in water for a given period.

12.2 Test pieces

12.2.1 General

Place two marks 450 mm apart on the length of rope, clear of its ends.

12.2.2 Whipping

Place a tight and secure whipping over each mark. The length of these whippings shall not exceed the values specified in Table 2.

Table 2 — Length of whipping

Reference number of rope	Maximum length of whipping
	mm
≤ 24	15
> 24 but ≤ 48	20
> 48	25

12.2.3 Cutting the samples

Detach the samples from the parent length by cutting cleanly across the rope with a sharp knife at right angles to its longitudinal axis at the seizings, so that a suitably seized sample is obtained.

12.2.4 Sealing

To prevent absorption by capillary action, seal the ends off so that the whipping is just covered.

A suitable sealing material is pitch with a small amount of tar added to prevent cracking. Any other suitable sealing material may be used.

12.3 Procedure

12.3.1 First weighing

Carefully weigh each specimen after whipping and sealing, and then place it in tap water at a temperature of (20 ± 2) °C, taking care that the specimen is fully submerged, if necessary by weighting down, to a depth of 150 mm.

Do not add water after the specimens have been submerged.

In order to avoid the variations in mass due to atmospheric conditions, carry out the weighing immediately before immersion. Do not carry out the test until at least 24 h after the completion of manufacture of the rope.

12.3.2 Second weighing

After a total immersion of 1 h, take the specimens out of the water and, before weighing, dry them in the following manner. Shake each specimen six times to remove the superfluous water and then roll the sample on blotting paper until no wetting of the paper is observed. Finally, draw the specimens three times through an absorbent cloth, such as towelling. Then weigh the specimens and resubmerge in the water.

12.3.3 Third weighing

After a further 5h immersion period (making a total of 6 h in all), dry the specimens as described in 12.3.4 and weigh them.

12.3.4 Drying the specimens

Thoroughly dry each specimen by gentle heating, if necessary. Take care that the sealing is not affected by the temperature, and that the temperature does not exceed 50 °C. Dry the specimens to a mass slightly less than that obtained at the first weighing, so that, after exposure for at least 4 h to normal room atmospheric conditions, the specimens shall return as nearly as possible to their original mass.

12.3.5 Fourth, fifth and sixth weighing

Repeat the procedure described in 12.3.1 to 12.3.4 using the same specimens.

12.4 Results of tests

Record the gain in mass in each of the specimens as a percentage of the original mass (first and fourth weighing), for the 1 h immersion (second and fifth weighing), and for the 6 h immersion (third and sixth weighing).

13 Determination of lubrication and finish content

The determination of lubrication and finish content applies to ropes made from natural fibres.

13.1 Reagents

In this test, use reagents of laboratory reagent quality or equivalent.

13.2 Preparation of samples

Unlay the rope into its component yarns. Select, at random, representative yarns from the unlayed rope. Form these into a hank weighing between 30 g and 50 g.

13.3 Determination of water content

13.3.1 Weigh the hank prepared in 13.2 to the nearest 10 mg. Designate this mass as m_1 .

13.3.2 Distil the water contained in the sample after the addition of a suitable quantity of petroleum ether, and condense it in a graduated receiver.

13.3.3 Continue the distillation until the condensate in the graduated receiver becomes constant. Measure the volume of water to the nearest 0,1 ml. Designate this volume as V .

13.4 Determination of lubrication and finish content

13.4.1 Transfer the hank of yarn into a Soxhlet apparatus, and reflux with petroleum ether (boiling range 60 °C to 80 °C) until the extraction medium flows off in a colourless form, or, if colourless impregnating agents are present, until a specimen taken from the extract evaporates without residue.

13.4.2 Remove the hank from the Soxhlet apparatus, and place it in an oven at a temperature of 120 °C until all the solvent has evaporated. Transfer the hank to a desiccator until it has cooled to room temperature.

13.4.3 Re-weigh the sample to the nearest 10 mg. Designate this mass as m_2 .

13.5 Calculation of lubrication and finish content

13.5.1 Calculate the percentage of lubrication or finish using Equation (5):

$$L = \frac{(m_1 - V) - m_2}{m_1 - V} \times 100 \quad (5)$$

13.5.2 Express the result to the nearest 1 %.

14 Determination of heat-setting on polyamide and polyester ropes

To determine whether polyamide and polyester ropes have been thermofixed in accordance with 4.3.1 of ISO 9554:2010, when the production process is unknown, the following test shall be carried out by a competent person.

Cut a sample from the rope with a length of more than 40 times the diameter. Hang the sample vertically. Open by hand the strands of the rope and the yarns of the strands over a length of 40 times the diameter. If the strands and the yarns remain in a helical shape while hanging vertically, the rope is deemed to have been thermofixed.

Annex A (normative)

Reference tension to be applied to ropes when measuring linear density and lay length or braid pitch

The reference tension, F_T , expressed in kilonewtons, applied to the specimen shall be calculated from Equation (A.1):

$$F_T = \frac{n_{\text{ref}}^2}{8} \times 0,01 \quad (\text{A.1})$$

where n_{ref} is the reference number, expressed in millimetres.

See Table A.1 for the calculated nominal values of the reference tension to be applied to the ropes and their tolerance, as a function of the reference number of the rope.

**Table A.1 — Reference tension to be applied to ropes when measuring linear density
and lay or pitch length**

Reference number	Reference tension to be applied to the ropes		Reference number	Reference tension to be applied to the ropes	
	Nominal value kN	Tolerance %		Nominal value kN	Tolerance %
4	0,020	±5	44	2,42	±5
4,5	0,025		48	2,88	
6	0,045		52	3,38	
8	0,080		56	3,92	
9	0,101		60	4,50	
10	0,125		64	5,12	
12	0,180		72	6,48	
14	0,245		80	8,00	
16	0,320		88	9,68	
18	0,405		96	11,5	
20	0,500		104	13,5	
22	0,605		112	15,7	
24	0,720		120	18,0	
26	0,845		128	20,5	
28	0,980		136	23,1	
30	1,13		144	25,9	
32	1,28		152	28,9	
36	1,62		160	32,0	
40	2,00		—	—	

Annex B (informative)

Special procedure for determination of high breaking forces

The factors quoted in Tables B.1 and B.2 relate to the materials and constructions as specified.

The method indicated below may be used to calculate the strength only of 3-, 4-, 8- and 12-strand ropes and double-braid construction ropes of reference ≥ 44 and made of a single material and of yarns with the same linear density without lubrication, only by agreement between the parties involved, and only on condition that, before determining the breaking force of the yarns, the rope fulfils the specified conditions in all other respects.

In order to obtain the rope yarns necessary for the test, untwist a sufficient length of rope, avoiding any rotation of the individual rope components (yarns, strands) above their own axes. In the case of 3- or 4-strand ropes, 15 yarns shall be tested, of which three shall be selected from the centre of the strands. In the case of 8-strand and 12-strand braided rope, eight yarns in the two directions of twist S and Z shall be tested (i.e. a total of 16 yarns). In the case of double-braid ropes, 15 yarns from core and 15 yarns from cover shall be tested.

The test speed shall be (250 ± 50) mm/min, unless otherwise specified in a specific rope standard.

The yarns selected shall be mounted in turn on the testing machine. During this process, the necessary steps shall be taken to prevent the yarns untwisting before testing.

The mean of the results thus obtained shall be used to determine the breaking force, F_C , or F_S , of the rope from which the yarns were taken, by applying Equation (B.1) or Equation (B.2)

$$F_C = F_y \times n \times f_r \quad \text{for unspliced ropes} \quad (\text{B.1})$$

$$F_S = F_y \times n \times f_r \times 0,9 \quad \text{for spliced ropes} \quad (\text{B.2})$$

where

F_y is the mean force of the yarns;

n is the number of yarns in the rope;

f_r is the realization factor (see Tables B.1 and B.2).

Table B.1 — Realization factors

Reference number	Realization factors, f_r^a , for					
	polyester	polyamide	polypropylene	mixed polyolefin (polypropylene/high density polyethylene, PP/hdPE)	manila (abaca), sisal or hemp	Polyethylene (high density polyethylene, hdPE)
44	0,499	0,613	0,829	0,684	0,598	0,694
48	0,495	0,605	0,820	0,674	0,597	0,688
52	0,492	0,597	0,811	0,663	0,593	0,684
56	0,488	0,591	0,803	0,652	0,590	0,681
60	0,486	0,585	0,795	0,640	0,588	0,677
64	0,484	0,579	0,787	0,640	0,586	0,673
72	0,478	0,569	0,775	0,631	0,580	0,667
80	0,474	0,560	0,764	0,627	0,577	0,661
88	0,470	0,552	0,757	0,621	0,573	0,656
96	0,467	0,544	0,745	0,615	0,569	0,650
104	0,463	0,538	0,739	0,599	—	—
112	0,460	0,532	0,732	0,596	—	—
120	0,457	0,526	0,725	0,596	—	—
128	0,455	0,521	0,718	0,596	—	—
136	0,452	0,517	0,714	0,595	—	—
144	0,451	0,512	0,707	0,594	—	—
160	0,446	0,507	0,702	0,586	—	—

^a The realization factors apply for 3-, 8- and 12-strand ropes. The realization factors for 4-strand ropes are 10 % lower.

Table B.2 — Realization factors for double-braid construction

Reference number	Realization factor, f_r , for	
	polyester	polyamide
48	0,580	0,790
56	0,580	0,690
64	0,570	0,660
80	0,570	0,650
88	0,560	0,620
greater than 88	0,560	0,610

Annex C (normative)

Determination of the force-elongation coordinates on a “special” test piece

If it is requested that this be determined, the following procedure shall be followed.

The “special” test piece for the force-elongation test shall be mounted on the testing machine and loaded 10 times to 50 % of the specified minimum breaking strength. The rate of loading and unloading shall be as defined in 9.5 and the time for which each load is maintained or completely removed shall be as short as possible.

After complete removal of the tenth load, a period of 1 h shall be allowed for the test piece to relax, after which the appropriate reference tension specified in Annex A shall be applied.

While the test piece is under this tension, a suitable distance shall be marked on the rope. Increase the tension, recording the force-elongation coordinates up to a tension of 50 % of the specified breaking strength.

At no point during this test shall the test piece be disturbed or taken out of the testing machine.

Bibliography

- [1] ISO 1140, *Fibre ropes — Polyamide — 3-, 4- and 8-strand ropes*
- [2] ISO 1141, *Fibre ropes — Polyester — 3-, 4- and 8-strand ropes*
- [3] ISO 1181, *Fibre ropes — Manila and sisal — 3-, 4- and 8-strand ropes*
- [4] ISO 1346, *Fibre ropes — Polypropylene split film, monofilament and multifilament (PP2) and polypropylene high tenacity multifilament (PP3) — 3-, 4- and 8-strand ropes*
- [5] ISO 1969, *Fibre ropes — Polyethylene — 3- and 4-strand ropes*
- [6] ISO 10325, *Fibre ropes — High modulus polyethylene — 8-strand braided ropes, 12-strand braided ropes and covered ropes*
- [7] ISO 10547, *Polyester fibre ropes — Double braid construction*
- [8] ISO 10554, *Polyamide fibre ropes — Double braid construction*
- [9] ISO 10556, *Fibre ropes of polyester/polyolefin dual fibres*
- [10] ISO 10572, *Mixed polyolefin fibre ropes*
- [11] EN 1261, *Fibre ropes for general service — Hemp*

