International Standard



2262

INTERNATIONAL ORGANIZATION FOR STANDARDIZATION • МЕЖДУНАРОДНАЯ ОРГАНИЗАЦИЯ ПО СТАНДАРТИЗАЦИИ • ORGANISATION INTERNATIONALE DE NORMALISATION

ANSI Internat Doc Sect

General purpose thimbles for use with steel wire ropes — Specification

Cosses d'usages courants destinées à être utilisées avec des câbles en acier — Spécifications

Second edition — 1984-07-15

UDC 667.72 : 621.885

Ref. No. ISO 2262-1984 (E)

Descriptors : lifting equipment, wire rope, rope thimbles, specifications, tests, performance tests.

Price based on 3 pages

Foreword

ISO (the International Organization for Standardization) is a worldwide federation of national standards bodies (ISO member bodies). The work of developing International Standards is carried out through ISO technical committees. Every member body interested in a subject for which a technical committee has been authorized has the right to be represented on that committee. International organizations, governmental and non-governmental, in liaison with ISO, also take part in the work.

Draft International Standards adopted by the technical committees are circulated to the member bodies for approval before their acceptance as International Standards by the ISO Council.

International Standard ISO 2262 was developed by Technical Committee ISO/TC 111, *Round steel link chains, lifting hooks and accessories*, and was circulated to the member bodies in March 1983.

It has been approved by the member bodies of the following countries:

Australia	India	Romania
Austria	Italy	South Africa, Rep. of
Belgium	Japan	Sweden
Canada	Norway	United Kingdom
Germany, F.R.	Poland	

The member body of the following country expressed disapproval of the document on technical grounds:

Netherlands

This second edition cancels and replaces the first edition (i.e. ISO 2262-1972).

General purpose thimbles for use with steel wire ropes — Specification

1 Scope and field of application

This International Standard specifies the requirements for general purpose thimbles suitable for use with steel wire ropes complying with ISO 2408, having a maximum tensile grade of 1 770 MPa(N/mm²), with diameters from 4 to 60 mm.

It does not apply to thimbles for use with fibre ropes.

Reeving thimbles and solid thimbles are not included.

2 References

ISO 630, *Structural steels*.

ISO 1461, *Metallic coatings — Hot dip galvanized coatings on fabricated ferrous products — Requirements*.

ISO 2408, *Steel wire ropes for general purposes — Characteristics*.¹⁾

ISO 6892, *Metallic materials — Tensile testing*.²⁾

3 Nominal size

The nominal size of a thimble is the nominal diameter of the rope for which it has been primarily designed. The range of sizes of thimbles covered by this International Standard is from 4 to 60 mm.

4 Dimensions

The dimensions of thimbles shall comply with the appropriate values given in the table.

5 Material

The material from which the thimbles are to be formed shall be a steel that complies with ISO 630 or equivalent; it shall have

the following mechanical properties when tested in accordance with ISO 6892:

- tensile strength: 360 to 520 MPa (N/mm²);
- elongation after fracture: 20 % min.

6 Galvanizing

Unless otherwise specified, thimbles shall be galvanized with a zinc coating of at least 120 g/m² in accordance with ISO 1461.

7 Workmanship and freedom from defects

Thimbles shall be neatly formed, and shall be free from any flaw, defect, sharp edges or roughness, which might damage the rope.

The joint formed at the point of the thimble shall not be welded. A small gap at the joint may be allowed after galvanizing.

The thimbles may either be pointed (see figure 1) or without points (see figure 2), at the option of the manufacturer, unless one or other type is specifically ordered by the purchaser.

8 Prototype test

8.1 Object

The prototype test is intended to demonstrate that the thimble specified by the manufacturer and having dimensions which meet the requirements of this International Standard can withstand the maximum loading conditions likely to be imposed upon it under normal conditions of use.

The purpose of this test is to prove the design, material and method of manufacture of the thimble. Any change in material specification, method of manufacture or critical dimensions outside the normal manufacturing tolerances shall require that the prototype test in 8.2 be undertaken on the modified thimble.

1) At present at the stage of draft. (Revision of ISO 2408-1973.)

2) At present at the stage of draft. (Revision of ISO 82-1974.)

8.2 Method of test

Two tests shall be carried out on each size of thimble, of each design, material and method of manufacture. The thimble shall be fitted to a rope of 6 × 36 construction with steel core, of 1 770 MPa (N/mm²) tensile grade and shall be axially loaded to 32 % of the MBL (minimum breaking load) of the rope as specified in ISO 2408.

NOTE — For thimbles of nominal size 4, 6 and 8 mm (see the table), a rope of 6 × 7 construction with steel core, of 1770 MPa (N/mm²) tensile grade shall be used.

The load shall be applied to the thimble through a pin with a diameter of 1,5 *d* (where *d* is the nominal diameter of the rope).

After release of the test load any permanent reduction of dimension *A* of the thimble shall not exceed 15 % of its original value.

8.3 Procedure for re-testing

If any one thimble of each size tested fails to pass the test, a further two thimbles of the same size, design, material and

method of manufacture shall be tested in accordance with 8.2. If these pass the test, the thimbles shall be deemed to have passed the prototype tests.

If one or both fail the re-test or if more than one thimble fails the original test, the thimbles shall be deemed to have failed the prototype test.

9 Test certificate

The manufacturer or supplier shall, if required, provide a certificate giving the following information:

- a) a reference to this International Standard;
- b) name and address of manufacturer;
- c) nominal size of thimble;
- d) a declaration that the thimbles are of the same design, material and method of manufacture as thimbles which have passed the prototype test specified in clause 8.

Table — Dimensions of steel rope thimbles

Dimensions in millimetres

Nominal size of thimble ¹⁾ (Nominal rope diameter, <i>d</i>)	<i>F</i> _{max} (1,15 <i>d</i>)	<i>F</i> _{min} (1,075 <i>d</i>)	<i>C</i> _{max} (1,75 <i>d</i>)	<i>A</i> _{min} (2,5 <i>d</i>)	<i>D</i> _{min} (4,5 <i>d</i>)	<i>G</i> _{min} (0,55 <i>d</i>)	<i>K</i> _{max} (0,7 <i>d</i>)
4	4,6	4,3	7,0	10	18	2,2	2,8
6	6,9	6,5	10,5	15	27	3,3	4,2
8	9,2	8,6	14,0	20	36	4,4	5,6
10	11,5	10,8	17,5	25	45	5,5	7,0
12	13,8	12,9	21,0	30	54	6,6	8,4
13	15,0	14,0	22,8	32,5	58,5	7,2	9,1
14	16,1	15,1	24,5	35	63	7,7	9,8
16	18,4	17,2	28,0	40	72	8,8	11,2
18	20,7	19,4	31,5	45	81	9,9	12,6
20	23,0	21,5	35,0	50	90	11,0	14,0
22	25,3	23,7	38,5	55	99	12,1	15,4
24	27,6	25,8	42,0	60	108	13,2	16,8
26	29,9	28,0	45,5	65	117	14,3	18,2
28	32,2	30,1	49,0	70	126	15,4	19,6
32	36,8	34,4	56,0	80	144	17,6	22,4
36	41,4	38,7	63,0	90	162	19,8	25,2
40	46,0	43,0	70,0	100	180	22,0	28,0
44	50,6	47,3	77,0	110	198	24,2	30,8
48	55,2	51,6	84,0	120	216	26,4	33,6
52	59,8	55,9	91,0	130	234	28,6	36,4
56	64,4	60,2	98,0	140	252	30,8	39,2
60	69,0	64,5	105,0	150	270	33,0	42,0

1) For intermediate sizes of wire ropes the next larger nominal size of the thimble shall be used.

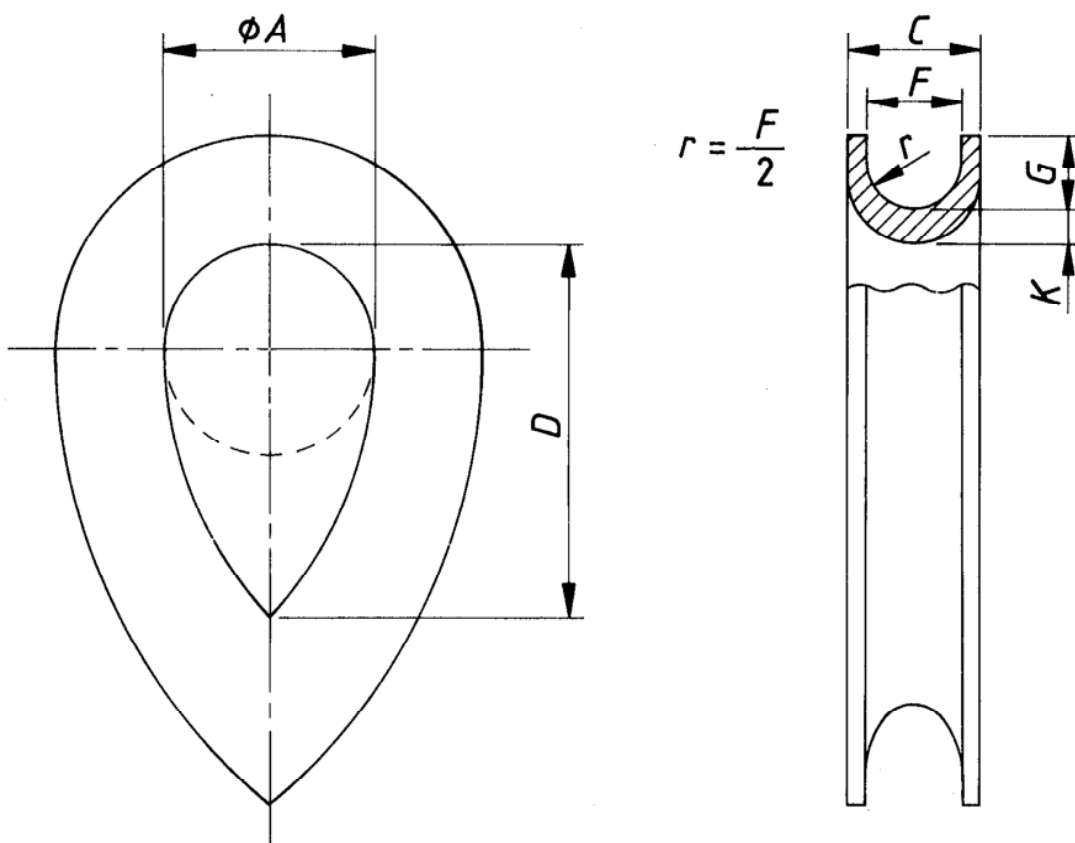

Figure 1 — Thimble with point

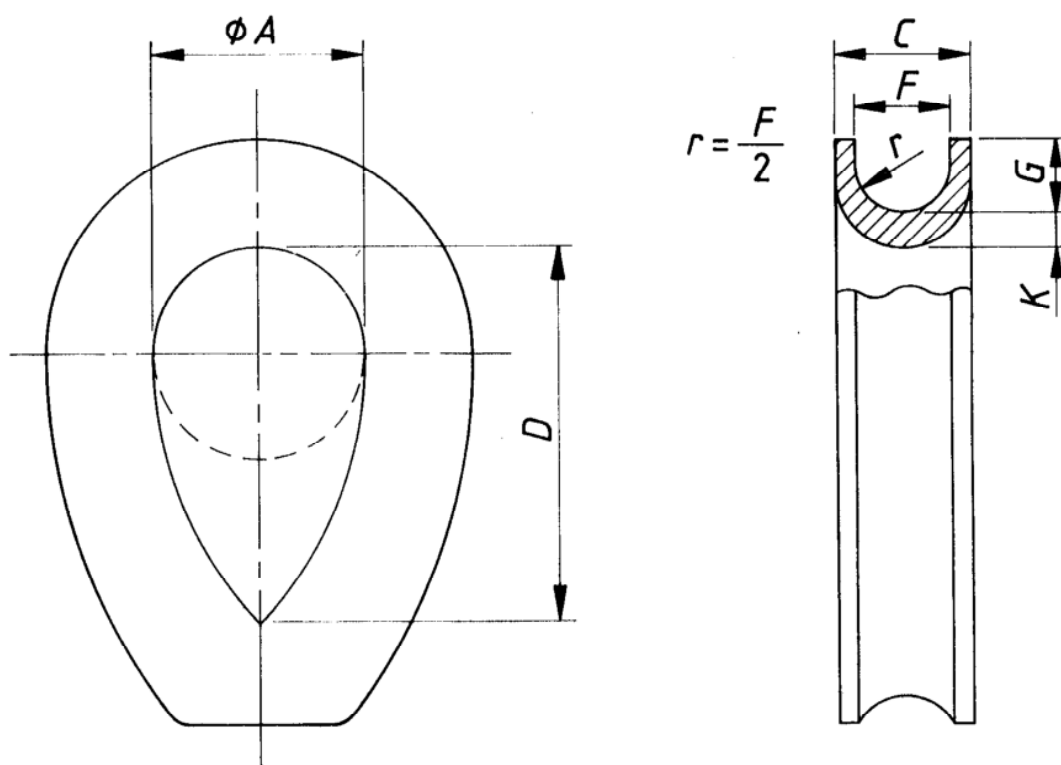

Figure 2 — Thimble without point

NOTE — These figures are only intended to illustrate where the dimensions specified in the table are measured. They are not intended to limit the detailed design of the thimble.