**Non-magnetic coatings on magnetic
substrates — Measurement of coating
thickness — Magnetic method**

*Revêtement métalliques non magnétiques sur métal de base
magnétique — Mesurage de l'épaisseur du revêtement — Méthode
magnétique*



COPYRIGHT PROTECTED DOCUMENT

© ISO 2016, Published in Switzerland

All rights reserved. Unless otherwise specified, no part of this publication may be reproduced or utilized otherwise in any form or by any means, electronic or mechanical, including photocopying, or posting on the internet or an intranet, without prior written permission. Permission can be requested from either ISO at the address below or ISO's member body in the country of the requester.

ISO copyright office
Ch. de Blandonnet 8 • CP 401
CH-1214 Vernier, Geneva, Switzerland
Tel. +41 22 749 01 11
Fax +41 22 749 09 47
copyright@iso.org
www.iso.org

Contents

Page

Foreword	v
1 Scope	1
2 Normative references	1
3 Terms and definitions	1
4 Principle of measurement	2
4.1 Basic principle of all magnetic measurement methods.....	2
4.2 Magnetic pull-off method.....	2
4.3 Magnetic inductive principle.....	3
4.4 Magnetic flux gauge.....	5
5 Factors affecting measurement accuracy	6
5.1 Basic influence of the coating thickness.....	6
5.2 Magnetic properties of the base metal.....	6
5.3 Electrical properties of the coating materials.....	7
5.4 Geometry: base metal thickness.....	7
5.5 Edge effect.....	7
5.6 Geometry: surface curvature.....	7
5.7 Surface roughness.....	8
5.8 Cleanliness: lift-off effect.....	8
5.9 Probe pressure.....	8
5.10 Probe tilt.....	8
5.11 Temperature effects.....	9
5.12 External electromagnetic fields.....	9
6 Calibration and adjustment of the instrument	9
6.1 General.....	9
6.2 Thickness reference standards.....	9
6.3 Methods of adjustment.....	10
7 Measurement procedure and evaluation	10
7.1 General.....	10
7.2 Number of measurements and evaluation.....	11
8 Uncertainty of the results	11
8.1 General remarks.....	11
8.2 Uncertainty of the calibration of the instrument.....	12
8.3 Stochastic errors.....	13
8.4 Uncertainties caused by factors summarized in Clause 5	13
8.5 Combined uncertainty, expanded uncertainty and final result.....	14
9 Precision	14
9.1 General.....	14
9.2 Repeatability (<i>r</i>).....	14
9.3 Reproducibility limit (<i>R</i>).....	15
10 Test report	15
Annex A (informative) Basic principle of all measurement methods	17
Annex B (informative) Basic performance requirements for coating thickness gauges which are based on the magnetic method described in this International Standard	19
Annex C (informative) Examples of experimental estimation of factors affecting the measurement	21
Annex D (informative) Example of uncertainty estimation (see Clause 8)	26
Annex E (informative) Basics of the determination of the uncertainty of a measurement of the used measurement method corresponding to ISO/IEC Guide 98-3	29

Annex F (informative) Table of the student factor	31
Annex G (informative) Details on precision	32
Bibliography	37

Foreword

ISO (the International Organization for Standardization) is a worldwide federation of national standards bodies (ISO member bodies). The work of preparing International Standards is normally carried out through ISO technical committees. Each member body interested in a subject for which a technical committee has been established has the right to be represented on that committee. International organizations, governmental and non-governmental, in liaison with ISO, also take part in the work. ISO collaborates closely with the International Electrotechnical Commission (IEC) on all matters of electrotechnical standardization.

The procedures used to develop this document and those intended for its further maintenance are described in the ISO/IEC Directives, Part 1. In particular the different approval criteria needed for the different types of ISO documents should be noted. This document was drafted in accordance with the editorial rules of the ISO/IEC Directives, Part 2 (see www.iso.org/directives).

Attention is drawn to the possibility that some of the elements of this document may be the subject of patent rights. ISO shall not be held responsible for identifying any or all such patent rights. Details of any patent rights identified during the development of the document will be in the Introduction and/or on the ISO list of patent declarations received (see www.iso.org/patents).

Any trade name used in this document is information given for the convenience of users and does not constitute an endorsement.

For an explanation on the meaning of ISO specific terms and expressions related to conformity assessment, as well as information about ISO's adherence to the WTO principles in the Technical Barriers to Trade (TBT) see the following URL: [Foreword - Supplementary information](#)

The committee responsible for this document is ISO/TC 107, *Metallic and other inorganic coatings*.

This third edition cancels and replaces the second edition (ISO 2178:1982), which has been technically revised.

Non-magnetic coatings on magnetic substrates — Measurement of coating thickness — Magnetic method

1 Scope

This International Standard specifies a method for non-destructive measurements of the thickness of non-magnetizable coatings on magnetizable base metals.

The measurements are tactile and non-destructive on typical coatings. The probe or an instrument with integrated probe is placed directly on the coating to be measured. The coating thickness is displayed on the instrument.

In this International Standard the term “coating” is used for material such as, for example, paints and varnishes, electroplated coatings, enamel coatings, plastic coatings, powder coatings, claddings.

NOTE This method can also be applied to the measurement of magnetizable coatings on non-magnetizable base metals or other materials (see ISO 2361).

2 Normative references

The following documents, in whole or in part, are normatively referenced in this document. For dated references, only the edition cited applies. For undated references, the latest edition of the referenced document (including any amendments) applies.

ISO 2064, *Metallic and other inorganic coatings — Definitions and conventions concerning the measurement of thickness*

ISO 4618, *Paints and varnishes — Terms and definitions*

ISO 5725-1:1994, *Accuracy (trueness and precision) of measurement methods and results — Part 1: General principles and definitions*

ISO/IEC Guide 98-3, *Uncertainty of measurement — Part 3: Guide to the expression of uncertainty in measurement (GUM:1995)*

3 Terms and definitions

For the purposes of this document, the terms and definitions given in ISO 2064 and ISO 4618 and the following apply.

3.1 adjustment of a measuring system

set of operations carried out on a measuring system so that it provides prescribed indications corresponding to given values of a quantity to be measured

Note 1 to entry: Adjustment of a measuring system can include zero adjustment, offset adjustment, and span adjustment (sometimes called gain adjustment).

Note 2 to entry: Adjustment of a measuring system should not be confused with calibration, which is a prerequisite for adjustment.

Note 3 to entry: After an adjustment of a measuring system, the measuring system shall usually be recalibrated.

Note 4 to entry: Colloquially the term “calibration” is frequently but falsely used instead of the term “adjustment”. In the same way, the terms “verification” and “checking” are often used instead of the correct term “calibration”.

[SOURCE: ISO/IEC Guide 99:2007, 3.11 (also known as “VIM”), modified – Note 4 to entry has been added.]

3.2

calibration

operation that, under specified conditions, in a first step, establishes a relation between the quantity values with measurement uncertainties provided by measurement standards and corresponding indications with associated measurement uncertainties and, in a second step, uses this information to establish a relation to obtain a measurement result from indication

Note 1 to entry: A calibration may be expressed by a statement, calibration function, calibration diagram, calibration curve, or calibration table. In some cases, it may consist of an additive or multiplicative correction of the indication with associated measurement uncertainty.

Note 2 to entry: Calibration should not be confused with adjustment of a measuring system, often mistakenly called “self-calibration”, nor with verification of calibration.

Note 3 to entry: Often, the first step alone in the above definition is perceived as being calibration.

[SOURCE: ISO/IEC Guide 99:2007, 2.39 (also known as “VIM”)]

4 Principle of measurement

4.1 Basic principle of all magnetic measurement methods

The magnetic flux density close to a magnetic field source (permanent magnet or electromagnet) depends on the distance to a magnetizable base metal. This phenomenon is used to determine the thickness of a non-magnetic coating applied to the base metal.

NOTE 1 [Annex A](#) describes the physical background of this effect in more detail.

All the methods covered by this International Standard evaluate the magnetic flux density to determine the thickness of the coating. The strength of the magnetic flux density is converted into corresponding electrical currents, electrical voltages or mechanical forces depending on the method used. The values are either pre-processed by digital means or are directly displayed on a usefully scaled gauge.

NOTE 2 The methods described in [4.3](#) and [4.4](#) can also be combined in one and the same probe with another method, e.g. with the eddy current method according to ISO 2360 or ISO 21968.

[Annex B](#) describes the basic performance requirements for coating thickness gauges based on the magnetic method described in this International Standard.

4.2 Magnetic pull-off method

The magnetic flux density of a permanent magnet and thus the attraction force between a permanent magnet and a magnetizable base metal decreases with increasing distance. In this way, the attraction force is a direct measure for the coating thickness of interest.

Instruments working with the magnetic pull-off method consist of at least three units:

- a permanent magnet;
- a pull-off device with continuously increasing pull-off force;
- a display or scale for the coating thickness, which is calculated from the pull-off force.

The pull-off force can be generated by different types of springs or an electromagnetic device.

Some instruments are able to compensate the influence of gravity and allow measurements in all positions.

All other instruments may only be used in the position specified by the manufacturer.

The location of measurement shall be clean and free from liquid or pasty coatings. The permanent magnet shall be free from particles.

Electrostatic charging can cause additional forces on the permanent magnet or the measuring system and is therefore to be avoided or shall be discharged before the measurement.

[Figure 1](#) shows a magnetic pull-off gauge.

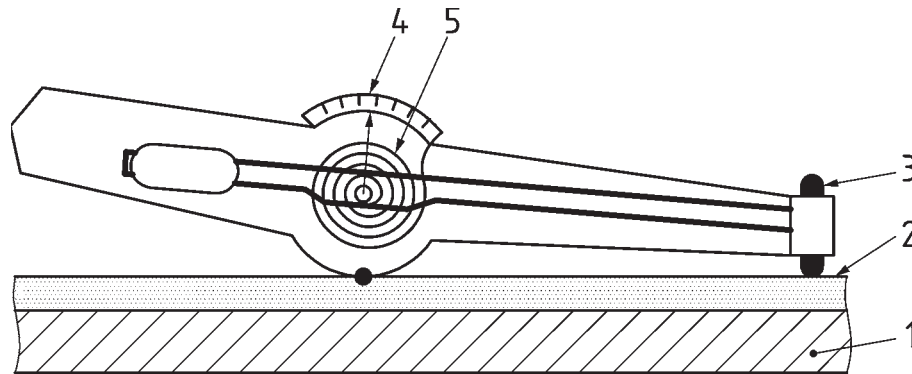

Key

- 1 base metal
- 2 coating
- 3 magnet
- 4 scale
- 5 spring

Figure 1 — Magnetic pull-off gauge

4.3 Magnetic inductive principle

The electrical inductivity of a coil changes when an iron core is inserted into the coil or when an iron object, e.g. a plate, approaches the coil. Therefore, the electrical inductivity can be used as a measure of the distance between the coil and a ferromagnetic substrate or as a measure of the coating thickness, if the coil is placed onto a coated magnetizable base metal.

There are many different electronic methods to evaluate changes of the electrical inductivity or the reaction of a coil system to a ferromagnetic substrate. Magnetic induction probes for thickness measurements of coatings on magnetizable materials can consist of one or more coils. Most often two coils are used (see [Figure 2](#)): the first (primary coil) to generate a low frequency alternating magnetic field and the second (secondary coil) to measure the resulting induced voltage U . If the probe is placed on a coated magnetizable material ($\mu_r > 1$) the magnetic flux density (see [Annex A](#)) and the induced voltage of the secondary coil vary as a function of the coating thickness. The function between the induced voltage and the coating thickness is nonlinear and depends on the permeability μ_r of the base metal. It is usually determined by a calibration. Calibration curves that assign a coating thickness to the induced voltages can be stored in the gauge.

Different designs and geometries of these kind of probes are used. Very often both coils are employed together with a highly magnetizable core in order to increase the sensitivity of the probes and to concentrate the field. In this way, both the coating area, which contributes to the thickness measurement, and the influence of the geometry of the coated component are reduced (see [5.5](#) and [5.6](#)).

On the contrary, a two pole probe (see [Figure 3](#)) has a wide and open field distribution. The two-pole probe has area integrating properties, while a one-pole probe measures locally.

Usually the frequency of the generated field is below the kilohertz range, which avoids eddy current generation if the coatings are conductive. Therefore, both conductive and nonconductive coatings can be measured by means of this principle.

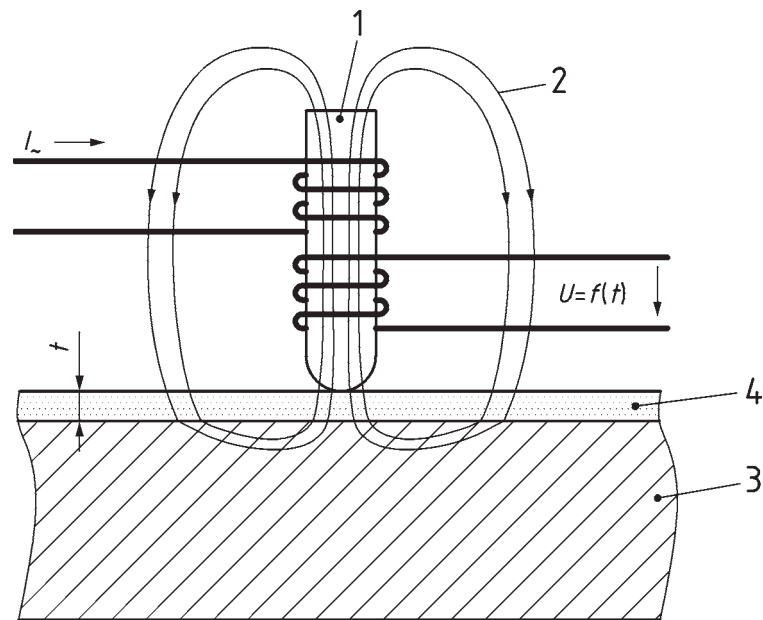

Key

- | | | | |
|---|--|------------|--------------------|
| 1 | iron core of the probe | I_{\sim} | exciting current |
| 2 | low frequency alternating magnetic field | t | coating thickness |
| 3 | steel/iron substrate | $U=f(t)$ | measurement signal |
| 4 | coating | | |

Figure 2 — Schematic of the magnetic induction principle

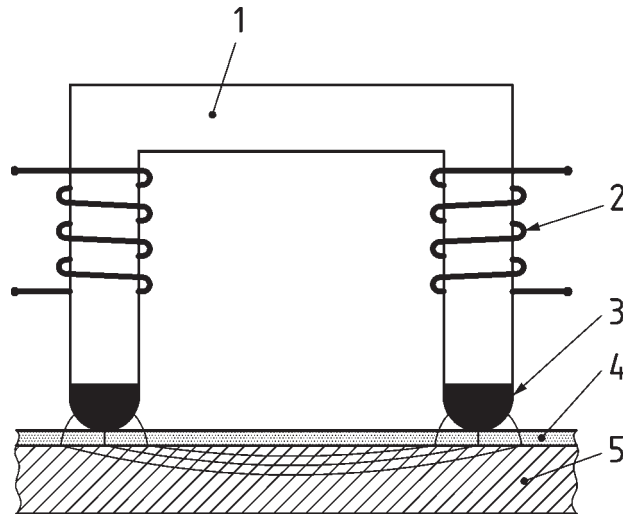
**Key**

1	iron core of the probe	4	coating
2	coil system	5	base metal
3	probe tip		

Figure 3 — Schematic of a two pole probe

4.4 Magnetic flux gauge

The magnetic flux density close to a magnet depends on the magnetic properties of the substances in the magnetic field. The magnetic flux density decreases if the fraction of non-magnetizable substances increases relative to magnetizable substances. This fact is used in magnetic flux gauges (see [Figure 4](#)). The coating (4) is non-magnetizable; the base metal (3) is magnetizable. A magnet (1) creates a magnetic field. Its field lines pass through both the coating and the base metal. A magnetic flux detector (5) placed close to the magnet outputs electrical signals, which depends on the coating thickness.

NOTE 1 Magnetic flux detectors are Hall-sensors or magneto resistive sensors.

NOTE 2 The magnet can be a permanent magnet or an electromagnet.

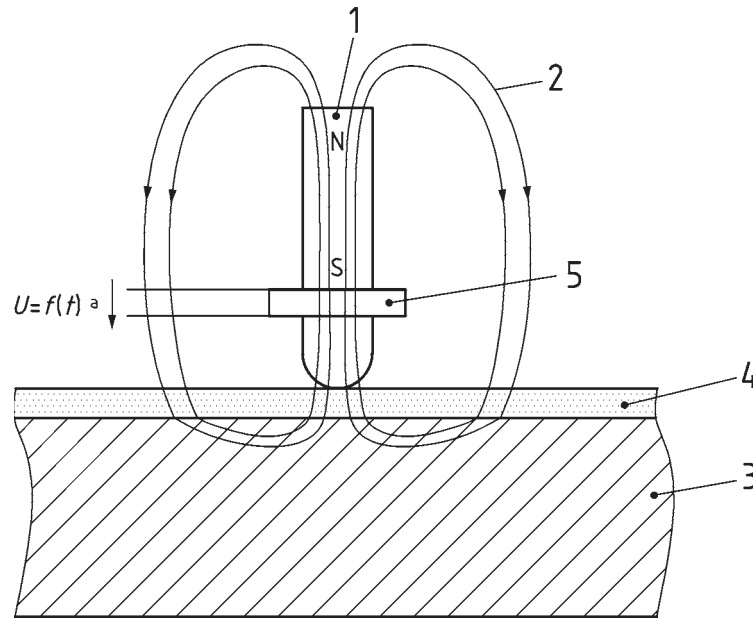

Key

- | | | | |
|---|--|-----|--------------------|
| 1 | permanent magnet | U | output voltage |
| 2 | static magnetic field | a | measurement signal |
| 3 | base metal | | |
| 4 | coating | | |
| 5 | Hall element as magnetic flux detector | | |

Figure 4 — Flux gauge using a Hall probe

The electric signals of the flux detector are further processed by electronic means. The function between flux detector output and the coating thickness is nonlinear and depends on the permeability μ_r of the base metal. It is usually determined by calibration. Calibration curves that assign a coating thickness to the electric detector output can be stored in the gauge.

5 Factors affecting measurement accuracy

5.1 Basic influence of the coating thickness

The sensitivity of a probe, i.e. the measurement effect, decreases with increasing thickness within the measurement range of the probe. In the lower measurement range this measurement uncertainty (in absolute terms) is constant, independent of the coating thickness. The absolute value of this uncertainty depends on the properties of the probe system and the used sample materials, e.g. the homogeneity of the base metal permeability, the base metal roughness and the sample surface roughness. In the upper measurement range of the probe the uncertainty becomes relative to the thickness and is approximately a constant fraction of that thickness.

5.2 Magnetic properties of the base metal

The permeability of the base metal causes the measurement effect of this method.

The relationship between coating thickness and the measured value depends strongly on the permeability of the base metal. Consequently, calibration procedures and measurements shall be made on the same material. Different materials with different permeabilities can cause more or fewer

thickness errors as well as local fluctuations of the permeability or variations between different samples.

Residual magnetism of the base material can also affect the measurements considerably, especially when static magnetic fields are used (see [4.2](#) for magnetic pull-off force or [4.4](#) for magnetic flux gauge).

The base metal can be magnetized by repeated measurements on the same location if a measurement method with a static magnetic field is used (see [4.2](#) for magnetic pull-off force or [4.4](#) for magnetic flux gauge). This may lead to errors in the thickness readings.

NOTE Examples of the initial permeability of typical steel used is in the range of 100 to 300.

5.3 Electrical properties of the coating materials

Coating thickness measurements can be affected if the probe is operated with an alternating magnetic field due to eddy currents (see [4.3](#) for magnetic inductive principle or [4.4](#) for magnetic flux gauge). These induced eddy currents can counteract the measurement effect of the magnetic method. The induced eddy current density increases with increasing conductivity and frequency.

NOTE Usually instruments using measurement methods [4.3](#) or [4.4](#) work within a frequency range below 1 kHz. Therefore, induced eddy currents affecting measurement results are only effective for thick coatings (thickness above 1 mm) with a high conductivity, e.g. copper.

5.4 Geometry: base metal thickness

If the base metal thickness is too small, the interaction of the magnetic field with the base metal is reduced. This influence can only be disregarded above a certain critical minimum base metal thickness.

Therefore, the thickness of the base metal should always be higher than this critical minimum base metal thickness. An adjustment of the instrument can compensate for errors caused by a too low base metal thickness. However, any variation in thickness of the base metal can cause increased uncertainty and errors.

The critical minimum base metal thickness depends on both the probe system (field strength, geometry) and the magnetic properties of the base metal. Its value should be determined experimentally, unless otherwise specified by the manufacturer.

NOTE A simple experiment to estimate the critical minimum base metal thickness is described in [C.2](#).

5.5 Edge effect

The expansion of the magnetic field is obstructed by geometric limitations of the base metal (e.g. edges, drills and other). Therefore, measurements made too near to an edge or corner cannot be valid unless the instrument has been specifically adjusted for such measurements. The necessary distance in order to avoid an impact of the edge effect depends on the probe system (field distribution).

NOTE A simple experiment to estimate the edge effect is described in [C.3](#).

5.6 Geometry: surface curvature

The propagation of the magnetic field is affected by the base metal surface curvature. This influence becomes more pronounced with decreasing radius of the curvature and decreasing coating thickness. In order to minimize this influence an adjustment should be performed on a base metal with the same geometry.

The influence of surface curvature depends considerably on the probe geometry and can be reduced by reducing the sensitive area of the probe. Probes with very small sensitive areas are often called microprobes.

Measurements performed on parts with too small radius of curvature can result in unreliable results, even after calibrations. The resulting uncertainty should be considered to determine whether such a measurement is acceptable or not.

NOTE A simple experiment to estimate the effect of surface curvature is described in [C.4](#).

5.7 Surface roughness

Measurements are influenced by the surface topography of the base material and of the coating. Rough surfaces can cause both systematic and random errors. Random errors can be reduced by making multiple measurements, each measurement being made at a different location, and then calculating the average value of that series of measurements.

In order to reduce the influence of roughness, a calibration should be carried out with an uncoated base metal with a roughness equivalent to the coated sample base metal.

If necessary, the definition of the used average coating thickness should be stated between supplier and client.

NOTE ISO 19840 describes special measurement procedures in cases of application paint and varnishes on steel with rough surfaces.

5.8 Cleanliness: lift-off effect

If the probe is not placed directly down on to the coating, the gap between probe and coating (lift-off) will act as an additional coating thickness and will therefore affect the measurement. Lift-off can be produced unintentionally due to the presence of small particles between probe and coating. The probe tip shall frequently be checked for cleanliness.

5.9 Probe pressure

The pressure that the probe exerts on the test specimen can affect the instrument reading and shall always be the same during adjustment and measurements.

The influence of the probe pressure is more pronounced in cases of soft coatings because the probe tip can be indented into the coating. Therefore, the probe pressure should be as small as possible. Most commercially available instruments are equipped with spring loaded probes, which ensure a constant pressure during the placement. A suitable auxiliary device should be used in case the probe is not spring loaded.

NOTE 1 The contact pressure and the probe tip indentation depth can be reduced by reducing the applied force or by using a probe with a larger diameter of the probe tip.

NOTE 2 An indentation of the probe tip into soft coatings can be reduced by placing a protective foil with known thickness onto the coated surface. In this case, the coating thickness is the measured thickness minus the foil thickness.

5.10 Probe tilt

Unless otherwise instructed by the manufacturer, the probe should be applied perpendicularly to the coating surface as tilting the probe away from the surface normal causes measurement errors.

The risk of inadvertent tilt can be minimized by probe design or by the use of a probe holding jig.

NOTE Most commercially available instruments are equipped with spring loaded probes, which ensure a perpendicular placement on the sample surface.

5.11 Temperature effects

As temperature changes affect the characteristics of the probe it should be used under approximately the same temperature conditions as under calibration.

NOTE 1 The influence of temperature variations can be reduced by a temperature compensation of the probe. The manufacturer's specification has to be taken into account.

NOTE 2 Temperature differences between probe, electronics of the instrument, environment and sample can cause strong thickness errors. One example is the thickness measurement of hot coatings.

5.12 External electromagnetic fields

The measurement results can be influenced by strong electromagnetic interfering fields. In cases showing unexpected results or a strong variation of results, which cannot be explained by other factors, this reason should be taken into account. In this situation, a comparison measurement should be carried out at a location without interfering fields.

6 Calibration and adjustment of the instrument

6.1 General

Before usage every instrument shall be calibrated or adjusted according to the instructions of the manufacturer by means of suitable thickness reference standards and base metal. Material, geometry and surface properties of the base metal used for calibration or adjustment should comply with the test specimens in order to avoid deviations caused by the factors described in [Clause 5](#). Otherwise these influences shall be considered in the estimation of the measurement uncertainty.

During calibration or adjustment the instruments, the standards and the base metal should have the same temperature as the test specimens to minimize temperature induced differences.

In order to avoid the influence of instrument drifts, periodic control measurements with reference standards or control samples are recommended. If required, the instrument has to be re-adjusted.

NOTE Most instruments automatically adjust themselves during a function called "calibration", carried out by the operator, whereas the result of the calibration is often not obvious.

6.2 Thickness reference standards

Thickness reference standards for calibration and adjustment are either coated base metals or foils, which are placed onto uncoated base metals.

Foils and coatings shall be non-magnetizable. Thickness values of the reference standards and their associated uncertainties shall be known and unambiguously documented. The surface area for which these values are valid shall be marked. The thickness values should be traceable to certified reference standards.

The uncertainties shall be documented with their confidence level, e.g. U (95 %), i.e. there is a 95 % probability that the documented thickness value is within the reported uncertainty interval.

Prior to use, foils and coatings are to be checked visually for damage or mechanical wear as this would cause a wrong adjustment and therefore systematic deviation of all measurement values.

The use of foils as reference standards, compared to selected coated base metals, will enable the foils to be placed directly on to the base metal, thus matching the shape and geometry exactly.

However, by placing the probe on foils elastic or plastic deformation may occur, which can affect the measuring result. Moreover, any gap between the pole of the probe, foil and base metal has to be avoided. Especially for concave specimens, or if the foil is wrinkled or bended, the usually low pressure of the spring loaded guiding sleeve of the probe may not be sufficient to ensure there is no gap.

A possible elastic or even plastic deformation of a reference foil used depends on the applied load force of the probe and the probe tip diameter (see 5.9). Consequently, the calibration of such reference foils should be carried out with comparable values of the applied force and tip diameter to avoid indentation differences during the probe calibration. In this way, respective indentation errors are already taken into account in the foil thickness value, i.e. this value can be smaller than the unaffected geometric thickness. Both values, the applied force and the tip diameter of the foil calibration should be known from the reference foil manufacturer in order to estimate possible thickness errors.

NOTE In most cases the foil material is plastics but other materials, e.g. copper alloys, can be used as well.

6.3 Methods of adjustment

Adjustment of the coating thickness gauges is executed by placing the probes on uncoated and/or one or more coated pieces of base metal with known coating thickness. Depending on the instrument types, the instructions of the manufacturer and the functional range of the instrument under use, adjustments can be carried out on the following items:

- a) a piece of uncoated base metal;
- b) a piece of uncoated base metal and a piece of coated base metal with defined coating thickness;
- c) a piece of uncoated base metal and several pieces of coated base metal with defined but different coating thickness;
- d) several pieces of coated base metal with defined but different coating thickness.

The stated adjustment methods may lead to different accuracies of the measuring results. Thus, a method should be used that best fits the given application and leads to the desired accuracy. The measuring uncertainty that can be achieved by the different adjustment methods depends on the evaluation algorithm of the gauges as well as on the material, geometry and surface condition of the standards and of the base metals to be measured. If the desired accuracy is not achieved by one method, a different adjustment method may lead to better results. In general, the measuring uncertainty can be reduced by increasing the number of adjustment points and positioning them with closer coverage over the expected thickness interval of the coating to be measured.

The measurement uncertainty resulting from an adjustment of the instrument cannot be generalized to all subsequent measurements. In each case, all specific and additional influencing factors need to be considered in detail, see [Clause 5](#) and [Annex C](#).

NOTE 1 The process that is used to adapt the probe to the given base metal by placing the probe onto the uncoated base metal is often called “zeroing” or “zero point calibration”. However, even this procedure is an “adjustment” or part of an adjustment process as defined by this International Standard.

NOTE 2 Depending on how many pieces of coated and uncoated base metals are used to adjust the instrument the corresponding adjustment method is often called “single-point”, “two-point” or “multiple-point adjustment”.

NOTE 3 Some types of gauges permit resetting the instrument to an original adjustment of the manufacturer. This adjustment is valid for the manufacturer’s uncoated or coated reference standards only. If these standards or the same types of standards are used to check the instrument after a period of use, any deterioration of gauge and probes, e.g. wear of the probe by abrasion of the contact pole, can be recognized by observing deviations of the measuring results.

7 Measurement procedure and evaluation

7.1 General

Every instrument shall be operated according to the manufacturer’s instructions and shall consider the factors affecting measurement accuracy discussed in [Clause 5](#).

Before using the instrument and after making changes affecting the measurement accuracy (see [Clause 5](#)) the adjustment of the instrument shall be checked.

To ensure that the instrument measures exactly it shall be calibrated with valid standards at the place of inspection each time

- a) the instrument is put into operation,
- b) the material and geometry of the test specimens are changed, or
- c) other conditions of the inspection have changed (e.g. temperature) whose effects are not known (see [Annex D](#)).

As not all changes of measurement conditions and their influences on the measurement accuracy can be immediately recognized (e.g. drift, wear of the probe) the instrument should be calibrated at regular time intervals while in use.

7.2 Number of measurements and evaluation

The coating thickness should be determined as the arithmetic mean of several single values, which are measured in a defined area of the coating surface. In addition to the mean, the standard deviation should be reported (see [Annex E](#)). The random part of the measurement uncertainty can be reduced by increasing the number of measurements. If not otherwise specified or agreed upon, it is recommended to measure at least five single values (depending on the application).

NOTE 1 From the standard deviation a variation coefficient V can be calculated. V corresponds to the relative standard deviation (e.g. in percent) and enables a direct comparison of the standard deviation for different thicknesses.

NOTE 2 The total scatter of the measurement is composed of the scatter of the instrument itself and the scatter caused by the test specimen. The standard deviation of operator and probe in the measured thickness range is determined by repeated measurements at the same location, if required with the help of an auxiliary device for placing the probe.

NOTE 3 When measuring on rough coating surfaces or on test specimens with known large thickness gradients (e.g. due to their size and/or their shape) the reason for deviations between the single measurements can be determined by a series of systematic measurements.

8 Uncertainty of the results

8.1 General remarks

A complete evaluation of the uncertainty of the measured thickness shall be carried out in accordance with ISO/IEC Guide 98-3. Details of the background of the expression of the uncertainty are summarized in [Annex E](#).

Uncertainty of the thickness measuring result is a combination of uncertainties from a number of different sources. Important sources that should be considered include the following:

- a) uncertainty of the calibration of the instrument;
- b) stochastic influences affecting the measurement;
- c) uncertainties caused by factors summarized in [Clause 5](#);
- d) further influences, drifts, digitalization effects and other effects.

All uncertainty components shall be estimated and summarized to the combined standard uncertainty as described in ISO/IEC Guide 98-3, see [Annex E](#).

A possible procedure for the estimation of the uncertainty is given in the following simplified approach (see 8.2 to 8.5).

NOTE 1 The single uncertainty components of the listed sources are dependent on the respective measurements, the properties of the samples measured, the instrument, the environmental condition, etc. and can show large differences for different applications. Therefore, the single uncertainty components are estimated for each measurement in detail. The quality of the uncertainty is determined by the quality of the estimation of all uncertainty components. Missing components result in wrong uncertainty estimations and consequently in wrong thickness results.

NOTE 2 In particular, the factors listed in Clause 5 can result in large uncertainty values and are minimized by an adjustment if possible.

NOTE 3 In addition to the need to express the uncertainty in the result, the analysis of possible uncertainty components provides detailed information in order to improve the measurement.

8.2 Uncertainty of the calibration of the instrument

If no other information is given, the current uncertainty of an instrument can be estimated within a limited thickness range by realization of n repeated measurements on a given reference standard with known thickness t_r and uncertainty $U_r(k = 2)$. The measurement result is the arithmetic mean value \bar{t}_m of the measured thickness values with the standard deviation $s(t_m)$. The quality of the calibration is determined by the ratio E of the resulting difference $|\bar{t}_m - t_r|$ and the combined uncertainty of the verification measurement. This uncertainty (denominator of E , $k = 2$) is considered to be caused by the stochastic error of the measurement with n repeats (compare 8.3) and the given reference standard uncertainty U_r . In the case of $E \leq 1$ the calibration is valid and cannot be further improved by means of this reference standard, i.e. the difference cannot be distinguished from the uncertainty. Therefore, the standard uncertainty of the calibration u_{cal} ($k = 1$) is given by the combined uncertainty of the verification measurement but with respect to the 1 sigma level ($k = 1$).

However, in the case of $E > 1$ a significant deviation of the calibration within the uncertainty is detected and an adjustment of the instrument should be carried out in order to improve the calibration accuracy.

$$E = \frac{|\bar{t}_m - t_r|}{2 \cdot u_{cal}} \tag{1}$$

$$u_{cal} = \sqrt{\left[t(68,27\%, n - 1) \cdot \frac{s(t_m)}{\sqrt{n}} \right]^2 + [0,5 \cdot U_r]^2} \tag{2}$$

NOTE 1 In case the tolerance T of the reference standard is given ($t_r \pm T$) instead of U_r the respective uncertainty $U_r(k = 2)$ can be calculated: $U_r(k = 2) = 1,653 \cdot \frac{T}{\sqrt{3}}$.

The calibration uncertainty u_{cal} is only valid in a small thickness range around t_r . In the case of a larger thickness range of interest, the uncertainty u_{cal} should be estimated on both sides of the thickness range. The linear interpolation between both values gives the uncertainty of interest as a function of the thickness.

Very often the accuracy of the calibration is limited by the given uncertainty of the reference standard, as the uncertainty of the calibration cannot be smaller than the uncertainty of the reference standard used. In order to improve the calibration, a reference standard with a smaller uncertainty is necessary.

Usually a normalization or zeroing on an uncoated base metal is recommended by the manufacturer at the beginning of a measurement. The resulting uncertainty of this normalization is considered to be already included in u_{cal} .

NOTE 2 $t(68,27\%, n-1)$: student factor (degrees of freedom $f = n - 1$ and level of confidence with $p = 68,27\%$). Respective values are summarized in [Annex F](#).

8.3 Stochastic errors

General repeated measurements are recommended in order to improve the accuracy of the arithmetic mean value \bar{t} of the thickness values measured (see [7.2](#)), i.e. to reduce the uncertainty of the thickness result. In the case of n repeated measurements, the standard uncertainty u_{sto} ($k = 1$) of the arithmetic mean \bar{t} can be estimated by (Type A):

$$u_{\text{sto}} = t(68,27\%, n-1) \cdot \frac{s(\bar{t})}{\sqrt{n}} \quad (3)$$

The standard uncertainty u_{sto} is a measure of all errors arising from unpredictable or stochastic temporal and spatial variations of influence quantities.

u_{sto} is calculated both for calibration uncertainty and uncertainty of the thickness measurement of a sample.

The standard uncertainty u_{sto} can be reduced by increasing the number of repeated measurements. This can be important, e.g. in the case of rough sample surfaces.

Care should be taken to address the risk that Type B standard uncertainties (e.g. see [8.4](#)), which might contribute to Type A standard uncertainties, are not counted twice.

NOTE Not all contributions to the uncertainty u_{sto} are of a random nature (Type A). This depends on the design of experiment. For example, the measured thickness of a larger sample with a thickness gradient results in a high uncertainty u_{sto} because of the systematic thickness variation. In the case of a reduced measurement area u_{sto} is reduced and the arithmetic mean value \bar{t} gives a better description of the local thickness.

8.4 Uncertainties caused by factors summarized in [Clause 5](#)

The influence of the factors summarized in [Clause 5](#) should be minimized by means of a calibration whenever this is possible. However, very often these influences can only be estimated and the resulting uncertainty shall be considered as a component of the combined uncertainty of the measurement. Simple experiments to estimate the uncertainty of some of these factors are described in [Annex C](#). Usually the influence of these factors, and therefore the resulting uncertainties, are a function of thickness. Consequently, in order to estimate the uncertainty for a given thickness or for, at least, a small thickness range the experiments shall be carried out with samples with the thickness of interest.

For example, the variation of the magnetic properties of the base metal is considered (permeability variation). As described in [C.5](#), the expected variation should be estimated for the thickness of interest. The resulting thickness variation with respect to the selected reference base metal should be $\Delta t_{\text{bm}} = \text{abs}(t_{\text{min}} - t_r)$ or $\text{abs}(t_{\text{max}} - t_r)$. This gives the standard uncertainty caused by the variation of the base metal properties $u_{\text{bm}}(k = 1)$:

$$u_{\text{bm}} = \frac{\Delta t_{\text{bm}}}{\sqrt{3}} \quad (4)$$

The same estimation of the standard uncertainty shall be carried out for all relevant factors listed in [Clause 5](#). For example, in the case of an expected variation of the surface curvature resulting in Δt_{cs} with respect to the procedure [C.4](#), the standard uncertainty can be estimated as $u_{\text{cs}}(k = 1)$:

$$u_{\text{cs}} = \frac{\Delta t_{\text{cs}}}{\sqrt{3}} \quad (5)$$

In case the influence of a factor is minimized by a calibration the remaining uncertainty of this calibration shall be considered.

Some of the factors influencing the accuracy, e.g. base metal properties ([5.4](#)) or surface curvature ([5.6](#)), can be minimized by means of flexible foils as reference standards, if the calibration is carried out with foils on the base metal with identical material and curvature properties as the sample of interest. In this case only expected variations of the sample properties shall be considered.

8.5 Combined uncertainty, expanded uncertainty and final result

The combined uncertainty summarizes all the standard uncertainty components ([8.2](#), [8.3](#), [8.4](#) and any potential others). In the simplified approach described, when estimating the uncertainties for a given thickness, or for a very small thickness range, the sensitivity coefficients can be considered to be equal to 1 (see [Annex E](#)). This results in the combined uncertainty u_c :

$$u_c = \sqrt{u_{\text{cal}}^2 + u_{\text{sto}}^2 + u_{\text{bm}}^2 + u_{\text{cs}}^2 + \dots} \quad (6)$$

As the final result, the expanded uncertainty $U(k = 2)$ is calculated (2-sigma level, 95,45 %):

$$U(k = 2) = 2u_c \quad (7)$$

And the complete result of the measurement with the thickness value \bar{t} :

$$t = \bar{t} \pm U(k = 2) \quad (8)$$

9 Precision

9.1 General

See [Annex G](#) for further information on determining precision.

9.2 Repeatability (r)

Repeatability, r , is the value less than or equal to which the absolute difference between two test results obtained under repeatability conditions may be expected to be, with a probability of 95 % (according to ISO 5725-1:1994, 3.16). The repeatability limit, r , in accordance with this International Standard and calculated with a probability of 95 %, is given in [Table 1](#).

Table 1 — Repeatability limit (r)

Coating thickness	r_{x_1}	$r_{\bar{x}}$
approx. μm	μm	μm
12	1,5	2,0
25	1,3	1,7
125	2,0	7,0
r_{x_1} Repeatability limit of first measuring point (triple measurement). $r_{\bar{x}}$ Repeatability limit of all five measuring points.		

9.3 Reproducibility limit (R)

Reproducibility limit, R , is the value less than or equal to which the absolute difference between two test results obtained under reproducibility conditions may be expected to be, with a probability of 95 % (according to ISO 5725-1:1994, 3.20). The reproducibility limit, R , in accordance with this International Standard and calculated with a probability of 95 %, is given in [Table 2](#).

Table 2 — Reproducibility limit (R)

Coating thickness	R_{x_1}	$R_{\bar{x}}$
approx. μm	μm	μm
12	4,2	4,3
25	6,0	6,0
125	5,8	8,7
R_{x_1} Reproducibility limit of first measuring point (triple measurement). $R_{\bar{x}}$ Reproducibility limit of all five measuring points.		

10 Test report

The test report shall include the following information:

- all information necessary for the identification of the test specimen;
- a reference to this International Standard, including its year of publication, i.e. ISO 2178:2016;
- the sizes of the test areas over which the measurements were made in square millimetres (mm^2);
NOTE Other units of measurement can be used, with agreement between supplier and client.
- the location(s) of the test area(s) on each specimen;
- the number of test specimens measured;
- an identification of the instrument, probe and standards used for the test, including reference to any validation certification of the equipment;
- the results of the test, reported as the measured thicknesses, in micrometres, at each area at which the test was carried out, including the results of the individual determinations, their arithmetic mean and the respective uncertainty;
- the name of the operator and testing organization;

ISO 2178:2016(E)

- i) any unusual features (anomalies) observed and any circumstances or conditions thought likely to affect the results or their validity;
- j) any deviation from the method specified;
- k) date of the test.

Annex A (informative)

Basic principle of all measurement methods

[Figure A.1](#) shows a ferrous ring coil with a small gap.

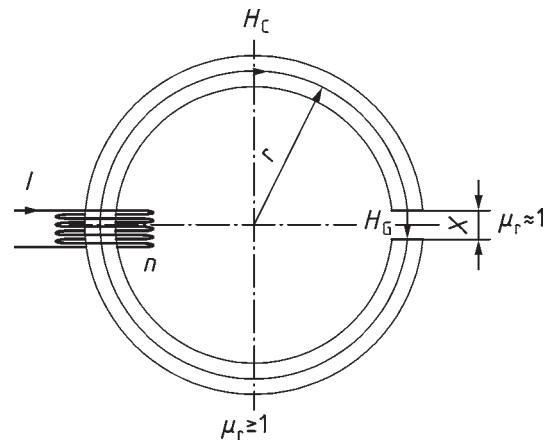

Key

I	electric current through the coil
n	number of windings in the coil
r	radius of the ferrous ring
x	length of the air gap
μ_r	relative magnetic permeability
H_C	magnetic field strength in the ferrous ring
H_G	magnetic field strength in the gap

Figure A.1 — Set-up with a ferrous ring having a gap

The magnetic flux density of a ferrous ring coil (see [Figure A.1](#)) with a small gap is calculated from the equation

$$B = \frac{n \cdot I \cdot \mu_0 \cdot \mu_r}{2 \cdot \pi \cdot r - x + \mu_r \cdot x} \quad (\text{A.1})$$

where

- B is the magnetic flux density;
- n is the number of windings;
- I is the electric current through the coil;
- μ_r is the relative magnetic permeability of the used ferrous material;

μ_0 is the magnetic constant;

r is the radius of the ferrous ring;

x is the length of the air gap.

If the gap length x is zero Formula (A.1) becomes

$$B = \frac{n \cdot I \cdot \mu_0 \cdot \mu_r}{2 \cdot \pi \cdot r} \quad (\text{A.2})$$

Formula (A.2) is identical to the formula describing a pure ferrous ring coil.

Considering the other extreme, if the gap length becomes identical to the coil length ($x = 2 \cdot \pi \cdot r$) Formula (A.1) becomes Formula (A.3), which describes an air ring coil:

$$B = \frac{n \cdot I \cdot \mu_0}{2 \cdot \pi \cdot r} \quad (\text{A.3})$$

A comparison of Formula (A.2) to Formula (A.3) shows that the magnetic flux density in the air gap decreases by the factor μ_r if the ferrous metal is completely replaced by air.

Annex B (informative)

Basic performance requirements for coating thickness gauges which are based on the magnetic method described in this International Standard

B.1 Technical specification

The manufacturer's technical specification should at least provide the following technical information for instruments and probes:

- a) principle of measurement;
- b) measuring range;
- c) basic information on measuring uncertainty or permissible error of measurement if measuring is carried out under conditions specified by the manufacturer;
- d) information on how measuring results are influenced by the material, curvature and thickness of the base metal and by the edge effect (measurements close to an edge);
- e) battery operating time;
- f) function of an under voltage monitor and automatic under voltage switch-off;
- g) permissible operating temperature;
- h) permissible storage temperature;
- i) available methods for calibration and adjustment;
- j) contact force of probes with spring loaded guiding sleeves;
- k) availability of temperature compensation;
- l) measuring rate;
- m) data memory (design, capacity, data communication);
- n) size and weight of instrument (with batteries) and probes.

B.2 Check/verification of instruments and probes

B.2.1 Prior to supply, after repair and at regular intervals after use

After the instruments and probes have been adjusted according to the manufacturer's instructions, the measuring accuracy should be checked and verified by using a plane and uncoated base metal and a representative number of coated calibration standards or calibration foils, whose coating or foil thicknesses should be equally distributed within the measuring range of the respective probe.

Measurement errors shall not exceed the manufacturer's technical specification.

B.2.2 Performed on site

The accuracy of instruments and probes should be verified daily. After the instrument has been adjusted according to the manufacturer's instructions, verification shall be made with an appropriate number of coated calibration standards made from the same base metal as the items to be measured or by means of calibration foils put onto the base metal to be measured. Their thicknesses should cover the expected coating thickness range. If curved coated items shall be measured, verification needs to be executed on items of the same base metal, geometry and curvature as the items to be measured.

Measurement errors shall not exceed the manufacturer's technical specification.

Annex C (informative)

Examples of experimental estimation of factors affecting the measurement

C.1 General

Factors affecting the measurement accuracy are summarized and described in [Clause 5](#). In practical measurements it is important to estimate the influence of these factors or the resulting uncertainty. Therefore, some examples of simple experiments are described in this annex in order to show how the influence of these factors can be estimated. These experiments also provide a basis for estimating the respective uncertainty.

The factors described in [C.2](#) to [C.5](#) can cause differently pronounced influences for an instrument working with combined measuring principles in one probe. Consequently, the factors should be estimated separately for each combined measuring principle.

C.2 Base metal thickness

A simple test to prove that the metal base thickness t_0 is larger than the critical minimum base metal thickness t_0^{crit} uses two (or more) clean, uncoated and even samples of the base metal with the thickness of interest and follows the procedure described in steps 1 to 4 below. The procedure is illustrated in [Figure C.1](#).

Step 1

Place the probe on the first sample. It should be proven that the reading is not affected by the edges of the sample (see [C.3](#)).

Step 2

Adjust the instrument to read zero.

Step 3

Place the second sample beneath the first one, place the probe on top of this stack and check the instrument reading. If the instrument reading is still zero with respect to the expected uncertainty, the base metal thickness t_0 is larger than the critical minimum base metal thickness t_0^{crit} and no additional uncertainty needs be considered. If the instrument reading changes negatively with respect to the expected uncertainty, t_0 is smaller than t_0^{crit} , i.e. the measurement is affected by the too small base metal thickness.

Step 4

If t_0 is smaller than t_0^{crit} , place a third sample beneath the stack of step 3, place the probe on top of this stack and check the instrument reading. If the instrument reading is still the same as in step 3 with respect to the uncertainty the critical minimum base metal thickness lies within $t_0 < t_0^{\text{crit}} < 2 t_0$. If the instrument reading shows a larger negative value than in step 3 then two times of t_0 is still smaller than t_0^{crit} . Continue to stack further samples in order to estimate t_0^{crit} .

The instrument may be used without correction provided that the base metal thickness t_0 is larger than t_0^{crit} . If t_0 is smaller than t_0^{crit} a special calibration correction is required and it shall be considered that possible base metal variations cause an increase of the respective thickness uncertainty.

The experimentally determined critical minimum base metal thickness t_0^{crit} can be used to estimate the resulting uncertainty.

In order to improve the accuracy of the estimation of t_0^{crit} samples with smaller thickness than t_0 should be used.

If the instrument does not display negative values, it is recommended to use a thin foil (e.g. 10 μm) between the probe and base metal in order to observe the decrease of the thickness.

NOTE The procedure to stack several samples in order to simulate an increase in the base metal thickness allows only a rough estimation of t_0^{crit} because the air gap between the samples causes a change of the magnetic properties of the sample stack in comparison with the respective homogeneous material. However, this simplified procedure can be carried out more easily than producing base metals with variable thickness.

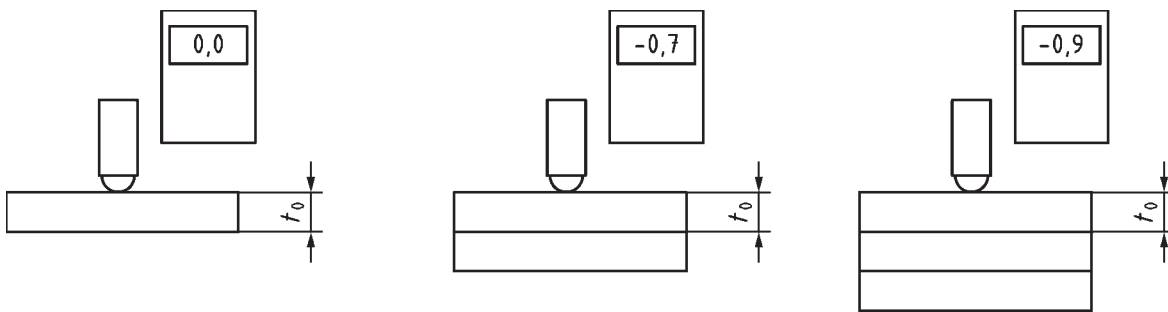

Figure C.1 — Schematic representation of the test for base metal thickness

C.3 Edge effect

A simple edge effect test, to assess the effect of the proximity of an edge, uses a clean, uncoated and even sample of the base metal and follows the procedure described in steps 1 to 4 below. The procedure is illustrated in [Figure C.2](#).

Step 1

Place the probe on the sample, sufficiently away from the edge.

Step 2

Adjust the instrument to read zero.

Step 3

Progressively bring the probe towards the edge and note where a change of the instrument reading occurs with respect to the expected uncertainty or to the given thickness tolerance.

Step 4

Measure the distance d from the probe to the edge (see [Figure C.2](#)).

The instrument may be used without correction provided that the probe is further from the edge than the distance as measured above. If the probe is used closer to the edge, a special adjustment or calibration correction is required or the additional resulting uncertainty for the used distance needs to be considered. If necessary, refer to the manufacturer's instructions.

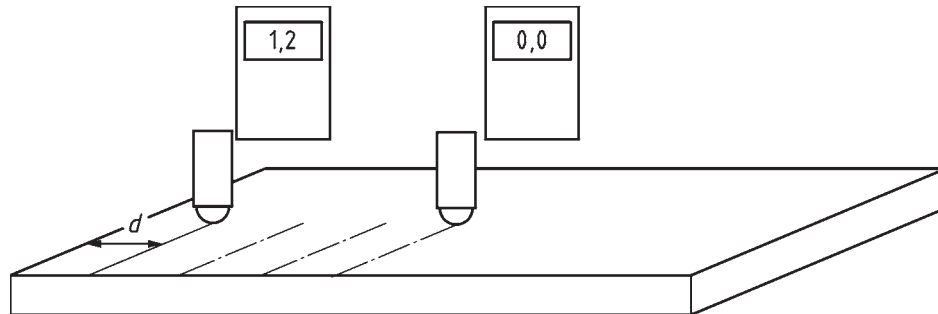

Key

d distance from the probe to the edge

Figure C.2 — Schematic representation of the test for edge effect

C.4 Surface curvature

A simple test to assess the effect of the influence of the sample surface curvature uses a clean uncoated sample of the base metal with different curvature diameters (e.g. cylinder) and follows the procedure described in steps 1 to 4 below. All used samples should provide the same material properties as the base metal. The procedure is illustrated in [Figure C.3](#) using the example of a convex curvature.

Step 1

Place the probe on an even sample (no curvature). It should be proven that the reading is not affected by the edges of the sample (see [C.3](#)) and that the base metal thickness of the sample is larger than the critical minimum base metal thickness (see [C.2](#)).

Step 2

Adjust the instrument to read zero.

Step 3

Place the probe on each sample starting with the largest available diameter and then continue the test with decreasing sample diameters. Note the diameter where a change of the instrument reading (positive increase) occurs with respect to the expected uncertainty or to the given thickness tolerance.

The instrument may be used without correction provided that the sample of interest shows a larger diameter than the noted one. If the diameter is smaller, an adjustment or special calibration correction is required or the additional resulting uncertainty for the used distance can be considered. If necessary, refer to the manufacturer's instructions.

In practical situations, the diameter of the samples of interest varies very often. In this situation, the smallest and the largest diameter expected should be estimated and the instrument should be adjusted on an uncoated sample close to the average diameter. As a result, the measured deviation for the smallest and largest diameter can be estimated from the described procedure and used to estimate the uncertainty. Take this uncertainty into account during the measurement.

In order to improve the accuracy of the estimation of the curvature influence, increase the number of samples with different diameters.

NOTE The same procedure can be used in cases where the samples show a concave curvature, however, this concave curvature results in negative thickness readings. If the instrument does not display negative values, it is recommended to use a thin foil (e.g. 10 µm) between the probe and base metal to observe the decrease of the thickness.

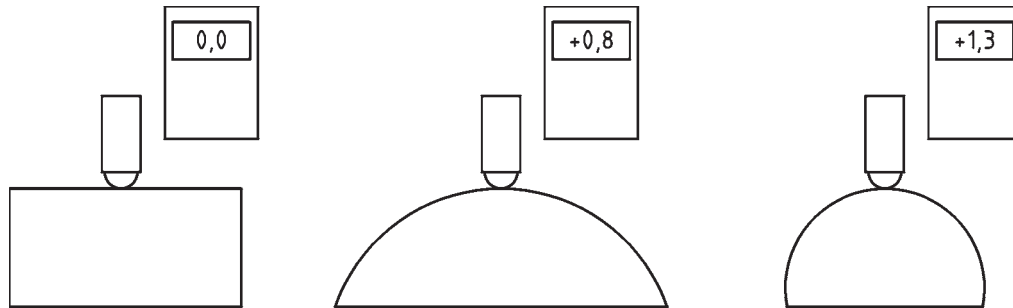

Figure C.3 — Schematic representation of the test for curvature effect

C.5 Magnetic properties of the base metal

In practical situations, the magnetic properties of the base metal varies very often. The simplified procedure described in steps 1 to 5 below helps to reduce this influence and estimate the resulting uncertainty. This procedure requires several uncoated, clean and even samples representing approximately the expected variation of the base metal variation. The procedure is illustrated in [Figure C.4](#).

Step 1

Place the probe on one of the samples. It should be proven that the reading is not affected by the edges of the sample (see [C.3](#)), that the base metal thickness of the sample is larger than the critical minimum base metal thickness (see [C.2](#)) and that the sample is even (with no curvature, see [C.4](#)).

Step 2

Adjust the instrument to read zero.

Step 3

Place the probe on each of the samples and notice the reading. It is recommended to carry out repeated measurements on each sample and to use the average value in the next steps.

Step 4

Calculate the average of the readings of all samples and select the sample with the smallest deviation from this average.

Step 5

Use this selected sample as a reference base metal to carry out the zero adjustment for all measurements.

The instrument may be used without correction provided that the deviation of the sample with the smallest reading (or with the largest reading) from the calculated average value is smaller than the expected uncertainty or the given thickness tolerance.

If there are larger variations, the selected sample should be used as a reference base metal and the estimated deviation of the readings of the described procedure can be used to estimate the uncertainty. Take this uncertainty into account during the measurements.

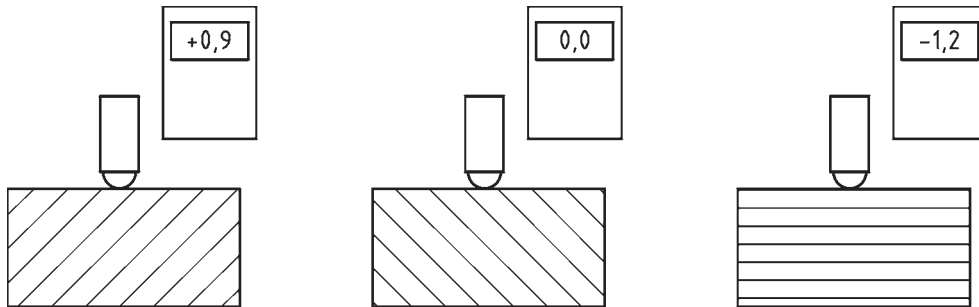

Figure C.4 — Schematic representation of the test for base metal permeability test

Annex D (informative)

Example of uncertainty estimation (see [Clause 8](#))

D.1 Sample details

The example sample to be measured is as follows:

- paint/steel (part of a car body);
- expected thickness is around 25 μm ;
- the base metal is not accessible, but possible thickness variations caused by the used car body steel production lots (permeability variations) have been determined by an experiment (see [C.5](#)): measurement of uncoated steel parts from car body production representing the variability of used steel from different suppliers, production lots, etc., resulting complete thickness variation range at $t = 25 \mu\text{m}$: $\Delta t_{\text{bm}} = \pm 1,2 \mu\text{m}$.

D.2 Steps

D.2.1 The example sample is measured by following these steps.

(1) Verify the probe calibration:

- ten repeated measurements with a reference foil of $t_r = 25,2 \mu\text{m}$ on base metal (including zeroing on base metal)
- the given tolerance of the reference foil is $T = \pm 0,5 \mu\text{m}$
- the used base metal is a selected reference base metal (see [C.5](#))
- the result is ($n = 10$) : $\bar{t} = 24,06 \mu\text{m}$ and $s(t) = 0,11 \mu\text{m}$
- calculate the uncertainty and E (see [8.2](#))

- the standard uncertainty of the reference foil is $u_r = \frac{T}{\sqrt{3}} = \frac{0,5 \mu\text{m}}{\sqrt{3}} = 0,29 \mu\text{m}$

- the standard uncertainty of the verification measurement (only the stochastic component is considered) is $u_{\text{sto}} = t \left(68,27 \% , n - 1 \right) \cdot \frac{s(t)}{\sqrt{n}} = 1,06 \cdot \frac{0,11 \mu\text{m}}{\sqrt{10}} = 0,04 \mu\text{m}$

- the combined uncertainty is $u_c = \sqrt{(0,04 \mu\text{m})^2 + (0,29 \mu\text{m})^2} = 0,29 \mu\text{m}$

- the expanded uncertainty is $U_{\text{cal}}(k = 2) = 2 \cdot u_c = 0,58 \mu\text{m}$

— the result is $E = \frac{|\bar{t} - t_r|}{U_{\text{cal}}(k=2)} = \frac{1,14 \mu\text{m}}{0,58 \mu\text{m}} = 1,96$

- calibration is not correct. A significant deviation has been detected, because $E = 1,96 > 1$, i.e. the difference between the measured value \bar{t} and the given reference foil value $|t - t_r|$ is larger than $U_{\text{cal}}(k=2) = 0,58 \mu\text{m}$; consequently the calibration accuracy can be improved by means of this reference foil.

(2) Adjust the instrument with the reference foil.

(3) Verify the improved probe calibration:

- ten repeated measurements (repeat of step 1)
- result ($n = 10$): $\bar{t} = 24,87 \mu\text{m}$ and $s(t) = 0,11 \mu\text{m}$
- calibration is ok, because $E = 0,56 < 1$, i.e. the difference $|\bar{t} - t_r|$ is smaller than $U_{\text{cal}}(k=2) = 0,58 \mu\text{m}$, no significant deviation can be proven now

(4) Measure the uncertainty of the probe calibration (result of step 3):

$$u_c = \sqrt{(0,03 \mu\text{m})^2 + (0,29 \mu\text{m})^2} = 0,29 \mu\text{m}$$

(5) Measure the sample:

- seven repeated measurements within the given measurement area of the sample
- result ($n = 7$): $\bar{t} = 22,8 \mu\text{m}$ and $s(t) = 0,76 \mu\text{m}$

(6) Calculate all measurement uncertainty components and the combined uncertainty:

- stochastic uncertainty (see 8.3): $u_{\text{sto}} = t(68,27\%, n-1) \cdot \frac{s(t)}{\sqrt{n}} = 1,09 \cdot \frac{0,76 \mu\text{m}}{\sqrt{7}} = 0,31 \mu\text{m}$
- standard uncertainty caused by possible base metal thickness deviation from calibration (expected thickness variation range (see 8.4): $\Delta t_{\text{bm}}(25 \mu\text{m}) = \pm 1,2 \mu\text{m}$: $u_{\text{bm}} = 0,69 \mu\text{m}$
- combined uncertainty (see 8.5):

$$u_c = \sqrt{u_{\text{cal}}^2 + u_{\text{sto}}^2 + u_{\text{bm}}^2} = \sqrt{(0,29 \mu\text{m})^2 + (0,31 \mu\text{m})^2 + (0,69 \mu\text{m})^2} = 0,81 \mu\text{m}$$

(7) Calculate the expanded uncertainty and expression of the result:

- expanded uncertainty (see 8.5): $U(k=2) = 2 \cdot u_c = 1,6 \mu\text{m}$
- final result of the measurement: $t = 23 \mu\text{m} \pm 1,6 \mu\text{m}$

D.2.2 All other possible factors affecting the measurement accuracy are considered to be negligible in this example (edge effect, base metal thickness, curvature, temperature drift, etc.).

D.2.3 Further conclusions: it is obvious that the resulting uncertainty is limited by the largest uncertainty component, in this case the possible base metal property variation (permeability variation). Therefore, an increase of the number of repeated measurements would reduce u_{sto} , however the combined uncertainty wouldn't be strongly affected in this way.

D.2.4 The final result of the thickness value should be rounded in accordance to the value of the estimated uncertainty.

Annex E (informative)

Basics of the determination of the uncertainty of a measurement of the used measurement method corresponding to ISO/IEC Guide 98-3

E.1 General

Coating thicknesses are generally determined as the mean value of several single measurements that are carried out at a fixed section of the layer's surface.

On the basis of these measurements, a mean value is allocated to the measurand "coating thickness". This is assigned an uncertainty value that provides information about the reliability of the allocated value.

Analysis is carried out progressively and begins by drawing up a model equation that shows the functional correlation between the indicated output value t and all the relevant influence quantities H_i , as shown in Formula (E.1):

$$t = F(H_0, H_1, H_2, \dots, H_i \dots H_n) \quad (\text{E.1})$$

To every influence quantity belongs a sensitivity coefficient c_i , which indicates how strong a modification ΔH_i effects the result t .

When the function F is given as analytic expression the sensitivity coefficients may be calculated by partial derivation, see Formula (E.2):

$$c_i = \frac{\delta t}{\delta H_i} \quad (\text{E.2})$$

If the kind of the functional correlation is unknown, an approximation by means of polynomial functions is recommended.

In many practical cases, this formulation is expressed by a linear dependence, i.e. the sensitivity coefficients become one. This situation arises, for example, in sections of limited coating thickness.

In order to summarize the uncertainties of various error influences appropriately, all single uncertainty components may be referred to a level of confidence of 68,27 %: the so-called "standard uncertainty".

Calculating the uncertainty of a measurement results in two types of uncertainties: Type A (see [E.2](#)) and Type B (see [E.3](#)).

E.2 Type A

The standard uncertainty of Type A is a measure of all random errors arising from unpredictable or stochastic temporal and spatial variations of influence quantities.

The standard uncertainty corresponds to the point of confidence of the mean value, see Formulae (E.3) and (E.4):

$$u_{\text{sto}} = t(68,27\%, n - 1) \cdot \frac{s(t)}{\sqrt{n}} \quad (\text{E.3})$$

where s is the empirical standard deviation of the repetition measurement n ,

$$s = \sqrt{\frac{\sum_{j=1}^n (\bar{x} - x_j)^2}{(n - 1)}} \quad (\text{E.4})$$

and $t(68,27\%, n - 1)$ student factor (degrees of freedom $f = n - 1$ and level of confidence with $p = 68,27\%$). Respective values are summarized in [Annex F](#).

E.3 Type B

Many influencing factors or errors are not described by Type A, e.g. the influencing factors of [Clause 5](#). These are classified as Type B.

In order to realize a balanced combination of those error influences with the errors of Type A, the ad hoc probability factors are allocated. In many practical cases, the influencing factors treated here are described by a uniform distribution (rectangle distribution).

If an influence quantity fluctuates within a section ΔH_i , the resulting uncertainty can be calculated as shown in Formula (E.5):

$$u_b) = \frac{|t_{\text{max}} - t_{\text{min}}|}{\sqrt{12}} \quad (\text{E.5})$$

The fluctuation sections are estimated or determined experimentally (see [Annex C](#)).

For the most part, uncertainty analysis uses uncertainties that are already known, e.g. when it comes to the statement of the uncertainty of reference standards. In this case, take into consideration that these statements of uncertainty are converted into the standard uncertainty, e.g. for $U(k = 2)$ follow the standard uncertainty shown in Formula (E.6):

$$u(68,27\%) = \frac{U(95,45\%)}{2} \quad (\text{E.6})$$

In order to summarize all investigated uncertainties, the so-called “combined uncertainty” is calculated. This is done by multiplying the fractions of the standard uncertainty by their sensitivity coefficients and adding them up squared. In a simplified case the sensitivity coefficients are equally one, see Formula (E.7):

$$u = \sqrt{\sum_i (c_i u_i)^2} \quad (\text{E.7})$$

Multiplying with an indicated coverage factor of $k \geq 2$ results in an expanded uncertainty to be calculated, which should be indicated in the actual result, see Formula (E.8):

$$U = k \cdot u \quad (\text{E.8})$$

Annex F (informative)

Table of the student factor

Table F.1 — The student factor

Number of measurements <i>n</i>	Fraction <i>p</i> in percent	
	68,27 %	95,45 %
2	1,84	13,97
3	1,32	4,53
4	1,20	3,31
5	1,14	2,87
6	1,11	2,65
7	1,09	2,52
8	1,08	2,43
9	1,07	2,37
10	1,06	2,32
11	1,05	2,28
12	1,05	2,25
13	1,04	2,23
14	1,04	2,21
15	1,04	2,20
16	1,03	2,18
17	1,03	2,17
18	1,03	2,16
19	1,03	2,15
20	1,03	2,14
∞	1,00	2,00

Annex G (informative)

Details on precision

G.1 General notes on the round-robin test

A round-robin test was carried out to determine the precision data of using magnetic-induction gauges for measuring the coating thickness.

Twelve laboratories participated in the round-robin test.

G.2 Samples

For the round-robin test, eight different coatings on different steel-substrates were prepared (see [Table G.1](#)).

To define the measurement, five measurement points were assigned on each sample.

Table G.1 — Samples

Sample number	Substrate	Coating	Coating thickness approx. μm	Calibration foil μm
P01	Steel	Red car repair finish coating	80	125
P03	Steel, double	Green electro deposition coating (ED)	20	25
P04	Steel	Green electro deposition coating	20	25
P05	Steel, double	ED coat + base coat + clear coat	120	125
P06	Steel	ED coat + base coat + clear coat	120	125
P09	Coil panel	Zinc + primer coat	10	12
P10	Coil panel	Zinc + primer coat + base coat	25	25
P14	Steel	Chrome	8	12

G.3 Film thickness gauges

For the round-robin test, thickness gauges with different types of probes from three different manufacturers were used.

G.4 Calibration

A two point calibration respectively adjustment of the gauges was done (zero point and thickness of calibration foil).

Two different calibration methods with certified plastic foils are executed. The following measurements based on these calibrations:

- Reference method – R: calibration and adjustment with the foil on uncoated original samples respectively back side of the sample;
- Standard method – S: calibration and adjustment with the foil on a coated steel standard panel.

The thicknesses of the calibration foils were: 12 µm, 25 µm and 125 µm.

Coating thickness measurements were done directly after every calibration and adjustment.

G.5 Number of measurements

For the calculation of the repeatability limit the measurements on the first marked point were carried out in triplicate.

Afterwards the other four marked points were measured.

G.6 Evaluation

G.6.1 General

The statistical evaluation was carried out following ISO 5725-2 and ISO/TR 22971.

Evaluation was carried out for each calibration method with particular calibration foil.

G.6.2 Evaluation of first measuring point

The repeatability limit, r_{x_1} , and the reproducibility limit, R_{x_1} , are calculated from the triplicate values from the first measuring point.

G.6.3 Evaluation of all five measuring points

The repeatability limit, $r_{\bar{x}}$, and reproducibility limit, $R_{\bar{x}}$, are calculated from all five measuring points. For the first measuring point the arithmetic mean from the triplicate measurements is used.

[Table G.2](#) contains the results for repeatability limits and reproducibility limits calculated from the first measuring point in comparison to the respective limits calculated from all five measuring points.

Table G.2 — Repeatability limit, r , and reproducibility limit, R

Calibration methods	r_{x_1} µm	R_{x_1} µm	$r_{\bar{x}}$ µm	$R_{\bar{x}}$ µm
12-R	1,3	3,2	1,4	3,4
12-S	1,5	4,2	2,0	4,3
25-R	1,2	5,4	1,7	5,5
25-S	1,3	6,0	1,6	6,0
125-R	2,0	4,3	6,8	7,4
125-S	1,4	5,8	7,0	8,7
r_{x_1} and R_{x_1} Repeatability limit and reproducibility limit of first measuring point (triple measurement). $r_{\bar{x}}$ and $R_{\bar{x}}$ Repeatability limit and reproducibility limit of all five measuring points.				

NOTE The greater result of the repeatability limit, r_{x_1} , at 125-R compared to 125-S could have several reasons.

[Figure G.1](#) to [G.3](#) show the results of thickness measurements based on the three different thickness calibration foils.

In which

R - Reference method and

S - Standard method (see also G.4).

In Figure G.1 and G.2 the samples P09 and P10 have a greater difference between the reference and standard method calibration. The calibration for the reference method was done on the back side of the samples which was zinc coated. The thickness of the zinc coat was, when setting the gauge on zero included. The thickness difference based on the standard calibration method - S is the thickness of the zinc coat.

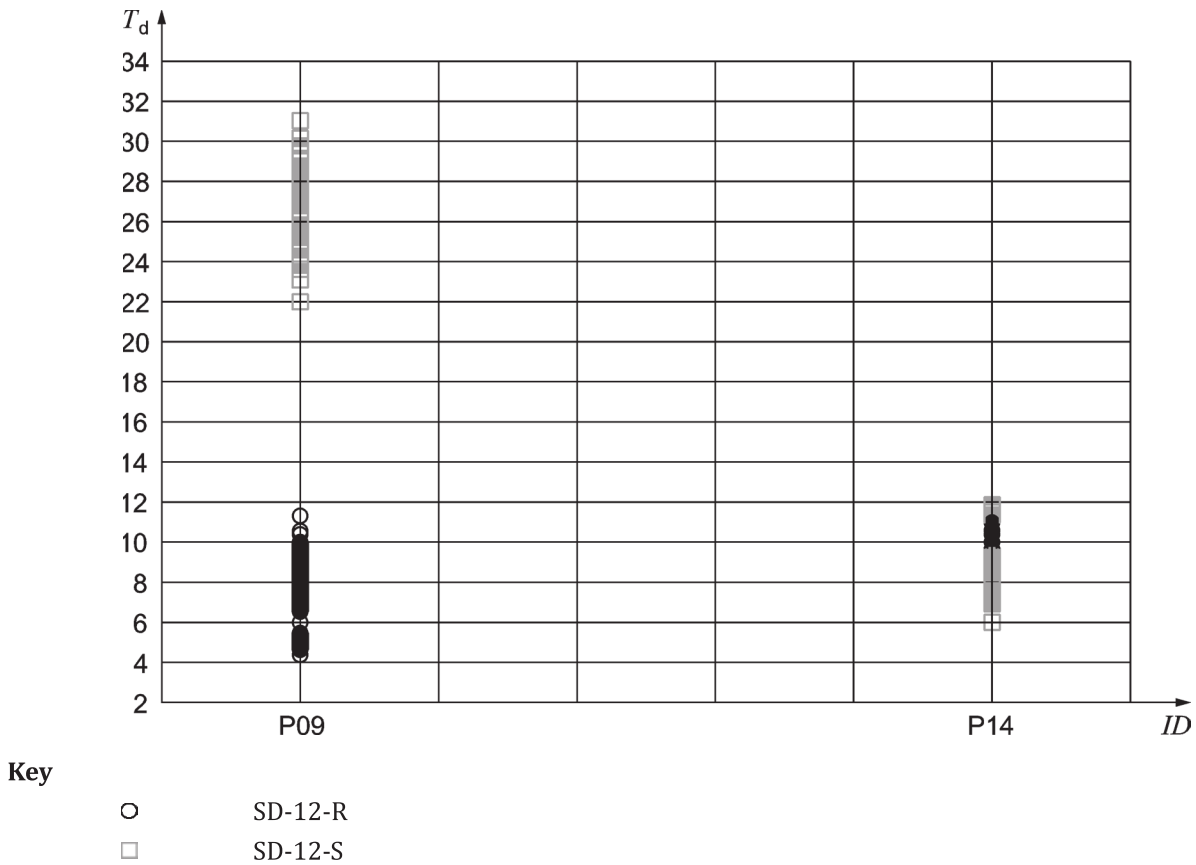

Figure G.1 — Comparison of reference and standard method calibration with 12 μm foil

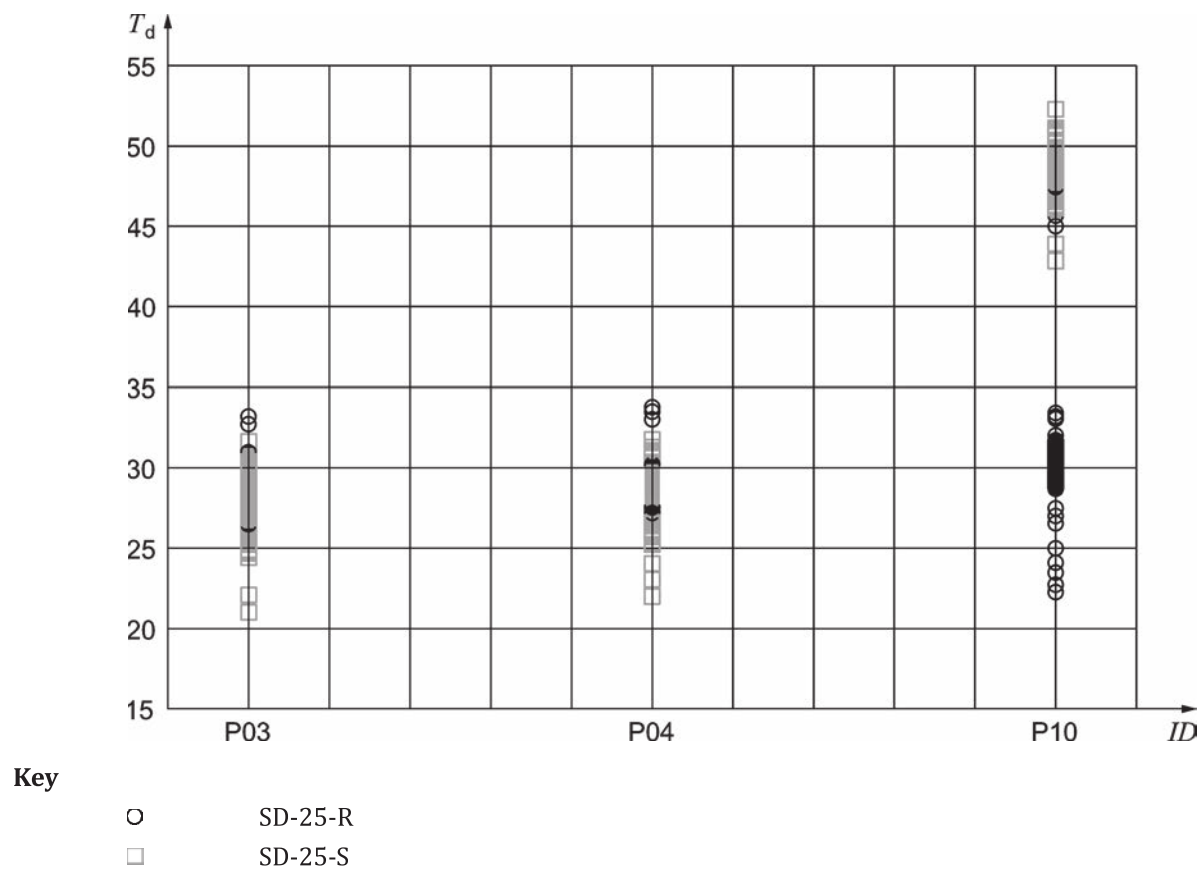
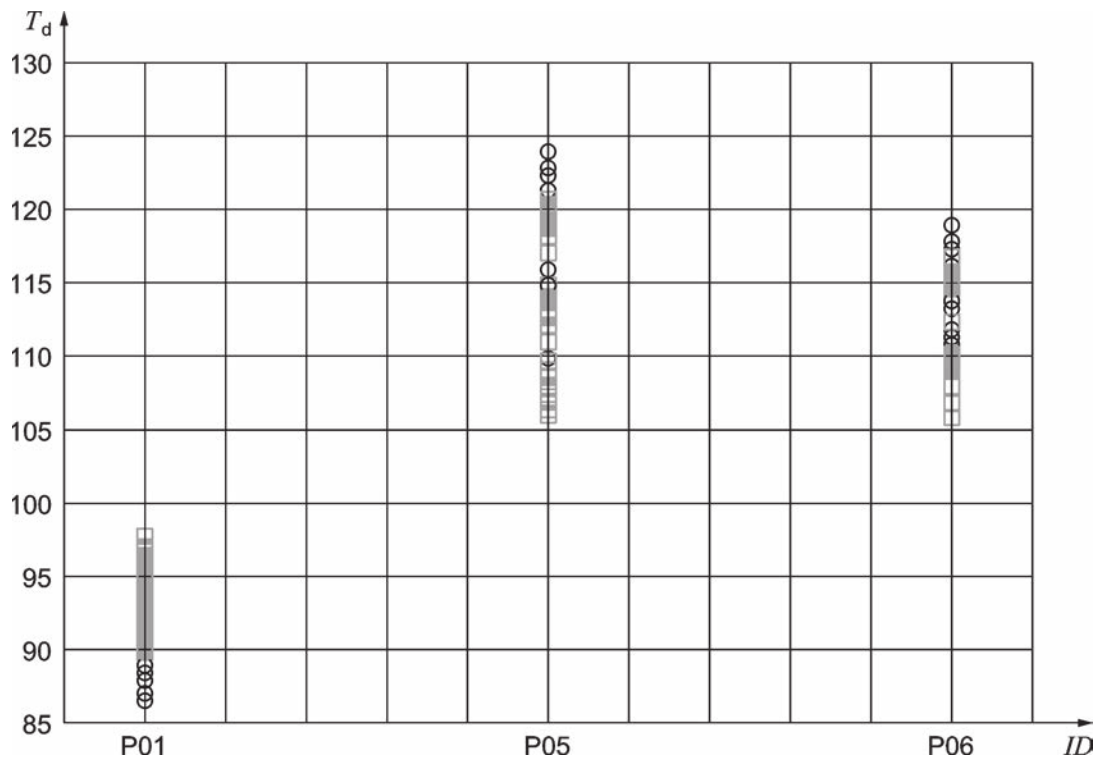

Figure G.2 — Comparison of reference and standard method calibration with 25 μm foil



Key

- SD-125-R
- SD-125-S

Figure G.3 — Comparison of reference and standard method calibration with 125 μm foil

Bibliography

- [1] ISO 2360, *Non-conductive coatings on non-magnetic electrically conductive basis materials — Measurement of coating thickness — Amplitude-sensitive eddy-current method*
- [2] ISO 2361, *Electrodeposited nickel coatings on magnetic and non-magnetic substrates — Measurement of coating thickness — Magnetic method*
- [3] ISO 2808, *Paints and varnishes — Determination of film thickness*
- [4] ISO 5725-2, *Accuracy (trueness and precision) of measurement methods and results — Part 2: Basic method for the determination of repeatability and reproducibility of a standard measurement method*
- [5] ISO 19840, *Paints and varnishes — Corrosion protection of steel structures by protective paint systems — Measurement of, and acceptance criteria for, the thickness of dry films on rough surfaces*
- [6] ISO 21968, *Non-magnetic metallic coatings on metallic and non-metallic basis materials — Measurement of coating thickness — Phase-sensitive eddy-current method*
- [7] ISO/TR 22971, *Accuracy (trueness and precision) of measurement methods and results — Practical guidance for the use of ISO 5725-2:1994 in designing, implementing and statistically analysing interlaboratory repeatability and reproducibility results*
- [8] ISO/IEC Guide 99:2007, *International vocabulary of metrology — Basic and general concepts and associated terms (VIM)*

