

INTERNATIONAL
STANDARD

ISO
2176

Second edition
1995-03-15

**Petroleum products — Lubricating
grease — Determination of dropping point**

*Produits pétroliers — Graisses lubrifiantes — Détermination du point de
goutte*



Reference number
ISO 2176:1995(E)

Foreword

ISO (the International Organization for Standardization) is a worldwide federation of national standards bodies (ISO member bodies). The work of preparing International Standards is normally carried out through ISO technical committees. Each member body interested in a subject for which a technical committee has been established has the right to be represented on that committee. International organizations, governmental and non-governmental, in liaison with ISO, also take part in the work. ISO collaborates closely with the International Electrotechnical Commission (IEC) on all matters of electrotechnical standardization.

Draft International Standards adopted by the technical committees are circulated to the member bodies for voting. Publication as an International Standard requires approval by at least 75 % of the member bodies casting a vote.

International Standard ISO 2176 was prepared by Technical Committee ISO/TC 28, *Petroleum products and lubricants*.

This second edition cancels and replaces the first edition (ISO 2176:1972), which has been technically revised.

Annex A forms an integral part of this International Standard.

© ISO 1995

All rights reserved. Unless otherwise specified, no part of this publication may be reproduced or utilized in any form or by any means, electronic or mechanical, including photocopying and microfilm, without permission in writing from the publisher.

International Organization for Standardization
Case Postale 56 • CH-1211 Genève 20 • Switzerland

Printed in Switzerland

Introduction

In general, the dropping point of a lubricating grease is the temperature at which the grease passes from a semisolid to a liquid state under the conditions of test. This change in state is typical of greases containing soaps of conventional types as thickeners. Greases containing materials other than conventional soaps as thickeners may, without change in state, exhibit oil separation.

Cooperative testing indicates that results determined by this International Standard are generally in agreement with those obtained by the method, to be given in a future International Standard on lubricating greases, for the determination of dropping point (wide temperature range). In cases where results differ, there is no known significance. However, agreement between producer, consumer and supplier as to the test method to be used is advisable.

This page intentionally left blank

Petroleum products — Lubricating grease — Determination of dropping point

WARNING — The use of this International Standard may involve hazardous materials, operations and equipment. This standard does not purport to address all of the safety problems associated with its use. It is the responsibility of the user of this standard to establish appropriate safety and health practices and determine the applicability of regulatory limitations prior to use.

1 Scope

This International Standard specifies a method for the determination of the dropping point of lubricating grease.

NOTE 1 Results of the dropping point test may be used as an indication of the maximum temperature to which a grease can be exposed without complete liquefaction or excessive oil separation, for indication of the grease as to type, and for establishment of manufacturing or quality control limits for this characteristic. Results should not be considered as having any direct bearing on service performance unless such correlation has been established.

2 Definition

For the purposes of this International Standard, the following definition applies.

2.1 dropping point: Temperature at which a drop of lubricating grease is extruded from the bottom of a specialized cup under the conditions of this test.

NOTE 2 For certain greases, the temperature recorded is that when the first portion of extruded material touches the bottom of the test tube holding the cup.

3 Apparatus

3.1 Grease cup, of chromium-plated brass, conforming to the dimensions given in figure 1.

3.2 Test tube, of heat-resistant borosilicate glass, with rim, conforming to the dimensions shown in figure 2. The tube shall have three indentations on the circumference to support the grease cup at about the point shown in figure 2.

3.3 Thermometers, partial immersion type, conforming to the specification given in annex A.

3.4 Oil bath, consisting of a 400 ml beaker filled with a suitable oil to such a level to permit the test tube (3.2) to be suspended to the correct depth (see 4.5), but allowing for expansion of the fluid at the upper limit of the fluid's operation.

3.5 Ring stand and ring, for support of the oil bath.

3.6 Cup plug gauge, as illustrated in figure 3.

3.7 Thermometer depth gauge, as illustrated in figure 4.

Dimensions in millimetres

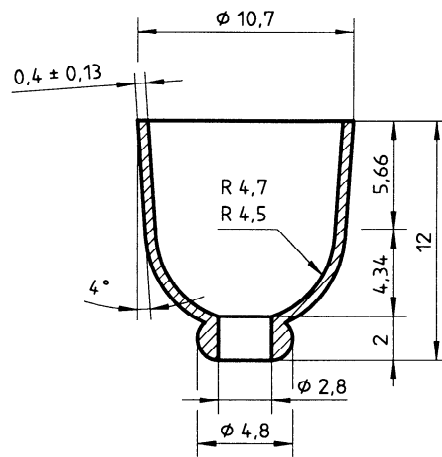

Figure 1 — Grease cup

Dimensions in millimetres

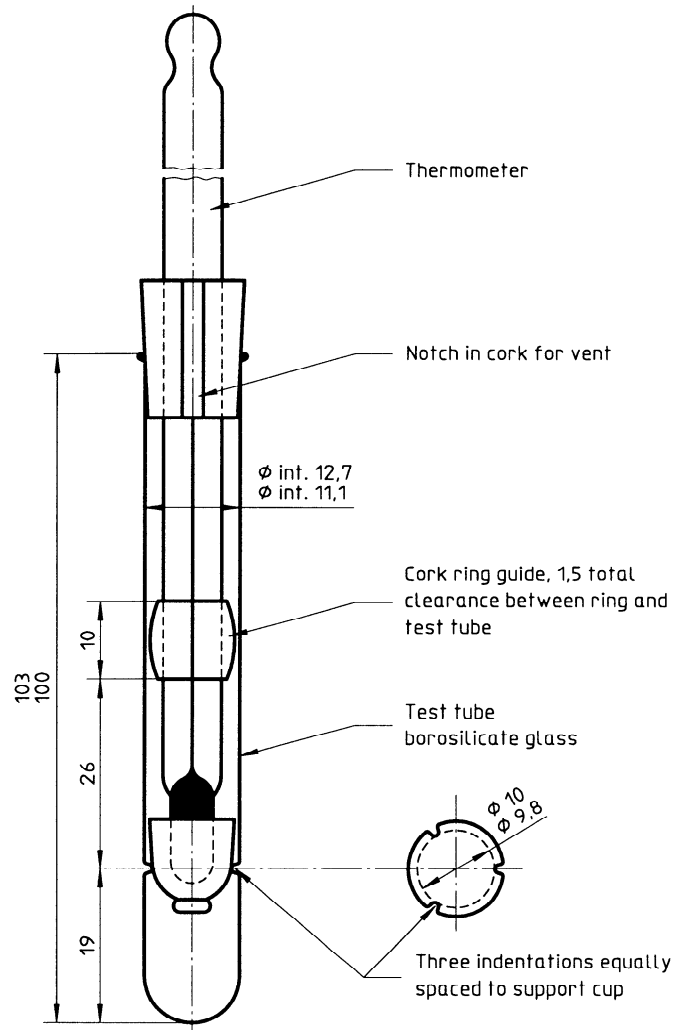

Figure 2 — Assembled apparatus

Dimensions in millimetres

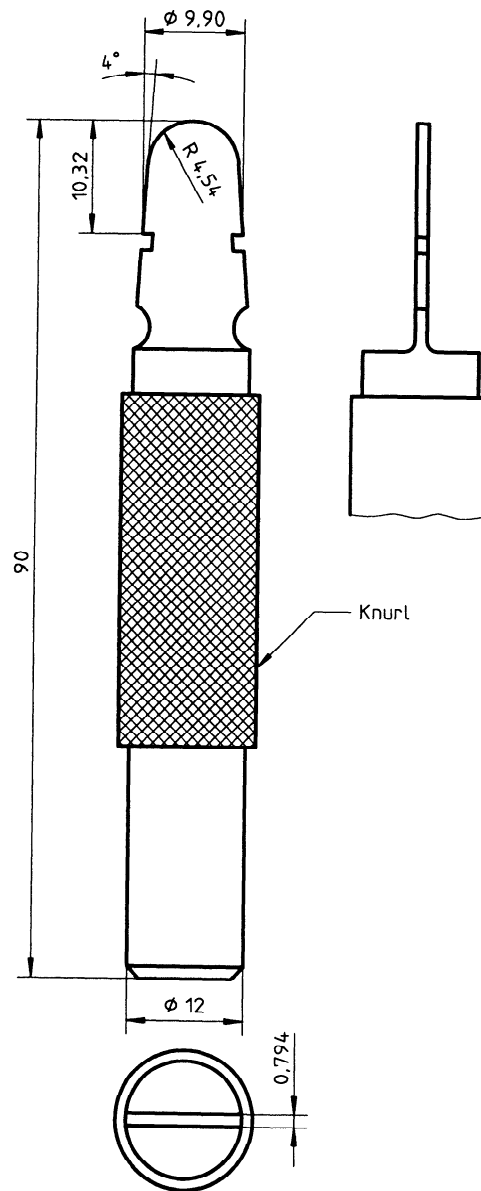

Figure 3 — Cup plug gauge

Dimensions in millimetres

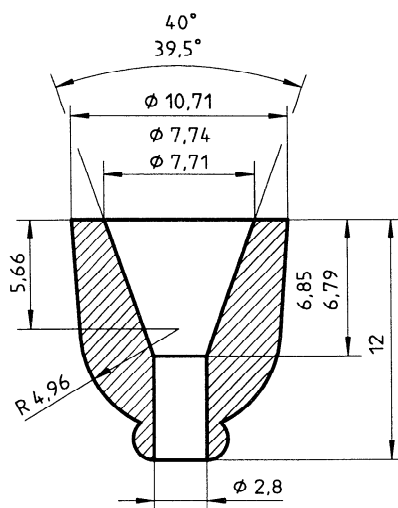

Figure 4 — Thermometer depth gauge

3.8 Clamps for thermometers.

3.9 Corks, as illustrated in figure 2.

3.10 Polished metal rod, 1,2 mm to 1,6 mm in diameter and 150 mm in length.

3.11 Heater, preferably immersed electrical-resistance type, regulated by voltage control.

3.12 Stirrer.

4 Procedure

4.1 Use the cup plug gauge (figure 3) to select a grease cup (3.1) conforming to the dimensions of the rounded end of the gauge. Check the diameter of the bottom opening of the cup, using as gauges a 2,78 mm diameter rod and 2,82 mm diameter rod. The orifice shall allow the 2,78 mm rod to pass easily, but not the 2,82 mm rod. If the orifice is undersized it shall be reamed to the correct size or the cup shall be discarded. If the orifice is too large, the cup shall be discarded.

4.2 Fill the grease cup with a sample of the grease to be tested by pressing the larger cup opening into the grease container until the cup is filled. Remove excess grease with a spatula. Gently press the cup, held in a vertical position with the smaller opening at the bottom, down over the metal rod (3.10) until the latter protrudes approximately 25 mm. Press the rod against the cup in such a manner that the rod makes

contact at both the upper and the lower peripheries of the cup. Maintain this contact, rotating the cup on the rod along the index finger to give a spiral-like motion down the rod to remove a conical section of the grease which adheres to the rod. As the cup approaches the end of the rod, carefully slip the rod out of the cup so that a smooth film of grease, free of air bubbles and of reproducible thickness, remains inside the cup.

4.3 Place the corks (3.9) as shown in figure 2. With the thermometer depth gauge (3.7), figure 4, in position in the test tube (3.2), adjust the position of the upper cork so that the thermometer bulb makes positive contact with the bottom of the depth gauge. Observe the position of the top edge of the upper cork relative to the thermometer stem as well as the position of the top edge of the test tube relative to the cork. Ensure that the thermometer is inserted to the same depth when the apparatus is reassembled with the grease cup in position.

4.4 Replace the thermometer depth gauge with the grease cup containing the grease so that the thermometer is inserted to the previously gauged depth. When properly inserted, the bulb of the thermometer shall not touch either the grease sample or the cup.

4.5 Suspend the test tube in the oil bath (3.4) to a depth corresponding to the 76 mm immersion mark on the thermometer.

NOTE 3 This should leave the test tube rim at least 6 mm above the oil level.

4.6 Suspend the second thermometer in the oil bath so that its bulb is at approximately the same level as the bulb of the test tube thermometer.

4.7 Stir the oil bath and heat at a rate of 4 °C/min to 7 °C/min until the bath reaches a temperature approximately 17 °C below that of the expected dropping point of the grease. At this point reduce the rate of heating so that the temperature difference between the test tube and the oil bath decreases to 2 °C, then continue heating the oil bath at a rate of temperature rise between 1,0 °C/min and 1,5 °C/min until material gradually protrudes through the orifice of the grease cup. When a drop of material falls, note the temperatures on the two thermometers and record their average, to the nearest 1 °C, as the dropping point of the grease.

NOTES

4 Certain greases, upon melting, form a drop with a tailing thread which may break off or which may hold until the drop reaches the bottom of the test tube; in any case, the observed dropping point should be taken as the temperature, observed when the drop reaches the bottom of the test tube.

5 The dropping points of some greases, particularly those containing simple aluminium soaps, are known to decrease upon ageing, the change being much greater than the deviation permitted in results obtained by different laboratories. Therefore, comparative tests between laboratories should be made within a period of 6 days.

6 Two determinations may be made simultaneously in the same bath provided both samples have approximately the same dropping points.

5 Expression of results

The results shall be expressed as the average of the two temperature readings, one on the thermometer in the oil bath and the other on the thermometer in the test tube, taken to the nearest 1 °C.

6 Precision

The precision of the method, as obtained by statistical examination of interlaboratory test results, is as follows:

6.1 Repeatability

The difference between two successive test results, obtained by the same operator with the same apparatus under constant operating conditions on identical test material would in the long run, in the normal and correct operation of the test method, exceed 7 °C only in one case in 20.

6.2 Reproducibility

The difference between two single and independent test results, obtained by different operators working in different laboratories on identical test material would in the long run, in the normal and correct operation of the test method, exceed 13 °C only in one case in 20.

7 Test report

The test report shall contain at least the following information:

- a) a reference to this International Standard or to a corresponding national standard;
- b) sufficient details for complete identification of the product tested;
- c) the result of the test (see clause 5);
- d) any deviation, by agreement or otherwise, from the procedure specified;
- e) the date of the test.

Annex A

(normative)

Thermometer specifications

Range	– 5 °C to + 300 °C
Immersion depth	76 mm
Graduation	1 °C (blank sign)
Longer lines at each	5 °C
Figured at each	10 °C
Scale error not exceeding	1 °C
Overall length	390 mm ± 5 mm
Stem diameter	6,5 mm ± 0,5 mm
Bulb length	10 mm to 15 mm
Bulb diameter	5,5 mm ± 0,5 mm
Distance from bottom of bulb to 0 °C line	100 mm to 110 mm
Distance from bottom of bulb to 300 °C line	329 mm to 358 mm

NOTE 7 Thermometer ASTM 2C/IP 62 C conforms to the above specification.

This page intentionally left blank

ICS 75.100

Descriptors: petroleum products, lubricants, greases, tests, drop-point determination.

Price based on 6 pages
