

INTERNATIONAL  
STANDARD

**ISO**  
**2162-1**

First edition  
1993-12-01

---

---

**Technical product documentation —  
Springs —**

**Part 1:  
Simplified representation**

*Documentation technique de produits — Ressorts —  
Partie 1: Représentation simplifiée*



Reference number  
ISO 2162-1:1993(E)

## Foreword

ISO (the International Organization for Standardization) is a worldwide federation of national standards bodies (ISO member bodies). The work of preparing International Standards is normally carried out through ISO technical committees. Each member body interested in a subject for which a technical committee has been established has the right to be represented on that committee. International organizations, governmental and non-governmental in liaison with ISO, also take part in the work. ISO collaborates closely with the International Electrotechnical Commission (IEC) on all matters of electrotechnical standardization.

Draft International Standards adopted by the technical committees are circulated to the member bodies for voting. Publication as an International Standard requires approval by at least 75 % of the member bodies casting a vote.

International Standard ISO 2162-1 was prepared by Technical Committee ISO/TC 10, *Technical drawings, product definition and related documentation*, Sub-Committee SC 6, *Mechanical engineering documentation*.

This first edition of ISO 2162-1 cancels and replaces ISO 2162:1973, of which it constitutes an extension and technical revision.

ISO 2162 consists of the following parts, under the general title *Technical product documentation — Springs*:

- *Part 1: Simplified representation*
- *Part 2: Presentation of data for cylindrical helical compression springs*
- *Part 3: Vocabulary*

© ISO 1993

All rights reserved. No part of this publication may be reproduced or utilized in any form or by any means, electronic or mechanical, including photocopying and microfilm, without permission in writing from the publisher.

International Organization for Standardization  
Case Postale 56 • CH-1211 Genève 20 • Switzerland

Printed in Switzerland

# Technical product documentation — Springs —

## Part 1: Simplified representation

### 1 Scope

This part of ISO 2162 gives rules for the simplified representation of compression, extension, torsion, disc, spiral and leaf springs on technical drawings.

### 2 Normative references

The following standards contain provisions which, through reference in this text, constitute provisions of this part of ISO 2162. At the time of publication, the editions indicated were valid. All standards are subject to revision, and parties to agreements based on this part of ISO 2162 are encouraged to investigate the possibility of applying the most recent editions of the standards indicated below. Members of IEC and ISO maintain registers of currently valid International Standards.

ISO 2162-2:1993, *Technical product documentation — Springs — Part 2: Presentation of data for cylindrical helical compression springs*.

ISO 5261:1981, *Technical drawings for structural metal work*.

### 3 General

In simplified representations, springs are represented as follows.

- Coiled wire springs: by a line following the axis of the spring wire.

- Other types of springs: by lines showing the characteristics of the respective type of springs and their elements.



The representations shown are examples only.

### 4 Helical compression springs

The following requirements shall be applied for the indication of the geometrical characteristics of wire-made springs on a simplified representation.

#### a) Cross-section of the material

Cylindrical: the appropriate graphical symbol in accordance with ISO 5261 ( $\emptyset$ ) need not be indicated.

Other than cylindrical: the appropriate graphical symbol in accordance with ISO 5261 shall be indicated (e.g. , ).

#### b) Direction of helix

Right-hand: assumed as normal and the designation RH need not be indicated.

Left-hand: exceptional and the designation LH<sup>1)</sup> shall be indicated.

#### c) Shape of ends

Ground: no indication is necessary.

Other than ground: the type shall be specified on the drawing, with dimensions if necessary (see ISO 2162-2).

1) In accordance with the rules given for the indication of left-hand screw threads (see ISO 5864:1978, *ISO inch screw threads — Allowances and tolerances*, clause 11).

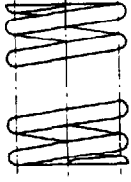
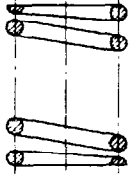
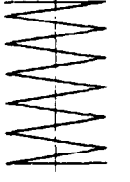
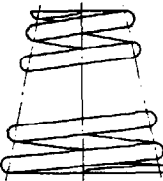
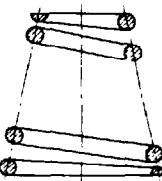
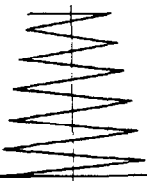
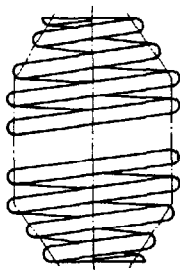
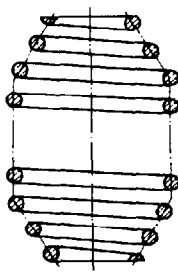
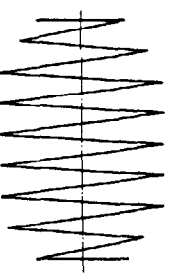
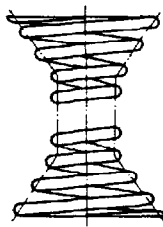
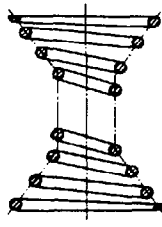
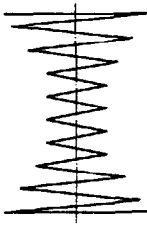
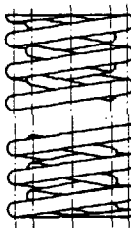
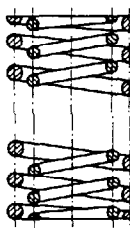
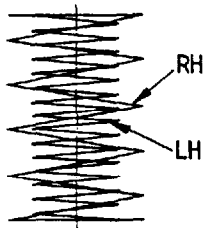
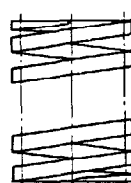
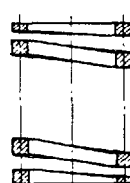
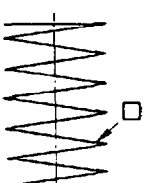
No.	Type of spring	Representation		
		View	Section	Simplified
4.1	Cylindrical helical compression spring			
4.2	Conical helical compression spring			
Combinations of cylindrical (4.1) and conical (4.2) helical compression springs.				
4.3	Double-conical helical compression spring Barrel spring			
4.4	Double-conical helical compression spring Waisted spring			
4.5	Spring nest of, for example, two cylindrical helical compression springs			
4.6	Cylindrical helical compression spring of material having square cross-section			

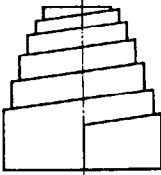
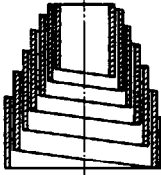
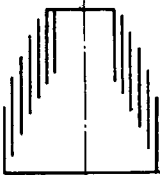
No.	Type of spring	Representation		
		View	Section	Simplified
4.7	Conical helical compression spring of strip having rectangular cross-section  Volute spring			

## 5 Helical extension springs

The requirements for the indication of the cross-section of the material and direction of helix are identical to those given in clause 4.

The shape of the ends shall be specified on the drawing, with dimensions if necessary.

The spring and its ends usually have the same diameter.

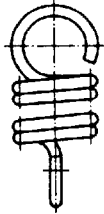
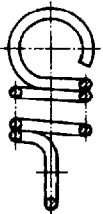
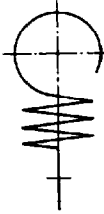
No.	Type of spring	Representation		
		View	Section	Simplified
5.1	Cylindrical helical extension spring			

## 6 Torsion springs

The requirements for the indication of the direction of helix and the cross-section of the material for 6.1 are identical to those given in clause 4. For 6.2 and 6.3, the cross-section of the material shall be indicated.

The shape of the ends shall be specified on the drawing, with dimensions if necessary.

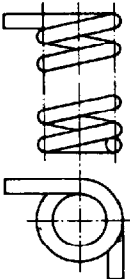
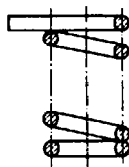
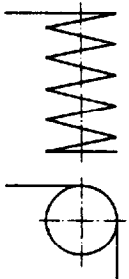
No.	Type of spring	Representation		
		View	Section	Simplified
6.1	Cylindrical helical torsion spring			

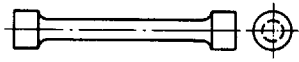
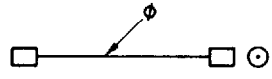
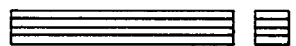
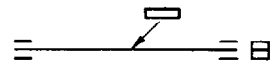
No.	Type of spring	Representation	
		View	Simplified
6.2	Torsion bar spring having circular cross-section		
6.3	Stacked laminated torsion bar spring of strips having rectangular cross-section		

### 7 Disc springs (Belleville)

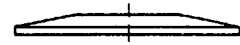
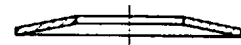
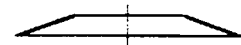
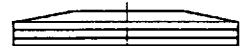
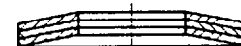
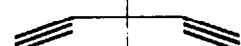
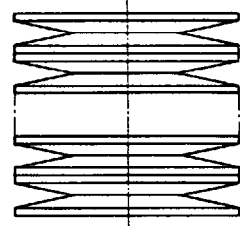
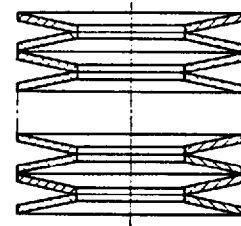
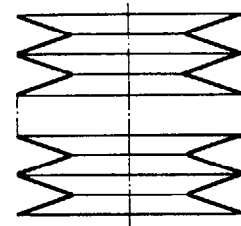
No.	Type of spring	Representation		
		View	Section	Simplified
7.1	Disc spring, single			
7.2	Multi-disc spring (disc laminated in parallel)			
7.3	Multi-disc spring (disc laminated in series) Disc spring column			





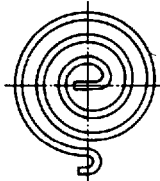
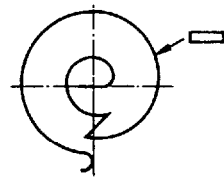

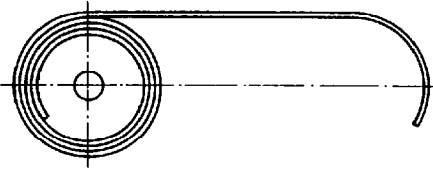
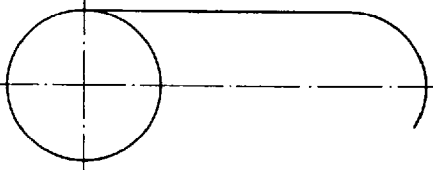
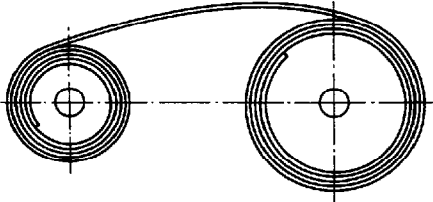
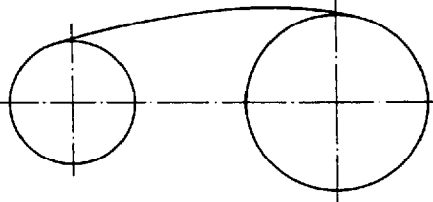
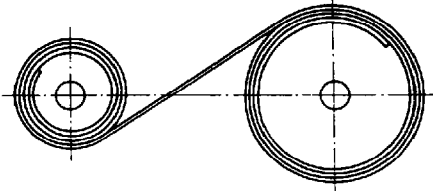
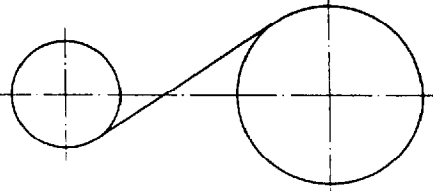
### 8 Spiral springs



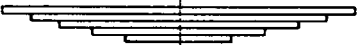

The cross-section of the material shall be indicated (see example in 8.1). In cases 8.1 and 8.2 the shape of the ends needs to be indicated.

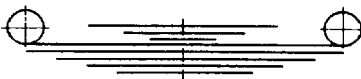
No.	Type of spring	Representation	
		View	Simplified
8.1	Spiral spring of strip having rectangular cross-section		

No.	Type of spring	Representation	
		View	Simplified
8.2	Constant force extension spring		
8.3	Constant force spring — A-Motor		
8.4	Constant force spring — B-Motor		

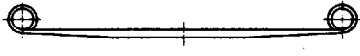
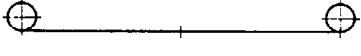
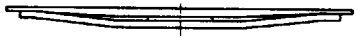
### 9 Leaf springs

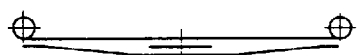
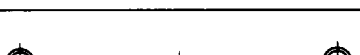
No.	Type of spring	Representation	
		View	Simplified
9.1	Laminated leaf spring without eyes		
9.2	Laminated leaf spring with eyes		
9.3	Laminated leaf spring with eyes and helper spring		
9.4	Laminated leaf spring with eyes and auxiliary spring		

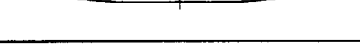
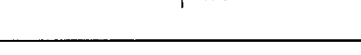
No.	Type of spring	Representation	
		View	Simplified
9.5	Parabolic single-leaf spring with eyes		
9.6	Parabolic multi-leaf spring without eyes		
9.7	Parabolic multi-leaf spring with eyes		
9.8	Parabolic multi-leaf spring with eyes and helper spring		
9.9	Parabolic multi-leaf spring with eyes and auxiliary spring		



**ISO 2162-1:1993(E)**

---

---

**UDC 744.42:62-272**

**Descriptors:** *drawings, technical drawings, graphic methods, springs.*

**Price based on 6 pages**

---

---