

INTERNATIONAL  
STANDARD

ISO  
2160

Third edition  
1998-09-15

---

---

**Petroleum products — Corrosiveness to  
copper — Copper strip test**

*Produits pétroliers — Action corrosive sur le cuivre — Essai à la lame de  
cuivre*



Reference number  
ISO 2160:1998(E)

## **Foreword**

ISO (the International Organization for Standardization) is a worldwide federation of national standards bodies (ISO member bodies). The work of preparing International Standards is normally carried out through ISO technical committees. Each member body interested in a subject for which a technical committee has been established has the right to be represented on that committee. International organizations, governmental and non-governmental, in liaison with ISO, also take part in the work. ISO collaborates closely with the International Electrotechnical Commission (IEC) on all matters of electrotechnical standardization.

Draft International Standards adopted by the technical committees are circulated to the member bodies for voting. Publication as an International Standard requires approval by at least 75 % of the member bodies casting a vote.

International Standard ISO 2160 was prepared by Technical Committee ISO/TC 28, *Petroleum products and lubricants*.

This third edition cancels and replaces the second edition (ISO 2160:1985), of which it constitutes a technical revision.

Annexes A and B of this International Standard are for information only.

© ISO 1998

All rights reserved. Unless otherwise specified, no part of this publication may be reproduced or utilized in any form or by any means, electronic or mechanical, including photocopying and microfilm, without permission in writing from the publisher.

International Organization for Standardization  
Case postale 56 • CH-1211 Genève 20 • Switzerland  
Internet [iso@iso.ch](mailto:iso@iso.ch)

Printed in Switzerland

# Petroleum products — Corrosiveness to copper — Copper strip test

**WARNING** — The use of this International Standard may involve hazardous materials, operations and equipment. This International Standard does not purport to address all of the safety problems associated with its use. It is the responsibility of the user of this International Standard to establish appropriate safety and health practices and determine the applicability of regulatory limitations prior to use.

## 1 Scope

This International Standard specifies a method for the determination of the corrosiveness to copper of liquid petroleum products and certain solvents. Volatile products, having a maximum vapour pressure of 124 kPa at 37,8 °C are included.

Volatile products with a vapour pressure above 124 kPa at 37,8 °C should be tested according to ISO 6251 (see caution below). Electrical insulating oils should be tested according to ISO 5662.

**CAUTION** — Some products, particularly natural gasolines, may have a significantly higher vapour pressure than is characteristic for their class, even if below 124 kPa at 37,8 °C. For this reason, extreme caution should be exercised to ensure that the pressure vessel containing such material is not placed in a bath at 100 °C. Such samples may develop sufficient pressure at 100 °C to rupture the pressure vessel and cause damage and/or injury.

## 2 Normative references

The following standards contain provisions which, through reference in this text, constitute provisions of this International Standard. At the time of publication, the editions indicated were valid. All standards are subject to revision, and parties to agreements based on this International Standard are encouraged to investigate the possibility of applying the most recent editions of the standards indicated below. Members of IEC and ISO maintain registers of currently valid International Standards.

ISO 3170:1988, *Petroleum liquids — Manual sampling*.

ISO 3171:1988, *Petroleum liquids — Automatic pipeline sampling*.

## 3 Principle

A polished copper strip is immersed in a specified volume of sample and heated under conditions of temperature and time that are specific to the class of material being tested. Aviation fuels and natural gasolines are tested in a pressure vessel, and other products are tested under atmospheric pressure (see also the note in 8.1). At the end of the heating period, the strip is removed, washed, and the colour assessed against corrosion standards.

## 4 Reagents and materials

### 4.1 Wash solvent

2,2,4-trimethylpentane (isooctane) of minimum 99,75 % purity is the referee solvent, but any volatile sulfur-free hydrocarbon solvent that shows no tarnish when tested by the procedure of this International Standard for 3 h at 50 °C is suitable.

### 4.2 Polishing materials

**4.2.1 Silicon-carbide paper or cloth**, of varying degrees of fineness, including 65 µm (240 grit) grade.

**4.2.2 Silicon-carbide powder**, of 105 µm (150 mesh) size.

**4.2.3 Absorbent cotton (cotton wool)**.

NOTE — Commercial grade is suitable, but pharmaceutical grade is most commonly available.

## 5 Apparatus

**5.1 Copper strips**, cut from smooth-surfaced, hard temper, cold-finished electrolytic-type copper of more than 99,9 % purity; electrical busbar stock is generally suitable.

The strips shall be 75 mm ± 5 mm in length, 12,5 mm ± 2 mm in width, and 1,5 mm to 3,0 mm in thickness.

When the strips show pitting or deep scratches that cannot be removed by the specified polishing procedure, or when the surfaces become deformed on handling, they shall be discarded.

**5.2 Pressure vessel**, constructed of stainless steel and of the dimensions shown in figure 1.

The vessel shall be capable of withstanding a test pressure of 700 kPa gauge.

NOTE — Alternative designs for the vessel cap and synthetic rubber gasket may be used, provided that the internal dimensions of the vessel are the same as those shown in figure 1.

**5.3 Test tubes**, of borosilicate glass, of nominal 25 mm x 150 mm.

The internal dimensions shall be checked with a metal strip of the maximum length given in 5.1 and not more than the median dimensions for width and thickness. When 30 ml of liquid is added, a minimum of 5 mm shall be above the top surface of the strip.

### 5.4 Test baths

#### 5.4.1 General

All test baths shall have sufficient heat capacity to raise the product temperature to within ± 1 °C of the test temperature within 15 min.

**5.4.2 Liquid bath for pressure vessel**, capable of maintaining the product at the specified test temperature ± 1 °C.

The bath shall be constructed of non-transparent material and shall be deep enough to submerge one or more pressure vessels (5.2) completely during the test. It shall be fitted with suitable supports to hold each pressure vessel in a vertical position when submerged.

**5.4.3 Bath for test tubes**, capable of maintaining the product at the specified test temperature  $\pm 1^\circ\text{C}$ .

Liquid baths shall be constructed of non-transparent material, and shall be fitted with suitable supports to hold each test tube (5.3) in a vertical position to a depth of  $100\text{ mm} \pm 5\text{ mm}$ . Solid block baths shall meet the same temperature control and immersion conditions, and shall be checked for temperature measurement (heat transfer) for each product class, by running tests on tubes filled with 30 ml of product plus a metal strip of the nominal dimensions given in 5.1, plus a temperature sensor.

**5.5 Temperature sensor**, for indicating the test temperature.

For liquid baths, a total immersion liquid-in-glass thermometer is suitable, with graduations of  $1^\circ\text{C}$  or less. It shall be submerged in the liquid such that not more than 25 mm of the thread extends above the liquid surface.

NOTE — The ASTM 12C/IP 64C thermometer is suitable.

**5.6 Polishing vice or holder**, for holding copper strips firmly without marring the edges while polishing.

The strip shall be held tightly, and the surfaces of the strip that is being polished shall be supported above the surface of the holder.

NOTE — A suitable apparatus is illustrated in figure 2.

**5.7 Viewing test tubes**, for protecting corroded copper strips during close inspection or during storage, of such dimensions to allow the introduction of a copper strip (5.1) and made of glass which is free of striae or similar defects.

NOTE — A suitable "flat" tube is illustrated in figure 3.

**5.8 Forceps**, spade-ended, with either stainless steel or polytetrafluoroethylene (PTFE) tips.

**5.9 Corrosion standards**<sup>1)</sup>, for the evaluation of tarnish at the end of the test.

Further details on the composition and maintenance of these standards are given for information in annex A.

**5.10 Timing device**, electronic or manual, accurate to 1,0 s.

## 6 Samples and sampling

**6.1** Unless otherwise specified, samples shall be taken according to the procedures described in ISO 3170 or ISO 3171.

**6.2** Samples that are required to be tested against a "low-tarnish" strip classification shall be collected in clean, dark-glass bottles, or other suitable containers that will not affect the corrosive properties of the liquid. Appropriate plastic containers are suitable for some low-volatility products, but not for gasolines. Avoid the use of tinplate containers for samples, since they may contribute to sample corrosiveness.

**6.3** Fill the container as completely as possible and close it immediately after sampling. Take care to protect the sample from direct sunlight, or even diffused daylight. Carry out the test as soon as possible after receipt, and immediately after opening the container.

**6.4** If suspended water (haze) is observed in the test sample, or when filling the test tube (5.3), dry the sample by filtering a sufficient volume of it through a medium rapidity qualitative filter paper into a clean, dry test tube. Carry out this operation in a darkened room or under a light-protected shield.

NOTE — Contact of the copper strip with water before, during, or after the completion of the test period will cause staining, making it difficult to evaluate the strips.

1) Available from ASTM, 100 Barr Harbor Drive, West Conshohocken, PA 19428-2959, USA.

## 7 Preparation of test strips

### 7.1 Surface preparation

Remove all surface blemishes from all six sides of the copper strip (5.1) with silicon-carbide paper or cloth (4.2.1) of such degrees of fineness as are needed to achieve the desired results efficiently. Finish with 65  $\mu\text{m}$  silicon-carbide paper or cloth, removing all marks that may have been made by other grades of paper or cloth used previously. Immerse the copper strip in wash solvent (4.1). Withdraw immediately for final polishing, or store for future use.

For manual surface preparation, place a sheet of the abrasive paper or cloth on a flat surface, moisten it with the wash solvent and rub the copper strip against the paper or cloth with a rotary motion, protecting the strip from contact with the fingers with an ashless filter paper. Alternatively, prepare the surface of the copper strip by means of motor-driven machines, using appropriate grades of dry paper or cloth.

### 7.2 Final polishing

Remove a strip from the wash solvent. Holding it in the fingers protected by ashless filter paper, polish first the ends and then the sides with the 105  $\mu\text{m}$  silicon-carbide powder (4.2.2) picked up from a clean glass plate with a wad of absorbent cotton (4.2.3) moistened with a drop of wash solvent. Wipe vigorously with fresh pads of absorbent cotton and subsequently handle only with forceps (5.8). **Do not touch the strip with the fingers.** Clamp in the vice (5.6) and polish the main surfaces with silicon-carbide powder on absorbent cotton. Rub in the direction of the long axis of the copper strip, carrying the stroke beyond the end of the strip before reversing the direction. Clean all metal dust from the strip by rubbing vigorously with clean pads of absorbent cotton until a fresh pad remains unsoiled. When the strip is clean, immediately immerse it in the prepared sample.

It is important to polish the whole surface of the strip uniformly to obtain a uniformly stained strip. If the edges show wear (surfaces elliptical), they will be likely to show more corrosion than the centre of the strip. The use of a vice will facilitate uniform polishing.

## 8 Procedure

### 8.1 General

There are a variety of test conditions which are broadly specific to given classes of product, but within certain classes, more than one condition of time and/or temperature may apply. In general, aviation fuels shall be tested in a pressure vessel at 100 °C, and natural gasolines at 40 °C. Other liquid products shall be tested in a test tube at 50 °C, 100 °C or even higher temperatures.

NOTE — These conditions apply to the most commonly used specifications, but other conditions may be set by specification bodies or agreement between parties.

### 8.2 Pressure vessel procedure

Place a 30 ml test portion, completely clear and free of any suspended or entrained water (see the note in 6.4) in a chemically clean, dry test tube (5.3). Within 1 min after completing the final polishing, slide the copper strip into the test portion in the test tube. Carefully slide the test tube into the pressure vessel (5.2) and screw the lid on tight. Completely immerse the pressure vessel in the liquid bath (5.4.2) maintained at the test temperature  $\pm 1$  °C. At the end of the specified test period  $\pm 5$  min, withdraw the pressure vessel from the liquid bath and immerse it for a few minutes in cool water. Open the pressure vessel, withdraw the test tube, and follow the procedure in 8.4.

### 8.3 Test tube procedure

Place a 30 ml test portion, completely clear and free from any suspended or entrained water (see the note in 6.4) in a chemically clean, dry test tube (5.3). Within 1 min after completing final polishing, slide the copper strip into the test portion in the test tube. Stopper with a vented cork, and place the test tube in the test bath (5.4.2) maintained at the test temperature  $\pm 1$  °C. At the end of the specified test period  $\pm 5$  min, remove the test tube and follow the

procedure in 8.4. If, at the end of the test period, the level of the liquid in the test tube has fallen below any portion of the copper strip, discard, and repeat the test using a 35 ml test portion.

NOTE — Some automotive gasolines with vapour pressures above 80 kPa at 37,8 °C have exhibited evaporation losses in excess of 10 % of their volume.

#### 8.4 Strip examination

Empty the contents of the test tube into a suitably-sized beaker, such as a 150 ml tall-form, letting the copper strip slide in gently so as to avoid breaking the beaker. Immediately withdraw the strip with the forceps (5.8) and immerse it in wash solvent (4.1). Withdraw the strip at once, dry with quantitative filter paper (by blotting and not by wiping), and inspect for evidence of tarnishing or corrosion by comparison with the corrosion standards (5.9). Hold both the test strip and the standards in such a manner that light reflected from them at an angle of approximately 45° will be observed.

NOTE — In handling the test strip during the inspection and comparison, the danger of marking or staining can be avoided if it is inserted in the viewing tube (5.7), which is stoppered with absorbent cotton (4.2.3).

### 9 Interpretation of results

9.1 Interpret the corrosiveness of the test portion in accordance with one of the classifications for the corrosion standards as listed in table 1.

9.2 When a strip is in the obvious transition state between that indicated by any two adjacent standards, judge the sample by the more tarnished standard. Should a strip appear to have a darker orange colour than standard 1b, consider the observed strip as still belonging in classification 1; however, if any evidence of red colour is observed, the observed strip belongs in classification 2.

9.3 A claret red strip in classification 2 can be mistaken for a magenta overcast on brassy strip in classification 3 if the brassy underlay of the latter is completely masked by a magenta overtone. To distinguish between the two, immerse the strip in wash solvent (4.1); the former will appear as a dark orange while the latter will not change.

9.4 To distinguish between multicoloured strips in classifications 2 and 3, place the test strip in a test tube (5.3) and bring it to a temperature of 340 °C ± 30 °C in 4 min to 6 min with the tube lying on a hotplate. Adjust the temperature while observing a high-range distillation thermometer in a second test tube. If the strip belongs in classification 2, it will assume the colour of a silver and then a gold strip. If the strip belongs in classification 3, it will take on the appearance of a transparent black, as described in classification 4a.

9.5 Repeat the test if blemishes are observed due to fingerprints or to spots from any particles or water droplets that may have touched the test strip during the digestion period.

9.6 Repeat the test if the sharp edges along the flat faces of the strip appear to be in a classification higher than the greater portion of the strip.

NOTE — In this case, it is likely that the edges were burnished during polishing.

### 10 Expression of results

Report the classification number in accordance with the descriptions in table 1, together with the time and temperature of the test, in the form:

Corrosion copper strip ( $X$  h/ $Y$  °C), Class  $Z$

Specifications limiting the maximum tarnish level to classification 1, should **not** indicate "maximum", since there is no other satisfactory level reportable.

NOTE — Reporting of descriptive classifications is informative only, as these do not represent intermediate corrosion levels, merely alternative appearances for similar corrosivity. Limiting values cannot be set at one of these descriptions.

**Table 1 — Classification of corrosion standards**

Classification	Designation	Description <sup>1)</sup>
Freshly polished strip	—	— <sup>2)</sup>
1	Slight tarnish	a Light orange, almost the same as a freshly polished strip b Dark orange
2	Moderate tarnish	a Claret red b Lavender c Multicoloured with lavender blue and/or silver overlaid on claret red d Silvery e Brassy or gold
3	Dark tarnish	a Magenta overcast on brassy strip b Multicoloured with red and green showing (peacock), but no grey
4	Corrosion	a Transparent black, dark grey or brown with peacock green barely showing b Graphite or lustreless black c Glossy or jet black
<p>1) The corrosion standard is made up of strips characteristic of these descriptions. 2) The freshly polished strip is included in the series only as an indication of the appearance of a properly polished strip before a test run. It is not possible to duplicate this appearance after a test run with a completely non-corrosive sample.</p>		

## 11 Precision

The test method is essentially a pass/fail procedure, and no generally acceptable method for determining precision is currently available.

## 12 Test report

The test report shall contain at least the following information:

- a) a reference to this International Standard;
- b) all details necessary for complete identification of the product tested;
- c) the result of the test (see clause 10);
- d) any deviation, by agreement or otherwise, from the procedure specified;
- e) the date of the test.

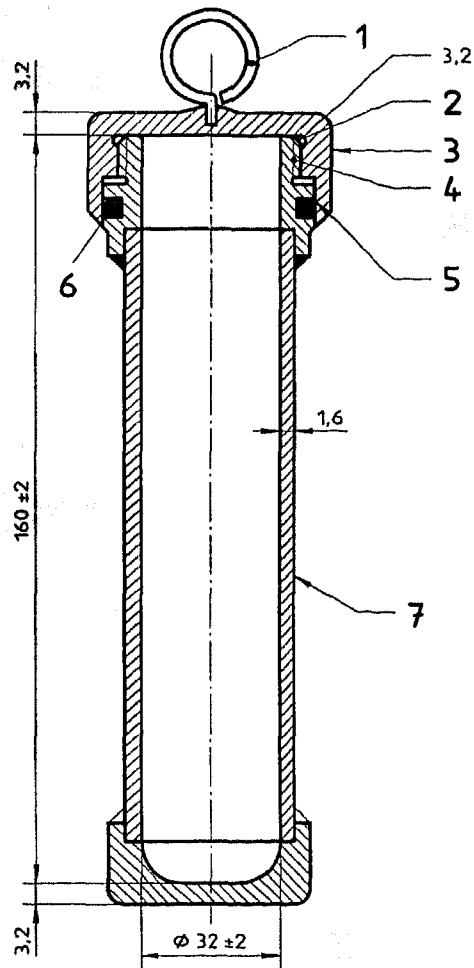

Dimensions in millimetres

**Key**

- 1 Lifting eye
- 2 Wide groove for pressure relief
- 3 Knurled cap
- 4 Twelve threads per inch NF thread or equivalent
- 5 Chamfer inside cap to protect "O" ring when closing pressure vessel
- 6 Synthetic rubber "O" ring without free sulfur
- 7 Seamless tube

Material: stainless steel

Welded construction

Maximum test gauge pressure: 700 kPa

**Figure 1 — Pressure vessel for copper strip corrosion test**

Dimensions in millimetres

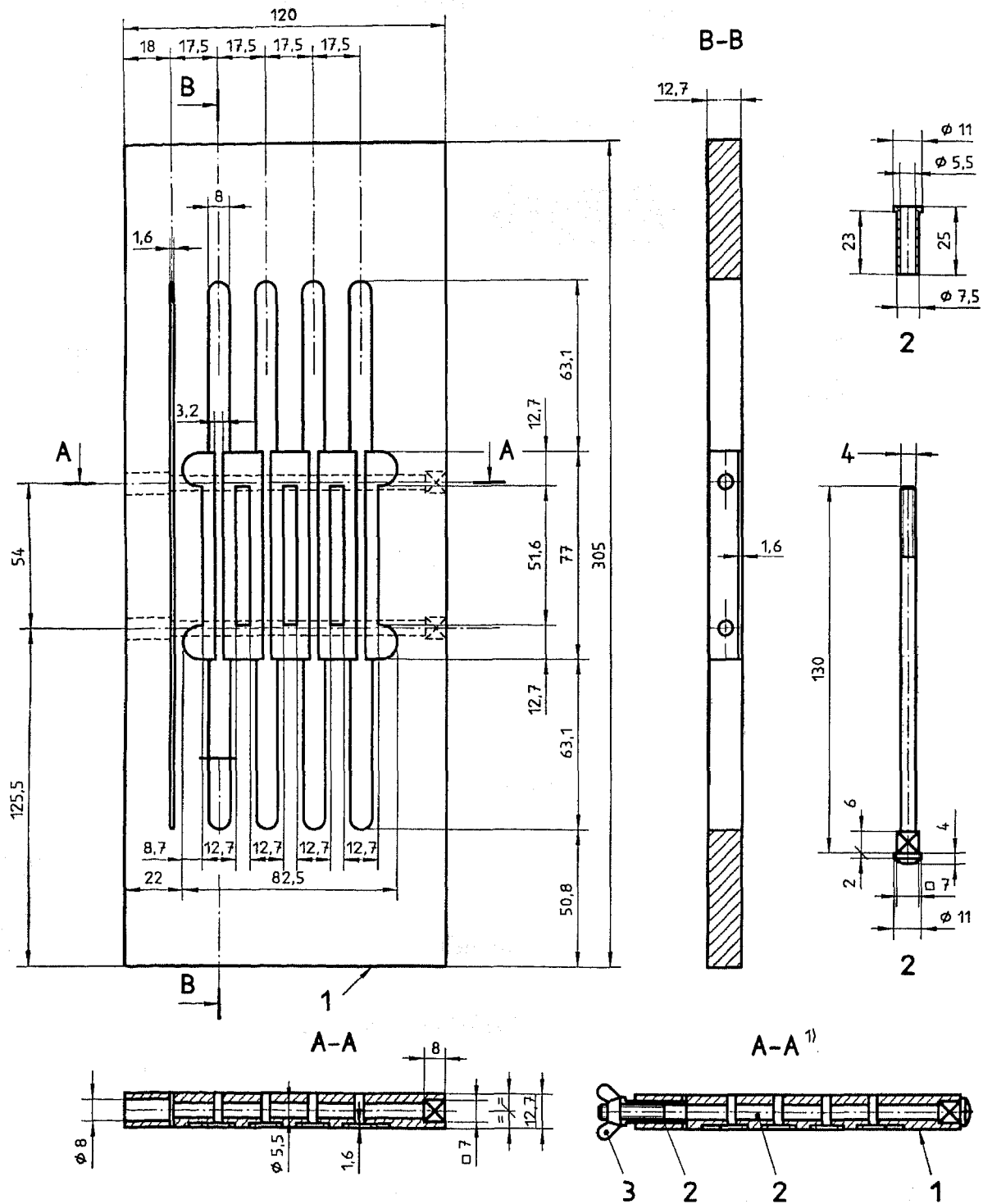

**Key**

- 1 Material: plastic
  - 2 Material: brass
  - 3 Wing nut
  - 4  $\varnothing$  5 mm metric thread or equivalent
- 1) With screw

Figure 2 — Multistrip vice

Dimensions in millimetres

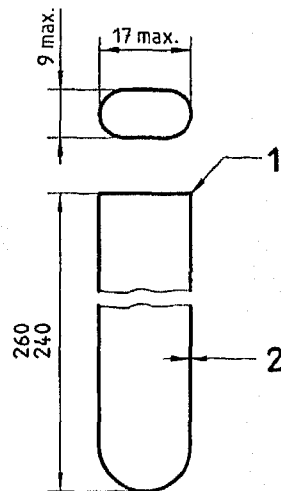
**Key**

- 1 Fire polished
- 2 Thickness 0,75 mm to 1,05 mm

**NOTES**

- 1 The dimensions indicated are the minimum dimensions that shall allow the introduction of a copper strip (5.1).
- 2 The tube shall be free of striae or similar defects.

**Figure 3 — Viewing test tube**

## Annex A (informative)

### Corrosion standards

#### A.1 Description

The corrosion standards for this test consist of full-colour reproductions, printed on aluminium sheets by a four-colour process of typical test strips representing increasing degrees of tarnish and corrosion (see table 1). The reproductions are encased for protection in plastics in the form of a plaque. Directions for their use are given on the reverse side of each plaque.

#### A.2 Maintenance

**A.2.1** The plastics-encased corrosion standards should be protected from light to avoid the possibility of fading. They should be inspected for fading by comparing two different plaques, one of which has been carefully protected from light (new plaque). Both sets should be observed in diffused daylight (or equivalent), first from a point directly above and then from an angle of 45°. If any evidence of fading is observed, particularly at the left-hand end of the plaque, it is suggested that the plaque be discarded.

**A.2.2** Alternatively, a 20 mm opaque strip (masking tape) should be placed across the top of the colour portion of the plaque when initially purchased. At intervals, the opaque strip should be removed and the plaque examined for any evidence of fading of the exposed portion. If any fading has occurred, it is suggested that the corrosion standard be replaced.

**A.2.3** If the surface of the plastic cover shows excessive scratching, it is suggested that the corrosion standard be replaced.

**Annex B**  
(informative)

**Bibliography**

- [1] ISO 5662:1997, *Petroleum products — Electrical insulating oils — Detection of corrosive sulfur.*
- [2] ISO 6251:1996, *Liquefied petroleum gases — Corrosiveness to copper — Copper strip test.*

---

---

**ICS 75.080**

**Descriptors:** petroleum products, determination, corrosivity, corrosion tests, copper products.

Price based on 11 pages

---

---