**Slotted countersunk flat head screws —
Product grade A**

Vis à métaux à tête fraisée fendue — Grade A



Reference number
ISO 2009:2011(E)

© ISO 2011



COPYRIGHT PROTECTED DOCUMENT

© ISO 2011

All rights reserved. Unless otherwise specified, no part of this publication may be reproduced or utilized in any form or by any means, electronic or mechanical, including photocopying and microfilm, without permission in writing from either ISO at the address below or ISO's member body in the country of the requester.

ISO copyright office
Case postale 56 • CH-1211 Geneva 20
Tel. + 41 22 749 01 11
Fax + 41 22 749 09 47
E-mail copyright@iso.org
Web www.iso.org

Published in Switzerland

Foreword

ISO (the International Organization for Standardization) is a worldwide federation of national standards bodies (ISO member bodies). The work of preparing International Standards is normally carried out through ISO technical committees. Each member body interested in a subject for which a technical committee has been established has the right to be represented on that committee. International organizations, governmental and non-governmental, in liaison with ISO, also take part in the work. ISO collaborates closely with the International Electrotechnical Commission (IEC) on all matters of electrotechnical standardization.

International Standards are drafted in accordance with the rules given in the ISO/IEC Directives, Part 2.

The main task of technical committees is to prepare International Standards. Draft International Standards adopted by the technical committees are circulated to the member bodies for voting. Publication as an International Standard requires approval by at least 75 % of the member bodies casting a vote.

Attention is drawn to the possibility that some of the elements of this document may be the subject of patent rights. ISO shall not be held responsible for identifying any or all such patent rights.

ISO 2009 was prepared by Technical Committee ISO/TC 2, *Fasteners*, Subcommittee SC 11, *Fasteners with metric external thread*.

This fourth edition cancels and replaces the third edition (ISO 2009:1994), of which it constitutes a minor revision.

Slotted countersunk flat head screws — Product grade A

1 Scope

This International Standard specifies the characteristics of slotted countersunk flat head screws of product grade A and with threads from M1,6 to M10 inclusive.

If, in special cases, specifications other than those listed in this International Standard are required, they can be selected from existing International Standards, for example ISO 261, ISO 888, ISO 898-1, ISO 965-2 and ISO 3506-1.

2 Normative references

The following referenced documents are indispensable for the application of this document. For dated references, only the edition cited applies. For undated references, the latest edition of the referenced document (including any amendments) applies.

ISO 225, *Fasteners — Bolts, screws, studs and nuts — Symbols and descriptions of dimensions*

ISO 261, *ISO general purpose metric screw threads — General plan*

ISO 898-1, *Mechanical properties of fasteners made of carbon steel and alloy steel — Part 1: Bolts, screws and studs with specified property classes — Coarse thread and fine pitch thread*

ISO 965-2, *ISO general purpose metric screw threads — Tolerances — Part 2: Limits of sizes for general purpose external and internal screw threads — Medium quality*

ISO 3269, *Fasteners — Acceptance inspection*

ISO 3506-1, *Mechanical properties of corrosion-resistant stainless steel fasteners — Part 1: Bolts, screws and studs*

ISO 4042, *Fasteners — Electroplated coatings*

ISO 4759-1, *Tolerances for fasteners — Part 1: Bolts, screws, studs and nuts — Product grades A, B and C*

ISO 6157-1, *Fasteners — Surface discontinuities — Part 1: Bolts, screws and studs for general requirements*

ISO 8839, *Mechanical properties of fasteners — Bolts, screws, studs and nuts made of non-ferrous metals*

ISO 8992, *Fasteners — General requirements for bolts, screws, studs and nuts*

ISO 10683, *Fasteners — Non-electrolytically applied zinc flake coatings*

ISO 16048, *Passivation of corrosion-resistant stainless-steel fasteners*

3 Dimensions

See Figure 1 and Table 1. Symbols and descriptions of dimensions are specified in ISO 225.

The shank diameter is approximately equal to the pitch diameter or equal to the permissible major thread diameter.

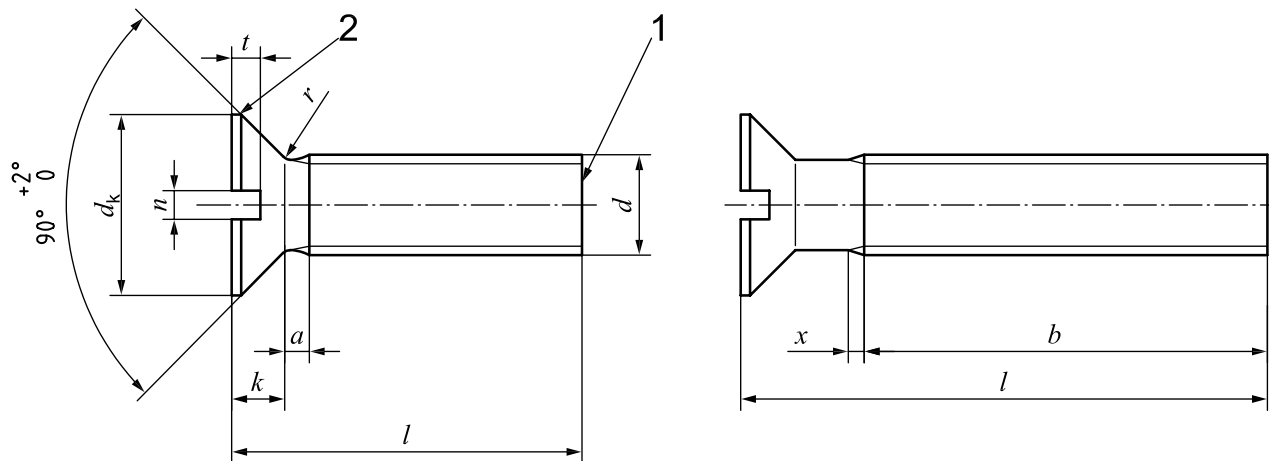

Key

- 1 as-rolled end
- 2 edge (rounded or flat)

Figure 1

Table 1 — Dimensions

Dimensions in millimetres

Thread, <i>d</i>		M1,6	M2	M2,5	M3	(M3,5) ^a	M4	M5	M6	M8	M10	
<i>p</i> ^b		0,35	0,4	0,45	0,5	0,6	0,7	0,8	1	1,25	1,5	
<i>a</i>	max.	0,7	0,8	0,9	1	1,2	1,4	1,6	2	2,5	3	
<i>b</i>	min.	25	25	25	25	38	38	38	38	38	38	
<i>d_k</i> ^c	Theoretical	max.	3,6	4,4	5,5	6,3	8,2	9,4	10,4	12,6	17,3	20
	Actual	nom. = max.	3,0	3,8	4,7	5,5	7,30	8,40	9,30	11,30	15,80	18,30
		min.	2,7	3,5	4,4	5,2	6,94	8,04	8,94	10,87	15,37	17,78
<i>k</i> ^c	nom. = max.	1	1,2	1,5	1,65	2,35	2,7	2,7	3,3	4,65	5	
<i>n</i>	nom.	0,4	0,5	0,6	0,8	1	1,2	1,2	1,6	2	2,5	
	max.	0,60	0,70	0,80	1,00	1,20	1,51	1,51	1,91	2,31	2,81	
	min.	0,46	0,56	0,66	0,86	1,06	1,26	1,26	1,66	2,06	2,56	
<i>r</i>	max.	0,4	0,5	0,6	0,8	0,9	1	1,3	1,5	2	2,5	
<i>t</i>	max.	0,50	0,6	0,75	0,85	1,2	1,3	1,4	1,6	2,3	2,6	
	min.	0,32	0,4	0,50	0,60	0,9	1,0	1,1	1,2	1,8	2,0	
<i>x</i>	max.	0,9	1	1,1	1,25	1,5	1,75	2	2,5	3,2	3,8	
<i>l_{ad}</i>			Approximate mass, in kilograms per 1 000 pieces ($\rho = 7,85 \text{ kg/dm}^3$) (for information only)									
nom.	min.	max.										
2,5	2,3	2,7	0,053									
3	2,8	3,2	0,058	0,101								
4	3,76	4,24	0,069	0,119	0,206							
5	4,76	5,24	0,081	0,137	0,236	0,335						
6	5,76	6,24	0,093	0,152	0,266	0,379	0,633	0,903				
8	7,71	8,29	0,116	0,193	0,326	0,467	0,753	1,06	1,48	2,38		
10	9,71	10,29	0,139	0,231	0,386	0,555	0,873	1,22	1,72	2,73	5,68	
12	11,65	12,35	0,162	0,268	0,446	0,643	0,933	1,37	1,96	3,08	6,32	9,54
(14)	13,65	14,35	0,185	0,306	0,507	0,731	1,11	1,53	2,2	3,43	6,96	10,6
16	15,65	16,35	0,208	0,343	0,567	0,82	1,23	1,68	2,44	3,78	7,6	11,6
20	19,58	20,42		0,417	0,687	0,996	1,47	2	2,92	4,48	8,88	13,6
25	24,58	25,42			0,838	1,22	1,77	2,39	3,52	5,36	10,5	16,1
30	29,58	30,42				1,44	2,07	2,78	4,12	6,23	12,1	18,7
35	34,5	35,5					2,37	3,17	4,72	7,11	13,7	21,2
40	39,5	40,5						3,56	5,32	7,98	15,3	23,7
45	44,5	45,5							5,92	8,86	16,9	26,2
50	49,5	50,5							6,52	9,73	18,5	28,8

Table 1 (continued)

Dimensions in millimetres

Thread, d			M1,6	M2	M2,5	M3	(M3,5) ^a	M4	M5	M6	M8	M10
l^{ad}			Approximate mass, in kilograms per 1 000 pieces ($\rho = 7,85 \text{ kg/dm}^3$) (for information only)									
nom.	min.	max.										
(55)	54,05	55,95								10,6	20,1	31,3
60	59,05	60,95								11,5	21,7	33,8
(65)	64,05	65,95									23,3	36,3
70	69,05	70,95									24,9	38,9
(75)	74,05	75,95									26,5	41,4
80	79,05	80,95									28,1	43,9
NOTE Preferred lengths are those between the solid, bold, stepped lines.												
<p>^a Sizes in parentheses should be avoided if possible.</p> <p>^b P is the pitch of the thread.</p> <p>^c See ISO 7721.</p> <p>^d Screws with nominal lengths above the bold, discontinuous line are threaded up to the head; $b = l - (k + a)$.</p>												

4 Specifications and reference International Standards

See Table 2.

Table 2 — Specifications and reference International Standards

Material		Steel	Stainless steel	Non-ferrous metal
General requirements	International Standard	ISO 8992		
	Tolerance class	6g		
Thread	International Standard	ISO 261, ISO 965-2		
	Property class	4.8, 5.8	A2-50, A2-70	—
Mechanical property	International Standard	ISO 898-1	ISO 3506-1	ISO 8839
	Product grade	A		
Tolerance	International Standard	ISO 4759-1		
	Finish — Coating	As processed		
Requirements for electroplating are specified in ISO 4042.		Requirements for passivation are specified in ISO 16048.	Requirements for electroplating are specified in ISO 4042.	
		Requirements for non-electrolytically applied zinc flake coatings are specified in ISO 10683.		
		Additional requirements or other finishes or coatings shall be agreed between the supplier and the purchaser.		
Surface integrity		Limits for surface discontinuities are specified in ISO 6157-1.		
Acceptability		Acceptance inspection is specified in ISO 3269.		

5 Designation

EXAMPLE A slotted countersunk flat head screw with thread M5, nominal length $l = 20$ mm and property class 4.8 is designated as follows:

Countersunk flat head screw ISO 2009 - M5 × 20 - 4.8

Bibliography

- [1] ISO 888, *Bolts, screws and studs — Nominal lengths, and thread lengths for general purpose bolts*
- [2] ISO 7721, *Countersunk head screws — Head configuration and gauging*

ICS 21.060.10

Price based on 6 pages