

# International Standard



# 1995

W-73-62

---

INTERNATIONAL ORGANIZATION FOR STANDARDIZATION • МЕЖДУНАРОДНАЯ ОРГАНИЗАЦИЯ ПО СТАНДАРТИЗАЦИИ • ORGANISATION INTERNATIONALE DE NORMALISATION

---

## Aromatic hydrocarbons — Sampling

*Hydrocarbures aromatiques — Échantillonnage*

First edition — 1981-11-01

## Foreword

ISO (the International Organization for Standardization) is a worldwide federation of national standards institutes (ISO member bodies). The work of developing International Standards is carried out through ISO technical committees. Every member body interested in a subject for which a technical committee has been set up has the right to be represented on that committee. International organizations, governmental and non-governmental, in liaison with ISO, also take part in the work.

Draft International Standards adopted by the technical committees are circulated to the member bodies for approval before their acceptance as International Standards by the ISO Council.

International Standard ISO 1995 was developed by Technical Committee ISO/TC 78, *Aromatic hydrocarbons*, and was circulated to the member bodies in November 1979.

It has been approved by the member bodies of the following countries :

Australia	Hungary	Netherlands
Austria	India	Philippines
Chile	Italy	Poland
Czechoslovakia	Japan	South Africa, Rep. of
France	Korea, Rep. of	USSR
Germany, F. R.	Mexico	

The member body of the following country expressed disapproval of the document on technical grounds :

United Kingdom

# Aromatic hydrocarbons — Sampling

## 0 Introduction

This International Standard is one of a series dealing with the sampling, testing and specification of aromatic hydrocarbons.

As most aromatic hydrocarbons are similar to petroleum products, many of the sampling procedures used for the latter are equally applicable to the former. Hence, parts of the text in this International Standard are identical with that in ISO 3170, *Petroleum products — Liquid hydrocarbons — Manual sampling*. Similarly, as all aromatic hydrocarbons are flammable, and most of them are toxic, the relevant safety precautions described in ISO 3165, *Sampling of chemical products for industrial use — Safety in sampling*, have also been incorporated.

## 1 Scope and field of application

**1.1** This International Standard specifies sampling procedures to be used for obtaining samples of liquid aromatic hydrocarbons from fixed tanks, railcars, road vehicles, barges and drums, or from liquids being pumped in pipelines.

**1.2** The samples taken by the procedures specified are intended to be used to determine :

- a) quality;
- b) whether contaminants are present;
- c) the degree of homogeneity of a batch.

The information obtained may be used for either qualitative or quantitative assessment of the batch being sampled.

**1.3** When a batch of materials is to be received or consigned, there are often the alternative possibilities of sampling from a tank or from a pipeline during the transfer operation.

Pipeline sampling, manual or automatic, as distinct from tank sampling, is generally used for the following reasons :

- a) when the contents of a tank are likely to suffer from a marked lack of homogeneity, including the presence of two layers with different densities;
- b) for monitoring material that is being pumped through a pipeline;

- c) for monitoring the performance of in-line blending systems, and for determining the properties of a batch of product being made with an in-line blending system.

It is often necessary to employ both tank and pipeline sampling covering particular operations.

**1.4** Pipeline sampling may be manual or automatic.

For automatic pipeline sampling, reference should be made to ISO 3171.

Automatic procedures should be employed if there is a possibility that the liquid flowing through the pipeline is non-homogeneous.

## 2 References

ISO 2859, *Sampling procedures and tables for inspection by attributes*.

ISO 3171, *Petroleum products — Liquid hydrocarbons — Automatic pipeline sampling*.

## 3 Definitions

**3.1 aromatic hydrocarbons** : Benzene and its homologues, pure or commercially pure, isolated or in mixtures, and whether or not containing impurities in a substantial proportion, provided that the aromatic-type products predominate in the bulk of the product.

### 3.2 Terms related to samples

**3.2.1 sample** : One or more items taken from a population and intended to provide information on the population and possibly to serve as a basis for a decision on the population or on the process which had produced it.

**3.2.2 representative sample** : A sample assumed to have the same composition as the material sampled when the latter is considered as a homogeneous whole.

**3.2.3 bulk sample; gross sample** : The total material obtained by the sampling procedure.

**3.2.4 spot sample** : A sample of specified number or size taken from a specified place in the material or at a specified place and time in a stream of material and representative of its own immediate or local environment.

NOTE — In English, the term "snap sample" is sometimes used as a synonym of "spot sample".

**3.2.5 composite sample** : A sample taken by combining representative samples from a number of tanks or containers in amounts proportional to the contents of each of the tanks or containers.

**3.2.6 continuous sample** : A sample taken continuously from a stream of material.

**3.2.7 final sample** : A sample obtained or prepared under the sampling plan for possible subdivision into identical portions for testing, reference or storage.

**3.2.8 laboratory sample** : A sample as prepared for sending to the laboratory and intended for inspection or testing.

**3.2.9 test sample** : A sample prepared from the laboratory sample and from which test portions will be taken.

### 3.3 Terms related to the statistics of sampling

**3.3.1 true value** : Value of a characteristic of the material perfectly defined in the conditions which exist at the moment when that characteristic is the subject of a determination.

It is an ideal value which could be arrived at only if all causes of measurement error could be eliminated.

**3.3.2 average lot quality** : The result that would theoretically be obtained by taking the average of results from a large number of laboratories, of replicate determinations of a characteristic, by the test method in question, made on replicate representative samples taken from the lot.

**3.3.3 variability** : The differences throughout the material in the value of a characteristic.

**3.3.4 homogeneous material** : Material is said to be homogeneous in relation to a given characteristic if the mean values of that characteristic for the different fractions which make up the material are, for that characteristic, within the limits of error for the measurement made to determine that characteristic.

NOTE — A distinction should be made between

- a) the *constitution heterogeneity*, which is due to difference in the composition between the different portions (for example the particles) constituting the material; and
- b) the *repartition heterogeneity*, which is due to differences in the localization of the different portions constituting the material. This heterogeneity disappears if the portions are mixed (it may then be transformed into constitution heterogeneity).

**3.3.5 heterogeneous material** : Material which is not homogeneous (see 3.3.4).

**3.3.6 defect** : Any non-compliance of a sampling unit with specified requirements for the value of a characteristic.

**3.3.7 defective unit; defective item** : A sampling unit containing one or more defects.

**3.3.8 accuracy** : The closeness of agreement between the true value and the mean of test results which would be obtained by carrying out determination of the characteristic a very large number of times.

NOTE — The smaller the systematic part of the experimental errors which affect the results, the more accurate is the determination.

**3.3.9 precision** : The closeness of agreement between the results obtained for a given characteristic by carrying out the determination several times under prescribed conditions.

NOTE — The smaller the random part of the experimental errors which affect the results, the more precise is the determination.

**3.3.10 sampling error** : That part of the total estimation error of a parameter due to the random nature of the sample.

## 4 General recommendations

**4.1** The following recommendations apply to all sampling operations whatever the nature of the material being sampled. The operator should have :

- safe access to and from the place where the sample is taken, and
- a safe working place with adequate light and ventilation.

Sampling points in fixed installations should be arranged to satisfy these needs as well as any special conditions arising from the nature of the material being sampled. Precautions shall be taken against falls when the sample is withdrawn from the top of a tank or tank vehicle and against the collapse of stacked containers or solids in bulk.

**4.2** The sampling operation shall be carried out in such a manner as not to prejudice the security of the bulk.

This applies particularly to the sampling of fluids through cocks where the seizure of the cock in an open position could lead to the escape of large quantities of the fluid. It is recommended that the devices used for such sampling be arranged so as to limit the total quantity drawn at any one time and to restrict the rate of flow to a convenient value.

It is reasonable to assume that spillages will occur and to provide both a drained trough and a tundish to trap spilt liquids safely and a permanent splash guard to protect the sampler.

Provision shall be made whenever possible for isolating the sampling point from the bulk or line by a valve near to, but not

immediately adjacent to, the sampling point so that in the event of an accident the flow may be controlled from a safe place.

In all cases it is part of the sampler's task to ensure satisfactory re-closure by appropriate personnel of all opened packages and sampling points.

**4.3** When it is necessary to purge or rinse a sample container with the material to be sampled, and this material presents a hazard, then appropriate facilities shall be provided for the disposal of material used in purging. Vapours should be vented away from the vicinity of the sampler and other personnel.

**4.4** The size of the sample and the frequency of sampling shall not be greater than are necessary for the examination proposed.

**4.5** The sample in its container shall be carried in a suitable carrier designed and constructed to facilitate handling and to minimize the risk and consequences of breakage of the sample container.

**4.6** The equipment, including all tools and containers, shall be compatible with the material being sampled and suitable for the intended purpose.

Samples shall be kept away from other chemical products liable to interact with them.

**4.7** Before sampling, or as soon as possible, mark the container to indicate the nature of the material and the risks associated with it.

**4.8** The person taking the sample shall be made fully aware of the nature of the hazards involved and the precautions to be taken. He shall be instructed in the use of all appliances provided for his safety, including fire extinguishers, protective goggles and clothing, etc. He shall be instructed to report to an appropriate supervisor before and after taking the sample and shall report, preferably to the same authority, any unusual happening or situation.

If toxic substances are being sampled, he shall be instructed that, in the event of feeling unwell, he should report immediately to his supervisor.

**4.9** The sampler should be accompanied by a second person whose task is to ensure the safety of the sampler. During the sampling operation this observer shall remain well clear of the sampling point and observe the whole operation. He shall be given specific instructions as to the action he shall take in an emergency and such instructions should always require that he first raises an alarm and does not attempt a single-handed rescue, except in extreme circumstances.

**4.10** These general recommendations and the specific ones which follow should be used as a guide to the precautions necessary in preparing all samples.

**4.11** Eye protection equipment should be used continuously wherever there is contact with chemicals.

**4.12** It is stressed that those directing the activities of samplers shall consider in detail the consequences of minor mishaps which may occur, such as spillage, failure of cocks, etc. The sampler shall be given specific instructions covering both the normal situation and what he must do in the event of mishaps. Equally important are the specific instructions to be given to the safety observer present when toxic materials are sampled (see 5.2).

## 5 Specific recommendations for hazardous materials

The physical and chemical properties of aromatic hydrocarbons are such that they can have a direct physiological effect or be such that, for example, fire or explosion risks are present. The degree of risk is extremely variable and only general guidance is possible. A general classification of risks is listed below together with the appropriate precautions which are additional to those given in 4.2.

Many materials present more than one hazard; for example benzene is toxic and flammable and its vapour forms an explosive mixture with air.

Further information on individual substances is given in the following publications :

- *Substances chimiques dangereuses et proposition concernant leur étiquetage*. Conseil de l'Europe (Sous-comité de la santé et sécurité industrielle) — (Section chimie), Strasbourg, 3<sup>ème</sup> édition 1971.
- *Dangerous properties of industrial materials*, by N. Irving Sax. Published by Van Nostrand Reinhold Company.
- *Toxicity and metabolism of industrial solvents*, by Ethel Browning. Published by Elsevier.
- *Hazards in the chemical laboratory*, Ed. by G. D. Muir. Published by Royal Institute of Chemistry.
- *The care, handling and disposal of dangerous chemicals*, by P. J. Gaston. Published by the Institute of Science Technology.

The following types of hazard may be encountered :

- flammable substances (see 5.1);
- toxic substances (see 5.2).

### 5.1 Flammable substances

**5.1.1** The sample container shall be closed so as to prevent loss of contents or evaporation.

**5.1.2** The samples shall be protected from heat and shall be transported only in a carrier designed to retain the sample in the event of a breakage or a leakage.

**5.1.3** All spillages should be reported and corrected as soon as possible. Spilt flammable liquids should not be allowed to

enter drains unless they are water miscible and can be flushed away with a continuous flow of water.

**5.1.4** Naked lights, smoking and equipment which can produce sparks shall be prohibited.

**5.1.5** Protective goggles and protective clothing should be worn.

**5.1.6** The location of alarm systems and fire fighting equipment should be known.

**5.1.7** Precautions shall be taken to ensure that static electrical charges cannot exist. Rubber-tyred vehicles shall be earthed before operations commence. In fixed installations, sampling points shall be individually earthed. It should be noted that, although these precautions will ensure the absence of a charge on the material being sampled, there is some possibility of the sampler or his clothing carrying a charge. Nylon overalls are often heavily charged in dry weather and cotton is preferred. The sampler should wear conductive footwear.

NOTE — So-called "safety shoes" have, in general, electrically insulating soles.

The flow of fluids can generate static electricity, as can also the mixing of liquids, and sufficient time should be allowed to elapse after movement has stopped and before sampling is undertaken to ensure leakage to earth of the charge generated by movement.

**5.1.8** Sampling from rail tanks should only be undertaken at sidings or goods depots in the absence of all traffic, since sparks, leading to a risk of fire or explosion, could be produced (electric traction, braking, collisions etc.).

## 5.2 Toxic substances

### 5.2.1 Introduction

Poisons may be assimilated by :

- ingestion (see 5.2.2);
- respiration (see 5.2.3);
- absorption (see 5.2.4).

In acute poisoning, i.e. from a single heavy dose, the effects may be associated with immediate discomfort and other symptoms, but in some cases there are delayed effects not appearing for some hours. In all cases, medical attention should be obtained.

Repeated low level doses of some substances are a health hazard because of accumulation of the poison itself in the body or by virtue of accumulated minor physiological changes. Persons exposed to this kind of risk should be periodically examined by a doctor.

Whenever toxic substances are handled or sampled, those persons exposed to the risk shall be made aware of the risk, the symptoms of poisoning and the nature of any delayed effects

and be instructed to seek immediate medical assistance in the event of their feeling unwell in any way. Whenever the substance sampled may have a delayed effect, the sampler should be given a date card stating that he has handled the named substance and bearing the name and telephone number of a medical officer able to advise on the subject.

Whenever personnel are sent away for medical attention, full details of the toxic hazard to which they have been exposed should be sent with them.

### 5.2.2 Substances poisonous if ingested

#### 5.2.2.1 General

Such substances include liquids of low vapour pressure, since poisonous substances of appreciable vapour pressure should be regarded as presenting a major risk via the respiratory system.

#### 5.2.2.2 Additional precautions according to severity of risk

**5.2.2.2.1** Smoking and eating or drinking in the vicinity of the poisonous substance should be prohibited.

**5.2.2.2.2** Adequate washing facilities shall be provided and shall be used by the sampler after securing his sample containers and before leaving the site. Suitable facilities shall also be provided for adequate cleaning of all equipment after the samples are taken.

**5.2.2.2.3** Sampling cocks for liquids should be arranged so that splashing cannot occur and so that any spillage is contained. Facilities shall be provided for isolating the sampling point from the system by a valve near to, but not immediately adjacent to, the sampling point.

**5.2.2.2.4** All sample containers and tools should be clean and fit for use without rinsing with the product. Should rinsing be necessary, or a sampling line require initial purging, suitable marked containers shall be provided for the surplus liquid and specific instructions issued directing the disposal of this surplus.

**5.2.2.2.5** All spillages shall be reported immediately. If necessary, the sampler should wear suitable overalls so that, in the event of them being contaminated, they may be changed. Contaminated clothing should not be sent to a laundry or cleaners until a competent person, aware of the hazards involved, has taken the appropriate steps to remove the contamination.

### 5.2.3 Respiratory poisons

#### 5.2.3.1 General

When respiratory poisons present a health hazard, personnel protection shall be afforded either by providing a supply of fresh air to a suitable face mask or, if not possible, by providing a gas mask fitted with a canister containing the appropriate absorbent.

Absorbent canister protection should be used only if concentrations are low or if the substance is relatively involatile and the absorbent is primarily acting as a filter for dust and droplet particles.

On the other hand, the use of absorbent canisters is prohibited when the nature of the vapour is such that the sampler will be incapable of detecting failure of the mask.

### 5.2.3.2 Additional precautions

**5.2.3.2.1** The appropriate respiratory protection shall be provided and used by all persons engaged in the operation.

**5.2.3.2.2.** Sampling cocks for liquids should be arranged so that splashing cannot occur and spillages are contained. Facilities shall be provided for isolating the sampling point from the system by a valve near to, but not immediately adjacent to, the sampling point.

**5.2.3.2.3** Sample containers shall be tightly closed before leaving the site.

**5.2.3.2.4** All spillages shall be reported immediately. If necessary, the sampler should wear suitable overalls so that, in the event of them being contaminated, they may be changed. Contaminated clothing should not be sent to a laundry or cleaners until a competent person, aware of the hazards involved, has taken the appropriate steps to remove the contamination.

### 5.2.4 Contact poisons

#### 5.2.4.1 General

Contact poisons which enter the system through the skin are often absorbed into subcutaneous tissues without necessarily causing immediate surface damage or sensation.

The vapours of substances in this category should be assumed to be able to enter the body via the skin as readily as the liquid itself and to be respiratory poisons. All these substances are poisonous if ingested.

It is recommended that skin contact with any organic liquids should be avoided and that, regardless of the nature of the chemicals being handled, a sampler should wash his hands free from contamination.

#### 5.2.4.2 Additional precautions

**5.2.4.2.1** The appropriate protective clothing, etc. should be provided and worn. According to the severity of the risk this will be :

- full protective impervious outer clothing, including gloves and boots or overboots and a respirator; or
- impervious apron, gloves, boots and respirator or face mask; or
- face mask and gloves.

Attention is directed to the risk of unsuitable footwear acting as a trap for splashes and of unsuitable gloves absorbing and retaining chemicals.

**5.2.4.2.2** Adequate washing facilities shall be provided, including a warm water shower for preference, or a cold water shower. Before sampling, the sampler should test that the shower is in working order.

**5.2.4.2.3** Contaminated clothing should be immediately removed, and the recommendations given in 5.2.2.2.5 and 5.2.3.2.4 followed.

## 6 Apparatus

### 6.1 Containers

Sample containers are receptacles used for the storage and transport of samples, and shall have a suitable cap or stopper.

The container used shall be impervious to, and resistant to, solvent action by the product handled. It shall be of sufficient strength to withstand normal internal pressures likely to be generated, and sufficiently robust to withstand normal handling.

#### 6.1.1 Glass bottles

**6.1.1.1** Glass bottles shall be provided with a glass or PTFE stopper or a plastics or metal screw-cap fitted with an oil-resistant disc. Corks shall not be used for volatile liquids. If the product is sensitive to light, the sample bottle shall be dark coloured.

**6.1.1.2** Glass bottles and their closures shall be clean and dry. The method of cleaning will depend upon the condition, or previous contents, of the bottle, the nature of the sample, and the tests to be carried out.

#### 6.1.2 Tin cans

These shall be made of suitable tinfoil and should have pressed seams or seams soldered on the exterior surfaces using a flux of resin in a suitable solvent. Cans may be closed by means of screw-caps with oil-resistant discs, which shall be discarded after being used once. Corks shall not be used. Cans and their closures shall be clean and dry. The method of cleaning will depend on the condition, or previous contents, of the can, the nature of the sample and the tests to be carried out. Cans should be inspected before use and rejected if leaks or rust are present.

#### 6.1.3 Plastic bottles

Plastic bottles should not be used.

#### 6.1.4 Closure of sample container

Cork, rubber (chloroprene rubber excluded), cardboard, composition cork or plastics materials (PTFE excluded) should not be allowed to come into direct contact with the sample. If these

materials are used to close sample containers, they should be covered with aluminium or tin foil.

Cans should be fitted with a push-in metal cap as well as a screw cap.

Glass stoppers should be ground to make an airtight fit in the neck of the bottle.

## 6.2 Sampling cage

This shall be a metal holder or cage, suitably constructed to hold the appropriate container. The combined apparatus shall be of such a mass as to sink readily in the material to be sampled, and provision shall be made to fill the container at any desired level (see figures 1 and 2).

The cage shall be connected to the container by a copper cable to prevent the generation of static electricity.

Bottles of special dimensions are required to fit a sampling cage. The use of a sampling cage is generally preferred to that of a weighted sampling can for clean volatile products, since loss of light ends is likely to occur when transferring the sample from a weighted sampling can to another container.

## 6.3 Tube sampler

This is a tube made of glass or metal, if required with suitable fittings to facilitate handling, which can be inserted into a drum or road vehicle to the desired level. It may be used for withdrawing a spot sample from a selected level or a bottom sample to detect the presence of contaminants, or, when designed or handled appropriately and inserted slowly, for taking a representative sample from across a vertical cross-section of the liquid. Typical examples are shown in figures 3 and 4.

## 6.4 Bottom sampler

This is a receptacle, which can be lowered on a spark-proof chain, or cord, to the bottom of a tank, where a valve or closure is opened by contact with the bottom. Typical examples are shown in figure 5.

## 6.5 Device for obtaining a representative sample from vertical tanks

The sampling cages shown in figures 1 and 2 may be used to obtain a representative sample from tanks if the PTFE stopper is not attached to a cord or chain but is fitted with two glass tubes of unequal length (see figure 6). The stopper should be securely fastened to the can.

## 6.6 Pipeline sampling apparatus

This comprises a suitable pipeline probe fitted to extend internally so that the point of sample entry should not be nearer to the pipe wall than one-third of the internal diameter (see figure 7).

Suitable equipment may be provided so that the sample can be taken automatically in a preset or automated manner.

## 6.7 Needle sampling apparatus

A sampling device which allows the taking of samples with almost no flushing consists of a valve with suitable connections, a shield and two syringe needles, one of which is connected to the outlet of the valve for filling the bottle, and the other serving as a vent. The other side of the valve has a connector and probe for mounting permanently in a pipeline or vessel. (See figure 8.)

Sampling is performed as follows.

A glass bottle (of capacity 60 — 300 or 500 ml), having a screw cap and a chloroprene rubber septum, is inserted in the shield, thus punching the septum with the two needles. The valve is opened and the sample is allowed to flow into the bottle. During this procedure the liquid level can be observed through slots in the shield.

Since the liquid volumes of the tubes and the valve of the sampler are very small, flushing can normally be omitted, thus eliminating the problem of disposal of the flushed material, which is of special importance when sampling toxic substances. If, in some cases, it is required to flush the sampling point and sampler, the flushed material can be collected in the bottle and disposed of, the actual sample being collected in a second bottle.

## 7 Number of samples to be taken

The variability of the material both within and between containers, the number of containers sampled, and the precision of the test methods may all contribute to errors in the determination of the properties of the material as shown by the test results. The following recommendations as to the number of samples to be taken give a qualitative assessment of the errors involved.

### 7.1 Sampling to assess uniformity in a container

Spot samples shall be taken from evenly distributed points within the material and each shall be tested. The tests used should be simple and based on easily assessable characteristics such as density, colour, etc.

### 7.2 Sampling to assess the average quality of a consignment

#### 7.2.1 Single container

If the material is uniform, as may have been shown by sampling in accordance with 7.1, a single spot sample may be taken, but otherwise a sufficient number of spot samples should be taken and combined to give a representative sample.

#### 7.2.2 Many containers

The accuracy with which an estimate of the average quality of the material within a number of containers can be made is dependent on

- the number of containers sampled;



- the precision of the test method used;
- the variability of the material between containers.

It is strongly recommended that all the containers in a consignment should be sampled in order to eliminate the majority of these errors but, if this is not practicable and more than one party is interested in the test results, it is recommended that the parties should agree on the number of containers to be sampled and on the number of tests to be carried out on the samples, for example on the basis of the sampling plans given in ISO 2859.

#### 7.2.2.1 Sampling of all the consignment

If all the containers are sampled, this necessarily involves the greatest amount of sampling, and the error in the determination of the average quality will depend on the testing of the samples.

If each of the samples is tested once, the average of the test results will be a measure of the average quality with the lowest error. If a representative sample is prepared and is tested once, the result will be a measure of the average quality, but with a much higher error.

#### 7.2.2.2 Sampling of part of the consignment

The error of the assessment of the average quality will be increased if less than the whole number of containers is sampled, because of variation between the containers. If, however, the work involved in sampling all the containers and testing the samples is considered to be excessive, the following procedure is recommended.

Select a representative number of containers from the consignment according to the table. A random process, preferably one which makes use of a table of random numbers, should be used to choose the containers.

Sample each of the selected containers. An estimate of the average quality may be obtained either by testing each of the samples once and averaging the results or by preparing and testing a representative sample.

**Table — Minimum number of containers to be sampled**

Number of containers in the consignment	Minimum number* to be sampled
1 to 10	All the containers
11 to 49	11
50 to 64	12
65 to 81	13
82 to 101	14
102 to 125	15
126 to 151	16
152 to 181	17
182 to 216	18
217 to 254	19
255 to 296	20
297 to 343	21
344 to 394	22
395 to 450	23
451 to 512	24

\* Based on three times the cube root of the greatest number of containers in the consignment, rounded to the next largest integer.

### 7.3 Sampling to assess the number of defectives in a consignment

It is recommended that every container in the consignment should be sampled and tested. If, however, some error can be tolerated, the parties concerned should agree on the procedure to be adopted, for example on the basis of the sampling plans given in ISO 2859.

## 8 Sampling of mobile liquids

### 8.1 General

At low ambient temperatures some mobile liquids, for example pure benzene, deposit crystals. If the presence of crystals is suspected, an examination should be made and, if crystals are found, the material should be sampled as described in clause 9.

A final sample should only be withdrawn from a bulk sample after thorough mixing, preferably by shaking.

### 8.2 Sampling from drums and casks

#### 8.2.1 Spot sample

The drum or cask, which should be disturbed as little as possible, should be sampled by means of a closable sampling tube (see figure 4). The tube should be closed, lowered to the required depth in the liquid and opened for a short period. The tube should then be withdrawn, any adhering liquid allowed to drain off, and the contents discharged into a sample container.

NOTE — The sampler should realize that, when a sampling tube is used, different amounts of sample will be taken according to the depth of immersion in the liquid.

#### 8.2.2 Representative sample

The contents of the drum or cask should first be mixed by means of a hand-mixer, or drum mixer, or by rocking the closed drum in a see-saw fashion on a wooden block. Mixing by rolling is ineffective and should not be used. Care should be taken in opening a drum that has been rocked. The sample should then be withdrawn from the mixed contents by means of an open sampling tube (see figure 3) chosen to suit the viscosity of the liquid to be sampled. Without touching the sides of the bung-hole, the tube should be lowered so that the liquid level in the tube does not fall below that of the outside liquid. The tube should be closed, withdrawn from the container, and any liquid adhering to the outside of the tube allowed to drain off; the tube should not be wiped. The tube should then be opened and the contents allowed to drain into a sample container. Repeat the operation if necessary; a larger sample should not be obtained by means of a pumping action.

### 8.3 Sampling from tanks having a uniform horizontal cross-section throughout their depth, including ships tanks

#### 8.3.1 Spot sample

For a shallow tank, use the closable sampling tube as described in 8.2.1. For deep tanks use the sampling cage (6.2). This is

essential in hot weather or when the material is volatile. The cage should be tightly closed, lowered to the required depth and then opened by sharply jerking the cord or chain. The can or cage should be lifted out when air bubbles cease to rise.

When the apparatus is raised, some contamination of the contents by the upper layers takes place and it is therefore recommended that, when the liquid on the outside has drained off, about a quarter of the contents is rapidly poured off. If the weighted sampling can has been used, a part or the whole of the remainder of the liquid in the can should be transferred to a sample container. If the sampling cage has been used, the bottle should be tightly closed and removed from the cage. If more than one spot sample is required, the order of taking the samples should be from the top downwards so that each sample is obtained from undisturbed material.

### 8.3.2 Representative sample

Take one sample from the thoroughly mixed contents of a tank (see clause 4). For shallow tanks use the open sampling tube as described in 8.2.2. For deep tanks use the sampling cage as described in 8.3.1. If the contents of the tank have not been mixed, a representative sample may be obtained from a shallow tank by use of the open sampling tube as described in 8.2.2, except that the tube should touch the bottom of the tank before it is closed. For deep tanks, a number of spot samples should be taken, using the sampling cage as described above. Spot samples should be taken every 300 mm throughout the depth of the liquid to be discharged and combined to give a representative sample. The number of spot samples taken should be increased if the presence of layers is suspected.

Tanks, the contents of which have been homogenized by recycling through a pump, may be sampled at the discharge of the pump.

A representative sample from deep tanks can also be taken by using a sample container with a PTFE stopper provided with two glass tubes (see figure 6 and 6.5). The container in a sampling cage is lowered to the bottom of the tank and withdrawn again in such a way that the can is not filled completely at the end of the operation.

### 8.3.3 Tank-side sampling

Tank-side sampling is preferable, if suitably designed taps or valved connections are fitted to the side of a tank, and extending a minimum of 150 mm into the tank. If layering is likely to occur, three or more such connections fitted at different levels may be necessary to prepare a representative sample of the tank contents, but one such connection may suffice if the contents are mixed before sampling.

Before a sample is taken, flush the tap or valved connection with the product to be sampled, after which draw off a sample into a container or receiver.

**CAUTION** — Taps shall be opened with care when sampling under pressure. No attempt shall be made to clear a blocked connection by rodding through an opened valve.

When the contents of a tank fail to reach the upper or middle sample connections on a tank equipped with three connec-

tions, it is suggested that the sample for the tank be obtained as follows.

If the level of the contents is nearer the upper sample connection than the middle, two-thirds of the sample shall be taken from the middle connection and one-third from the lower. If the level is nearer the middle connection than the upper, one-half shall be taken from the middle and one-half from the lower. If the level of the contents is below the middle sample connection, all of the samples shall be taken from the lower connection.

## 8.4 Sampling from horizontal cylindrical tanks

Use the methods described in 8.3 to obtain spot samples and, if the contents have been mixed, a representative sample. If the tank is full and the contents have not been mixed, spot samples of equal volume should be drawn at depths of  $d/4$ ,  $d/2$ , and  $3d/4$ , where  $d$  is the diameter of the tank. If the tank is not full or if it has hemispherical ends, the sampler should adjust the depths to ensure that each of the three withdrawals represents an equal volume of liquid in the tank.

## 8.5 Sampling from pipelines

### 8.5.1 General

The methods given below are the best available but may fail to give a correct sample if the liquid is contaminated with material of very different density, for example water.

The sampling line should be as short as possible to reduce the volume needed to purge the line.

### 8.5.2 Large flows

The sample should be obtained from a pipeline sampler installed in the pipeline as described in 6.6. Before a sample is taken, the sampling line should be cleared by opening the stopcock and running a small quantity of the liquid to waste.

The mean velocity, at the orifice, of sample flowing through the probe should be adjusted so that it is approximately equal to 1,2 times the mean velocity of the liquid in the pipeline during the period in which the sample is being taken.

#### 8.5.2.1 Spot sample

The stopcock should be opened and the required quantity run off.

#### 8.5.2.2 Representative sample

The stopcock should be opened and the sample allowed to flow into a ladle or can through the transfer of the liquid through the pipeline.

### 8.5.3 Small flows

Small flows should be sampled from the discharge end of the pipeline by a ladle or can, held in the exit stream for a short period. The ladle or can should be of sufficient size to contain all of the exit stream to be collected in this period.

### 8.5.3.1 Spot sample

A spot sample is one such collection.

### 8.5.3.2 Representative sample

Combine a number of such spots samples taken at regular intervals during the whole time of the transfer of the liquid.

### 8.5.3.3 Automatic pipeline sampling

See ISO 3171.

## 8.6 Sampling from road or rail tanks

If it can be assumed that the contents are well mixed, a representative sample may be obtained by the methods described in 8.3, provided that the tank is fitted with a filling opening in a manhole.

If the contents are not mixed, or if the tank is fitted with a fill-pipe, a representative sample may be obtained on unloading by one of the methods described in 8.5.

In tanks having more than one compartment, each compartment should be sampled separately.

## 9 Sampling of partly solidified liquids and liquefiable solids

**WARNING — Attention is drawn to the dangers involved in heating solidified liquids, which may be toxic, flammable or explosive.**

### 9.1 General

Products in this category are those that, at the prevailing temperature, have deposited crystals or have solidified.

These products should be sampled as mobile liquids, which can only be obtained by heating and mixing the material in the container. If this is impracticable, the material should be sampled on discharge by one of the methods described in clause 8.

Care is necessary in sampling these materials if they have been liquefied. Cold sampling apparatus, particularly when made of glass, should not be used. It is advisable, if the sampling apparatus has to be lowered into the liquefied material, that this operation should be carried out slowly. The apparatus should then be allowed to remain in the liquid for a few minutes, so that it may reach the temperature of the liquid.

A final sample should be withdrawn from a bulk sample after it has been heated (to liquefy any solid) and mixed thoroughly.

### 9.2 Sampling from drums and other containers

It is preferable to leave the drum in a heated room until the contents have liquefied. Alternatively, the drum could be heated in an open tank on a grid, below which is fitted a closed steam

coil. In either case, it is necessary for the drum to be in a sound condition and for the bung to be at its highest position and loosened. Immediately after the contents of the drum become fluid, the bung should be tightened and the drum removed from the source of heat. The contents should then be sampled as described in clause 8.

## 10 Final samples

Samples shall be protected from light, moisture and dust, and from excessive heat or cold. Protection against moisture and dust may be obtained by covering the stopper and top of the container with a cap of paper, plastics material or metal.

### 10.1 Labelling of sample container

All sample containers shall be labelled as soon as the samples are taken. The labels shall bear all the necessary information to enable the samples to be identified without dispute. The label and marking ink used shall be capable of withstanding moisture and solvents. The label shall not be attached to the stopper, but to the neck or body of the container.

It is recommended that the following particulars should be given on the label :

- a) a description of the material;
- b) the size and particulars of consignment (tank-wagon, tank, ship, barrel, drum);
- c) the designation and reference number of the sample;
- d) the consignor;
- e) the place of sampling;
- f) the date of sampling;
- g) the name of the sampler.

### 10.2 Sealing

If a sample has to be stored for reference purposes, the container should be sealed, for example by a metal thread over the closure and around the neck of the container, which is plumb-ed, and coded.

### 10.3 Packaging of the sample

If a sample has to be forwarded, it should be protected by putting it in a plastics or wooden case, if possible filled with absorbent material. The case should bear the appropriate danger signs prescribed by the UNO (UN class 3 for flammable materials, UN class B for poisonous materials).

## 11 Delivery note

Samples shall be accompanied by a delivery note repeating the details given on the label and, if necessary, by a report giving all the details of sampling.

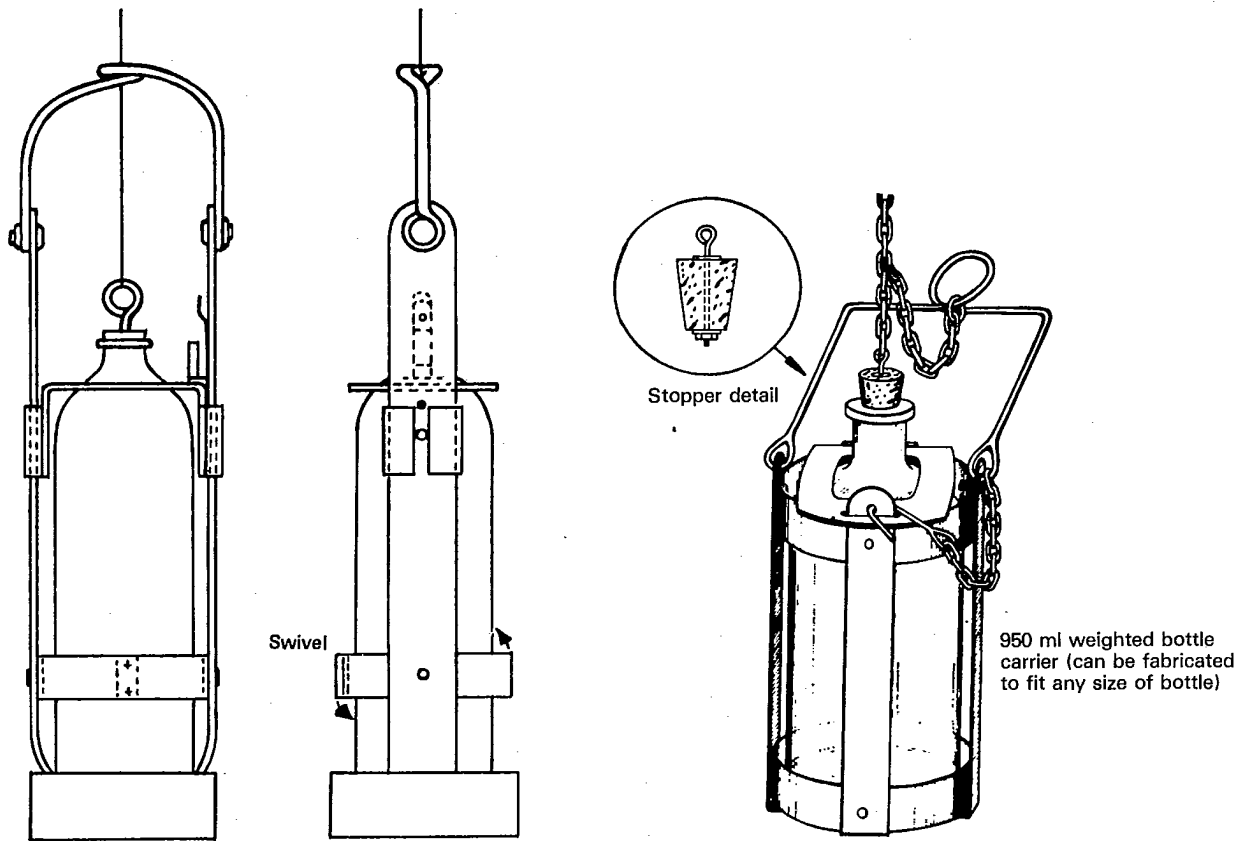

Figure 1 — Examples of sample cages

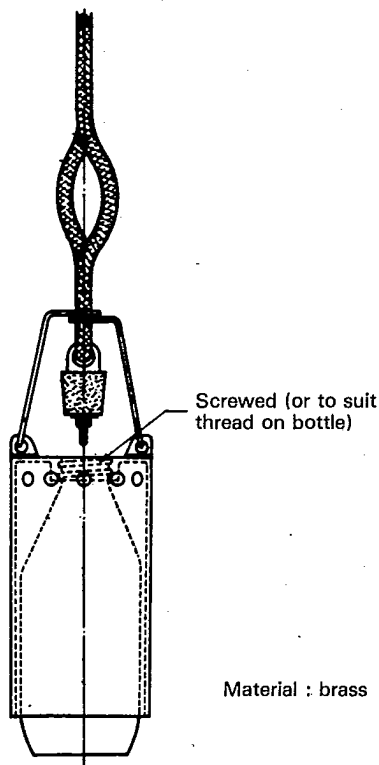

Figure 2 — Example of sampling cage for use with screw-top glass 600 ml sample bottle

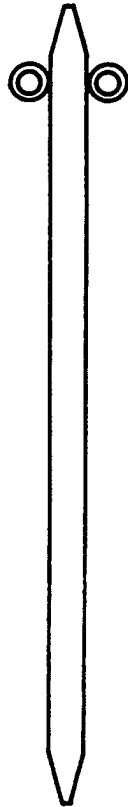

Figure 3 — Sampling tube with single tube

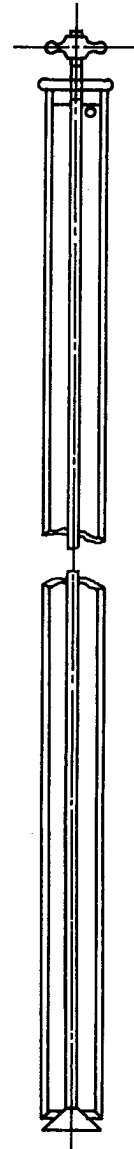
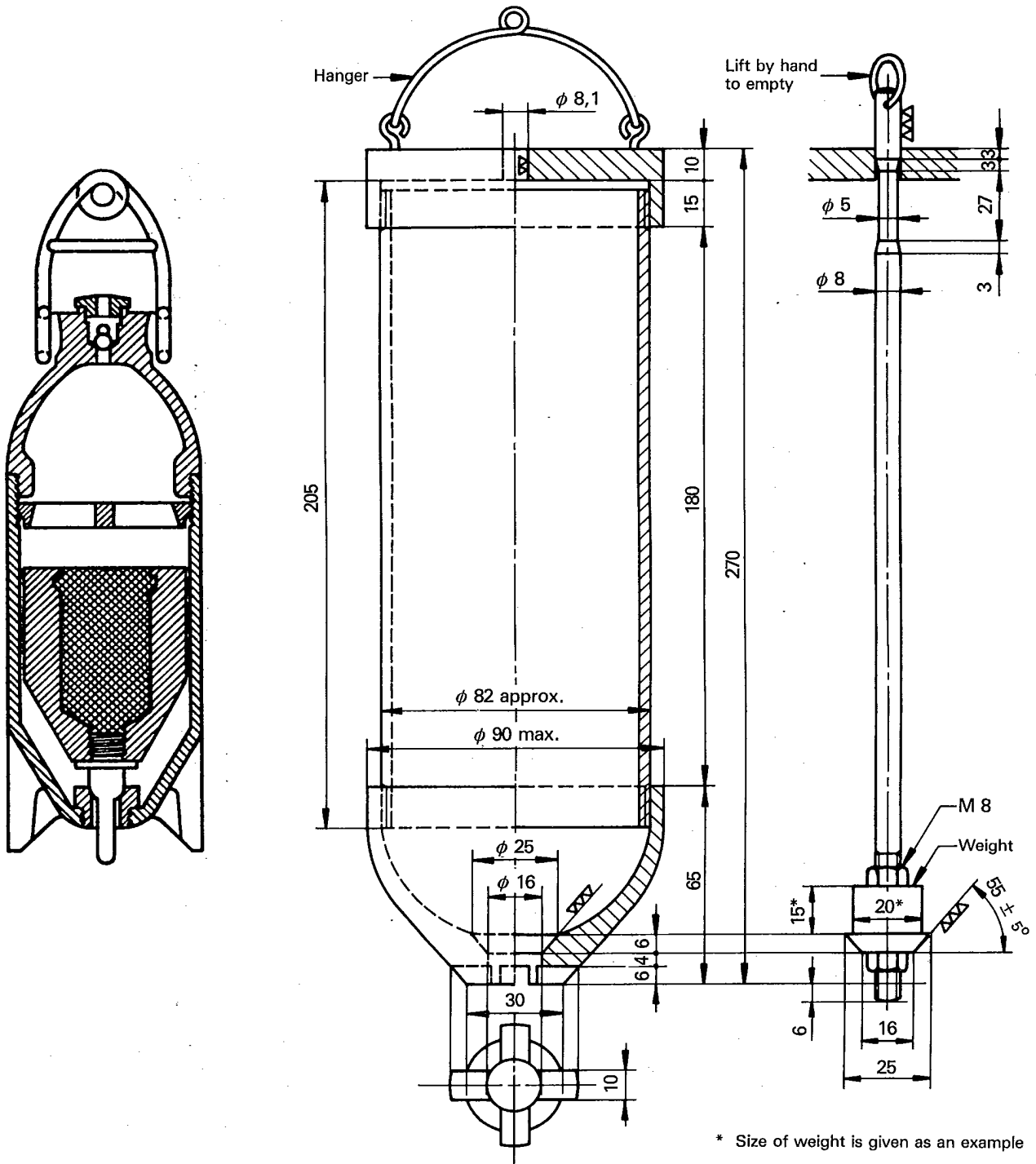

Figure 4 — Valve sampling tube

Dimensions in millimetres



\* Size of weight is given as an example

NOTE — The sampler shall be heavy enough to sink in a liquid of density 1,000 kg/l.

Figure 5 — Examples of bottom samplers

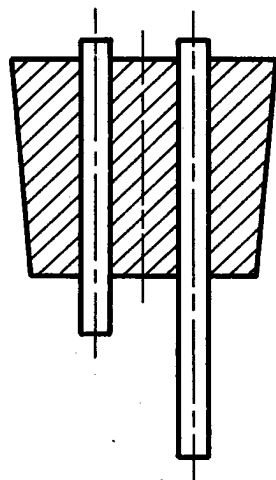

Figure 6 — Stopper for representative sampling

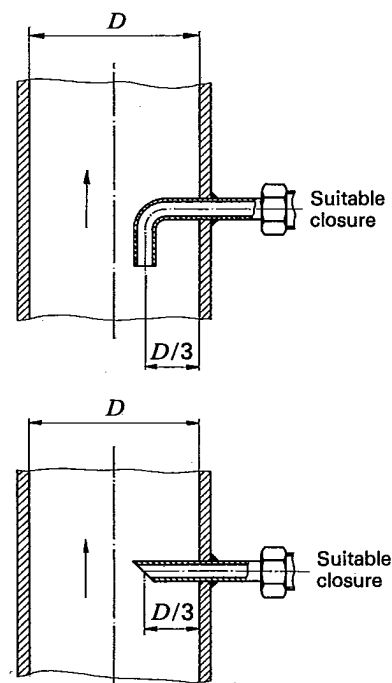

Figure 7 — Typical pipeline sampling apparatus

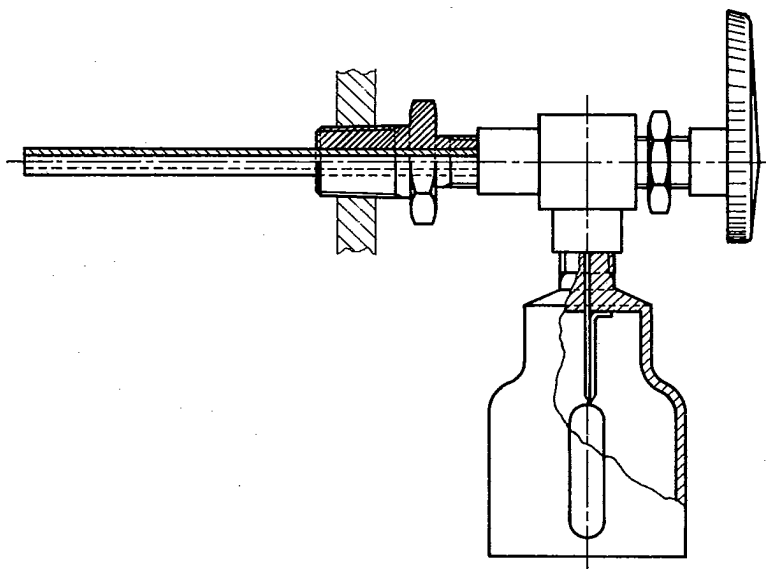

Figure 8 — Needle sampler