**Monolithic (unshaped) refractory
materials —**

**Part 3:
Characterization as received**

Produits réfractaires monolithiques (non façonnés) —

Partie 3: Caractérisation à l'état de réception



Reference number
ISO 1927-3:2012(E)

© ISO 2012



COPYRIGHT PROTECTED DOCUMENT

© ISO 2012

All rights reserved. Unless otherwise specified, no part of this publication may be reproduced or utilized in any form or by any means, electronic or mechanical, including photocopying and microfilm, without permission in writing from either ISO at the address below or ISO's member body in the country of the requester.

ISO copyright office
Case postale 56 • CH-1211 Geneva 20
Tel. + 41 22 749 01 11
Fax + 41 22 749 09 47
E-mail copyright@iso.org
Web www.iso.org

Published in Switzerland

Contents

Page

Foreword	iv
1 Scope	1
2 Normative references	1
3 Principle	2
4 Sampling	3
5 Determination of chemical composition	3
5.1 Preparation of test sample	3
5.2 Alumina-silica products	3
5.3 Basic products	3
5.4 Special products	3
5.5 Carbon-containing products	3
6 Determination of grain-size distribution	3
6.1 Principle	3
6.2 Apparatus	3
6.3 Quantity of sample	4
6.4 Preparation of test samples	4
6.5 Procedure	4
6.6 Expression of results	6
7 Determination of moisture content	6
7.1 Preparation of test sample	6
7.2 Quantity of sample	6
7.3 Procedure	6
7.4 Calculation	7
8 Determination of workability index	7
8.1 General	7
8.2 Apparatus	7
8.3 Preparation of test pieces	9
8.4 Procedure and calculation	10
9 Test report	10
Annex A (informative) Summary of tests	11

Foreword

ISO (the International Organization for Standardization) is a worldwide federation of national standards bodies (ISO member bodies). The work of preparing International Standards is normally carried out through ISO technical committees. Each member body interested in a subject for which a technical committee has been established has the right to be represented on that committee. International organizations, governmental and non-governmental, in liaison with ISO, also take part in the work. ISO collaborates closely with the International Electrotechnical Commission (IEC) on all matters of electrotechnical standardization.

International Standards are drafted in accordance with the rules given in the ISO/IEC Directives, Part 2.

The main task of technical committees is to prepare International Standards. Draft International Standards adopted by the technical committees are circulated to the member bodies for voting. Publication as an International Standard requires approval by at least 75 % of the member bodies casting a vote.

Attention is drawn to the possibility that some of the elements of this document may be the subject of patent rights. ISO shall not be held responsible for identifying any or all such patent rights.

ISO 1927-3 was prepared by Technical Committee ISO/TC 33, *Refractories*.

ISO 1927 consists of the following parts, under the general title *Monolithic (unshaped) refractory products*:

- *Part 1: Introduction and classification*
- *Part 2: Sampling for testing*
- *Part 3: Characterization as received*
- *Part 4: Determination of consistency of castables*
- *Part 5: Preparation and treatment of test pieces*
- *Part 6: Measurement of physical properties*
- *Part 7: Tests on pre-formed shapes*
- *Part 8: Determination of complementary properties*

Monolithic (unshaped) refractory materials —

Part 3: Characterization as received

1 Scope

This part of ISO 1927 specifies the methods for the characterization of monolithic (unshaped) refractory materials as received and for checking the homogeneity of a delivery of a product. It is applicable to castables (dense and insulating), gunning materials tap hole clay, injection mixes, dry vibrating mixes, and ramming materials, as defined in ISO 1927-1.

NOTE A check list of appropriate tests is given in Annex A.

2 Normative references

The following referenced documents are indispensable for the application of this document. For dated references, only the edition cited applies. For undated references, the latest edition of the referenced document (including any amendments) applies.

ISO 565, *Test sieves — Metal wire cloth, perforated metal plate and electroformed sheet — Nominal sizes of openings*

ISO 1927-1, *Monolithic (unshaped) refractory products — Part 1: Introduction and classification*

ISO 1927-2, *Unshaped refractory materials — Part 2: Sampling for testing*

ISO 10058-1, *Chemical analysis of magnesite and dolomite refractory products (alternative to the X-ray fluorescence method) — Part 1: Apparatus, reagents, dissolution and determination of gravimetric silica*

ISO 10058-2, *Chemical analysis of magnesite and dolomite refractory products (alternative to the X-ray fluorescence method) — Part 2: Wet chemical analysis*

ISO 10058-3, *Chemical analysis of magnesite and dolomite refractory products (alternative to the X-ray fluorescence method) — Part 3: Flame atomic absorption spectrophotometry (FAAS) and inductively coupled plasma atomic emission spectrometry (ICP-AES)*

ISO 12677, *Chemical analysis of refractory products by XRF — Fused cast bead method*

ISO 14719, *Chemical analysis of refractory material, glass and glazes — Determination of iron 2+ and iron 3+ by the spectral photometric method with 1-10 phenanthroline*

ISO 14720-1, *Testing of ceramic raw and basic materials — Determination of sulfur in powders and granules of non-oxidic ceramic raw and basic materials — Part 1: Infrared measurement methods*

ISO 14720-2, *Testing of ceramic raw and basic materials — Determination of sulfur in powders and granules of non-oxidic ceramic raw and basic materials — Part 2: Inductively coupled plasma atomic emission spectrometry (ICP/AES) or ion chromatography after burning in an oxygen flow*

EN 15979, *Testing of ceramic raw and basic materials — Direct determination of mass fractions of impurities in powders and granules of silicon carbide by OES by DC arc excitation*

EN 15991, *Testing of ceramic and basic materials — Direct determination of mass fractions of impurities in powders and granules of silicon carbide by inductively coupled plasma optical emission spectrometry (ICP OES) with electrothermal vaporisation (ETV)*

ISO 20565-1, *Chemical analysis of chrome-bearing refractory products and chrome-bearing raw materials (alternative to the X-ray fluorescence method) — Part 1: Apparatus, reagents, dissolution and determination of gravimetric silica*

ISO 20565-2, *Chemical analysis of chrome-bearing refractory products and chrome-bearing raw materials (alternative to the X-ray fluorescence method) — Part 2: Wet chemical analysis*

ISO 20565-3, *Chemical analysis of chrome-bearing refractory products and chrome-bearing raw materials (alternative to the X-ray fluorescence method) — Part 3: Flame atomic absorption spectrometry (FAAS) and inductively coupled plasma atomic emission spectrometry (ICP-AES)*

ISO 21068-1, *Chemical analysis of silicon-carbide-containing raw materials and refractory products — Part 1: General information and sample preparation*

ISO 21068-2, *Chemical analysis of silicon-carbide-containing raw materials and refractory products — Part 2: Determination of loss on ignition, total carbon, free carbon and silicon carbide, total and free silica and total and free silicon*

ISO 21068-3, *Chemical analysis of silicon-carbide-containing raw materials and refractory products — Part 3: Determination of nitrogen, oxygen and metallic and oxidic constituents*

ISO 21078-1, *Determination of boron (III) oxide in refractory products — Part 1: Determination of total boron (III) oxide in oxidic materials for ceramics, glass and glazes*

ISO 21078-2, *Determination of boron (III) oxide in refractory products — Part 2: Acid extraction method for the determination of boron (III) oxide in binder components*

ISO 21079-1, *Chemical analysis of refractories containing alumina, zirconia and silica — Refractories containing 5 % to 45 % of ZrO₂ (alternative to the X-ray fluorescence method) — Part 1: Apparatus, reagents and dissolution*

ISO 21079-2, *Chemical analysis of refractories containing alumina, zirconia, and silica — Refractories containing 5 % to 45 % of ZrO₂ (alternative to the X-ray fluorescence method) — Part 2: Wet chemical analysis*

ISO 21079-3, *Chemical analysis of refractories containing alumina, zirconia, and silica — Refractories containing 5 % to 45 % of ZrO₂ (alternative to the X-ray fluorescence method) — Part 3: Flame atomic absorption spectrophotometry (FAAS) and inductively coupled plasma emission spectrometry (ICP-AES)*

ISO 21587-1, *Chemical analysis of aluminosilicate refractory products (alternative to the X-ray fluorescence method) — Part 1: Apparatus, reagents, dissolution and gravimetric silica*

ISO 21587-2, *Chemical analysis of aluminosilicate refractory products (alternative to the X-ray fluorescence method) — Part 2: Wet chemical analysis*

ISO 21587-3, *Chemical analysis of aluminosilicate refractory products (alternative to the X-ray fluorescence method) — Part 3: Inductively coupled plasma and atomic absorption spectrometry methods*

ISO 26845, *Chemical analysis of refractories — General requirements for wet chemical analysis, atomic absorption spectrometry (AAS) and inductively coupled plasma atomic emission spectrometry (ICP-AES) methods*

3 Principle

Monolithic (unshaped) refractory products are characterized by making the following determinations:

- a) chemical composition;
- b) grain-size distribution by means of sieve analysis;
- c) moisture content of ramming materials;
- d) workability index of wet ramming materials.

It is not necessary to carry out all of these determinations to characterize a material.

4 Sampling

Take samples in accordance with the guidance given in ISO 1927-2 and prepare the quantities required by each individual determination.

5 Determination of chemical composition

5.1 Preparation of test sample

For ramming materials supplied wet, dry the samples (see Clause 4) in accordance with 6.5.1. For all samples, reduce the amount by coning and quartering and grind to the particle size required for chemical analysis.

NOTE The methods of chemical analysis used include the determination of loss on ignition.

5.2 Alumina-silica products

Determine the chemical composition in accordance with ISO 12677, ISO 14719, ISO 21078, ISO 26845 or ISO 21587, as appropriate.

Report the method used.

5.3 Basic products

Determine the chemical composition in accordance with ISO 12677, EN 15991, ISO 14720, ISO 28645 or ISO 10058 as appropriate.

Report the method used.

5.4 Special products

Determine the chemical composition in accordance with ISO 12677, EN 15979, EN 15991, ISO 21068, ISO 14720, ISO 21079, ISO 26845 or ISO 20565 as appropriate.

The methods used shall be indicated in the test report.

5.5 Carbon-containing products

Carry out the elemental analysis of the oxide constituents on the calcined product, in accordance with either 5.2 or 5.3.

Any other non-oxide constituents should be analysed in accordance with in 5.4.

6 Determination of grain-size distribution

6.1 Principle

The grain-size distribution is measured by determining the amount of material retained on the range of sieves and is expressed as a percentage of the total initial dry mass of material.

6.2 Apparatus

6.2.1 Balance, capable of reading to the nearest 0,1 g.

6.2.2 Sieves, conforming to the requirements of ISO 565 and having a diameter of 200 mm or greater.

6.2.3 Sieving apparatus. The working characteristics of the apparatus shall be indicated (e.g. vibration characteristics, amplitude and frequency).

6.2.4 Drying oven, preferably with an exhaust.

6.2.5 Soxhlet apparatus.

6.2.6 Electric hotplate or heating mantle.

6.3 Quantity of sample

Take the following quantities of sample, from that obtained in Clause 4, for a single test, selecting in accordance with the maximum size of grains:

- a) maximum grain size up to 2 mm: 100 g;
- b) maximum grain size up to 6 mm: 250 g;
- c) maximum grain size up to 10 mm: 500 g;
- d) maximum grain size above 10 mm: 1 000 g

expressed in terms of dry material.

These quantities are related to dense materials. When testing insulating materials, the sample quantity may be reduced according to the bulk density without any reduction of the test accuracy. The reduced quantity shall be given in the test report.

6.4 Preparation of test samples

Reduce the sample in accordance with ISO 1927-2, taking care to avoid any fragmentation, to produce the required number of test portions, each of which complies with the minimum minimum quantity of sample given in 6.3.

In the case of ramming materials containing oil or tar, submit the sample to the following preliminary treatment, taking sufficient sample to enable reduction to be carried out after the pre-treatment.

Warm the sample in an evaporating dish and break it down with a spatula, taking care not to crush any of the grains. Place the sample in filter thimbles in one or more Soxhlets. Carry out the extraction with boiling toluene; an electric hotplate or a heating mantle being used as a means of heating. The extraction is complete when the toluene siphoned over is colourless.

6.5 Procedure

6.5.1 Drying and measurement of dry sample mass

Samples of castables, gunning materials, dry mixes and ramming materials, following the removal of oil or tar shall be dried at (110 ± 5) °C to constant mass and cooled to ambient temperature.

Weigh the test sample to the nearest 0,1 g and record the mass as m_1 .

Ramming materials containing fine particles and non-organic liquid are not dried before sieving in order to avoid hardening and difficult dispersion (see 6.5.2.3). A separate sample is used to determine the moisture

content of the material using the method given in Clause 7. Calculate the mass of dry material contained in the test sample for sieving, m_1 , using the equation:

$$m_1 = m_0 - \left(\frac{m_c \cdot m_0}{100} \right)$$

where

m_0 is the mass of the test sample as received i.e. prior to any drying, in grams;

m_1 is the mass of the test sample, in grams;

m_c is the moisture content determined using a separate sample, in percent.

6.5.2 Sieving

6.5.2.1 General

Two methods may be used for sieving using sieves conforming to the requirements of ISO 565 and taken from the following range:

- 0,063 mm
- 0,125 mm
- 0,25 mm
- 0,5 mm
- 1,0 mm
- 2,0 mm
- 4,0 mm
- 8,0 mm
- 16,0 mm

6.5.2.2 Direct dry sieving

This is a quick method and should be used only for materials containing few particles of size less than 10 μm . The test sample, prepared and weighed in accordance with 6.5.1 is sieved using the selected sieves, a receiver and an appropriate efficient sieve shaker. The total time of sieving shall not exceed 15 min. Weigh the material remaining on each sieve and record the masses as m_n where n is the mesh size of the sieve.

6.5.2.3 Dry sieving after washing

This method may be used for all materials and is the preferred method for quality control and referee purposes; it is the essential method for samples of wet ramming materials containing fine particles and non-organic liquid which have not been dried prior to sieving (see 6.5.1).

The sample, prepared in accordance with 6.5.1, shall be washed on a fine sieve, of aperture 0,063 mm or 0,125 mm. Use a shower for diluting and washing the mass. Hand sieve the material under the water flow, using a to and fro movement. Stop washing as soon as the water passing through the sieve does not carry fine particles and becomes translucent.

Remove the retained material from the sieve, dry at $(110 \pm 5)^\circ\text{C}$ to constant mass, cool to ambient temperature and weigh to of the nearest 0,1 g. Record the mass as m_2 .

Check that the dried material is free of agglomeration and dry sieve it as described in 6.5.2.2.

NOTE If the materials contain cement, it is advisable to wash the sieves used for wet sieving with citric acid solution.

6.6 Expression of results

For dry sieving, calculate the percentage of the sample, r_n , retained on the sieve of mesh size n using the equation:

$$r_n = \frac{m_n}{m_1} \times 100$$

where

m_n is the mass retained on sieve of mesh size n , in grams;

m_1 is the mass of the sample.

For dry sieving after washing, calculate the percentage of the sample passing through the washing sieve, r_w , using the equation:

$$r_w = \left[\frac{m_1 - m_2}{m_1} \right] \times 100$$

where

m_1 is the mass of the sample dried at 110 °C, in grams;

m_2 is the mass of the material retained on the finest sieve, after washing and drying, in grams;

and calculate the percentage of the sample retained on any given mesh using the equation:

$$r_n = \frac{m_n}{m_1} \times 100$$

where m_n is the mass retained on sieve of mesh n , in grams.

7 Determination of moisture content

7.1 Preparation of test sample

A bulk sample shall be constituted by taking at least four increments from several packed units at different points, which are then mixed and reduced by quartering (see ISO 1927-2). Plastics shall be broken into pieces of less than 25 mm before mixing. To avoid moisture loss, breaking and mixing shall be carried out quickly by hand in a room at ambient temperature.

7.2 Quantity of sample

The mass of test sample for each determination shall not be less than 200 g and shall be taken from the mixed material.

7.3 Procedure

Weigh the test sample to the nearest 0,1 g and record the mass as m_0 . Place it in a drying oven at (110 ± 5) °C, dry to constant mass and re-weigh, and record the mass as m_1 .

If the test sample contains a hardening agent such as sodium silicate, a glass rod should be weighed together with the sample and used during drying to break the sample into small pellets.

Record the constant mass attained, to $\pm 0,1$ g.

7.4 Calculation

Calculate the moisture content of the sample as the loss in mass, w , as a percentage of the original mass using the following equation:

$$w = \left(\frac{m_0 - m_1}{m_0} \right) \times 100$$

where

m_0 is the mass of the test sample obtained from 7.2, in grams;

m_1 is the constant mass obtained from 7.3, in grams.

8 Determination of workability index

8.1 General

This determination is applied to wet ramming materials and to other materials such as taphole clays. The workability index depends on the moisture content and also the temperature for the taphole clays and gives additional information on the ramming behaviour of these products and fitness for use .

Because variation of the workability index of plastic materials, as a function of time, is frequently observed during the first weeks of their production, the date of the test in relation to the date of production should be noted and the temperature of the sample noted for taphole clays.

8.2 Apparatus

8.2.1 Sandrammer, consisting essentially of a cylindrical steel mould, of 50 mm inside diameter, 140 mm in length, supported in a vertical position on the same axis as a shaft to which shall be fastened a plunger that fits inside the mould. A 6,67 kg \pm 50 g cylindrical weight slides on the same shaft and is arranged to fall a distance of 50 mm before engaging a collar fastened to the shaft. As shown in Figure 1, the weight may be raised by a manually rotated cam.

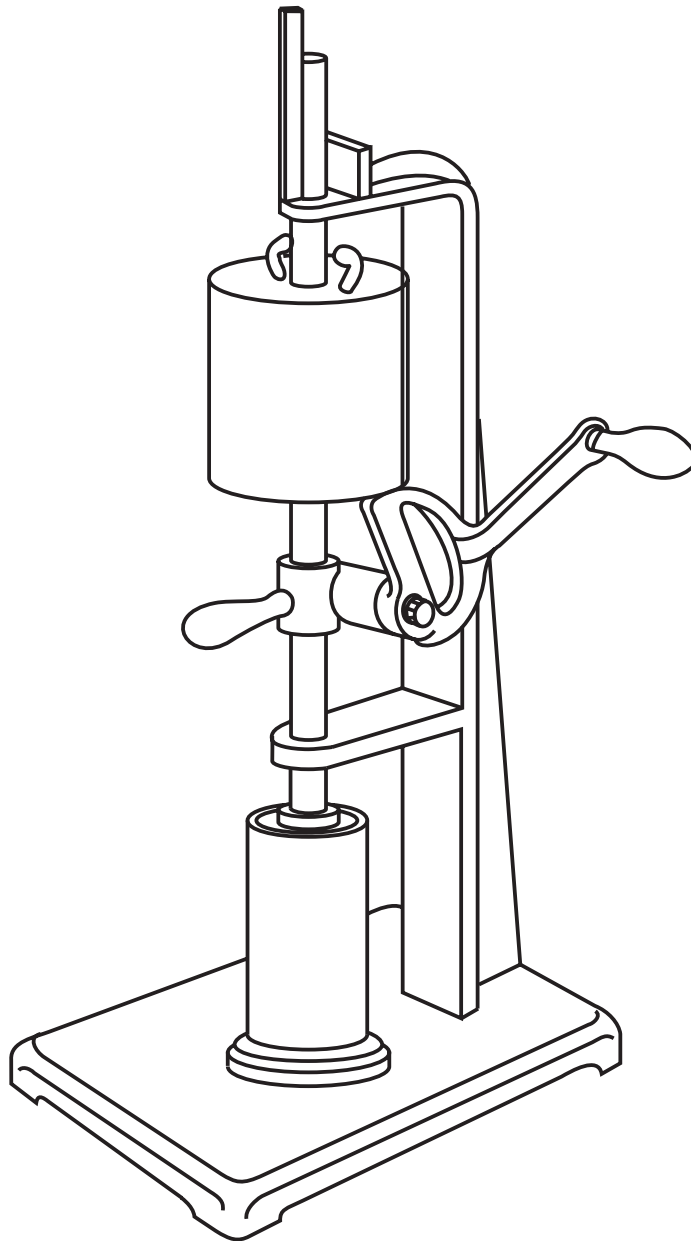

NOTE Each turn of the handle causes the weight to be raised and then dropped on the collar attached to the plunger shaft.

Figure 1 — Apparatus for workability test

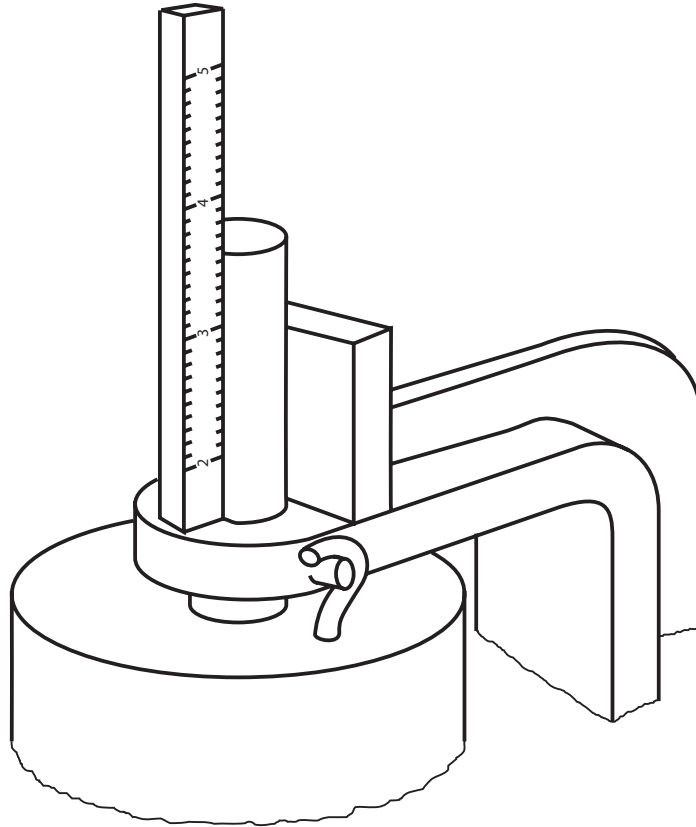

NOTE Steel rule graduated in 0,5 mm increments.

Figure 2 — Modification of apparatus for workability test

The sandrammer shall be modified by making provision to support the weight, thereby removing the load from the vertical shaft as long as the modifications maintain the weight tolerance stated above.

NOTE 1 A convenient method of supporting the weight is by installing two hooks in the top of the weight which engage pins placed in the upper part of the framework (see Figures 1 and 2).

The collar, which is normally attached to the shaft above the weight, shall be removed so that the weight can be raised to the required height.

The sandrammer shall be firmly mounted by bolting it to a substantial, dense base (e.g. a concrete block). Variable results may be obtained unless a suitable mounting is used.

An auxiliary plunger, consisting of a metal plate attached to a handle is required to extrude compacted test pieces from the mould.

NOTE 2 The apparatus described is capable of measuring workabilities up to about 32 %. For products of higher workability, a steel spacer block of approximately 25 mm can be installed under the test piece to increase the range to 60 %.

8.2.2 Callipers or steel rule, attached to the upper part of the sandrammer so that the position of the machined end of the vertical shaft can be read (Figures 1 and 2). The measuring device shall be capable of measuring the height of the test piece to the nearest 0,5 mm

8.3 Preparation of test pieces

Prepare a bulk sample in accordance with 7.2 and either store it in an airtight container until required, or use it immediately. The object is to prepare a consolidated test piece of 50 mm height. Accordingly, depending upon the compacted bulk density, place approximately 200 g to 300 g of the bulk sample in the lightly oiled mould and the impact device gently lowered into contact with the material while keeping the mould in firm contact

with the base of the apparatus. Subject the material to 10 impacts from the plunger. Remove the mould from the base, then turn it upside down. Replace the mould on the base and, by means of the impact device, gently press down the test piece in the mould until it comes into contact with the base of the apparatus and then subject it to a further 10 impacts. Remove the mould from the apparatus and extrude the test piece using the auxiliary plunger, taking care that the upper and lower surfaces of the test piece remain plane and parallel.

The height of the test piece should now be $50 \text{ mm} \pm 2 \text{ mm}$. If this is not the case, repeat the procedure using an appropriate bulk sample mass.

8.4 Procedure and calculation

Measure the height of the test piece to the nearest 0,5 mm using callipers or the steel rule. Record the height as h_1 . Ensure that the test piece is located centrally below the impact device. Gently lower the plunger on the test piece and apply three impacts. Re-measure the height of the test pieces. Record the height as h_2 , and calculate the workability index, W_1 , from the following equation:

$$W_1 = \frac{100(h_1 - h_2)}{h_1}$$

Carry out three tests and report the mean value. Note the nature of any crack appearing in the piece on completion of the test.

9 Test report

The test report shall include the following information:

- a) all information necessary for identification of the sample tested, including the date of production of the batch and the designation of the material tested, in accordance with ISO 1927-1;
- b) a reference to this International Standard, ISO 1927-3:2012;
- c) the method used;
- d) the results of the test, including as appropriate:
 - 1) chemical composition and method used for analysis;
 - 2) results of grain-size distribution, including details about the method used:
 - quantity of test sample;
 - direct dry sieving or dry sieving after washing;
 - the residues on the sieves listed in 6.5;
 - 3) the moisture content of wet ramming materials and taphole mixes, as expressed in 7.4;
 - 4) the workability index of wet ramming materials and taphole mixes (see Clause 8) and the nature of any crack which appeared on completion of the test;
- e) any deviations from the procedure specified;
- f) any unusual features (anomalies) observed during the test;
- g) the name of the test laboratory;
- h) the date of the test.

Annex A (informative)

Summary of tests

Table A.1 shows the tests which can be performed, depending on the type of monolithic (unshaped) material. The numbers refer to the relevant clauses.

Table A.1 — Tests to be performed

Parameter		Chemical analysis	Grain size distribution		Moisture content	Workability	
			Preparation	Procedure			
Castable and gunning materials	Al ₂ O ₃ -SiO ₂	5.2	6.4	6.5	7		
	basic	5.3	6.4	6.5	7		
	special	5.4	6.4	6.5	7		
	carbon-containing	5.5	6.4	6.5	7		
Wet ramming materials	Al ₂ O ₃ -SiO ₂	dry ramming mixes	5.2	6.4	6.5	7	
		others	5.2	6.4	6.5	7	8
	basic	dry ramming mixes	5.3	6.4	6.5	7	
		others	5.3	6.4	6.5	7	
	special	dry ramming mixes	5.4	6.4	6.5	7	
		others	5.4	6.4	6.5	7	8
	carbon-containing	dry ramming mixes	5.5	6.4	6.5	7	
		others	5.5	6.4	6.5	7	8

1927-3:2012(E)

ICS 81.080

Price based on 11 pages