**Rigid cellular plastics — Determination of
tensile properties**

*Plastiques alvéolaires rigides — Détermination des caractéristiques en
traction*



Reference number
ISO 1926:2009(E)

© ISO 2009

Foreword

ISO (the International Organization for Standardization) is a worldwide federation of national standards bodies (ISO member bodies). The work of preparing International Standards is normally carried out through ISO technical committees. Each member body interested in a subject for which a technical committee has been established has the right to be represented on that committee. International organizations, governmental and non-governmental, in liaison with ISO, also take part in the work. ISO collaborates closely with the International Electrotechnical Commission (IEC) on all matters of electrotechnical standardization.

International Standards are drafted in accordance with the rules given in the ISO/IEC Directives, Part 2.

The main task of technical committees is to prepare International Standards. Draft International Standards adopted by the technical committees are circulated to the member bodies for voting. Publication as an International Standard requires approval by at least 75 % of the member bodies casting a vote.

Attention is drawn to the possibility that some of the elements of this document may be the subject of patent rights. ISO shall not be held responsible for identifying any or all such patent rights.

ISO 1926 was prepared by Technical Committee ISO/TC 61, *Plastics*, Subcommittee SC 10, *Cellular plastics*.

This fourth edition cancels and replaces the third edition (ISO 1926:2005), of which it constitutes a minor revision. Changes have been made to the requirements for the conditioning of test specimens in 5.2.

© ISO 2009. All rights reserved

Rigid cellular plastics — Determination of tensile properties

1 Scope

This International Standard specifies a method of determining the behaviour of rigid cellular plastics materials when they are subjected to a tensile stress.

It applies primarily to cellular materials having a compression resistance sufficient to permit suitable gripping of the test specimens. If it is impossible to grip the test specimen, the method is modified so that the ends of the specimen are reinforced with metal plates (see Clause 8).

The relationship between cell size and test specimen size must be such that the test is realistic.

2 Normative references

The following referenced documents are indispensable for the application of this document. For dated references, only the edition cited applies. For undated references, the latest edition of the referenced document (including any amendments) applies.

ISO 291, *Plastics — Standard atmospheres for conditioning and testing*

ISO 5725-2, *Accuracy (trueness and precision) of measurement methods and results — Part 2: Basic method for the determination of repeatability and reproducibility of a standard measurement method*

3 Principle

A test specimen of a given shape is subjected to a tensile stress transmitted to the test specimen by means of a suitable device and corresponding stress-strain curve is plotted.

4 Apparatus

The test machine shall be such that:

- a) It has clamps suitable for holding the test specimen. These clamps shall meet the following requirements:
 - 1) they shall close sufficiently tightly on the faces of the test specimen to avoid slipping;
 - 2) they shall not exert, on any part of the ends of the test specimen, localized pressure which could cause tears, deformations or ruptures.

In cases of difficulty, use the variant described in Clause 8.

- b) The movable clamp can be moved, with the test specimen in place, away from the fixed clamp at a constant speed of (5 ± 1) mm/min in a direction parallel to the longitudinal axis of the test specimen.
- c) The force thus exerted on the test specimen can be determined with a maximum error of 1 %, and can be recorded.

- d) If an extensometer is used, it shall exert a minimum force on the test specimen and shall permit the increase in gauge length of the test specimen to be read to an accuracy of 0,1 mm. The distance between the two parallel surfaces defining the extensometer gauge length shall not vary by more than 1 % (tolerance on parallelism).

5 Test specimens

5.1 Dimensions

The test specimens shall have the shape and dimensions shown in Figure 1.

Dimensions in millimetres

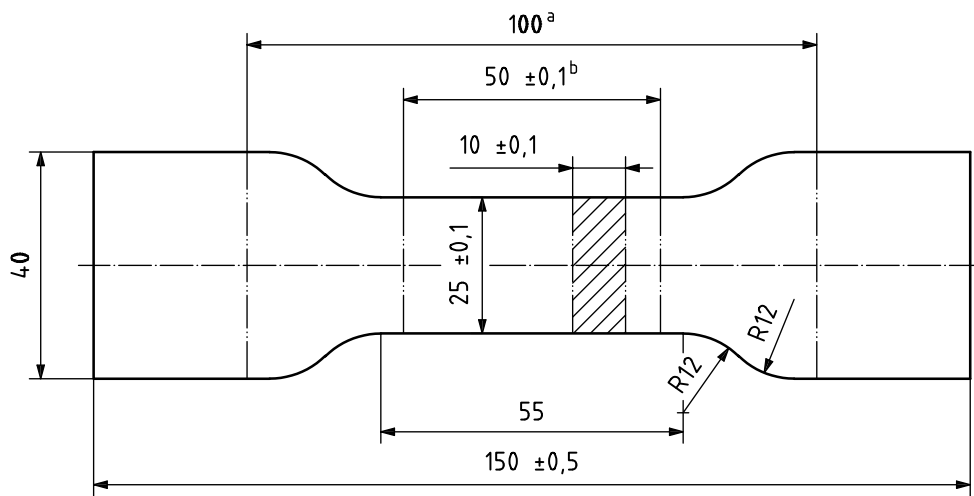

^a Distance between jaws.

^b Gauge length.

Figure 1 — Test specimen

5.2 Preparation and conditioning

Remove any moulding skin from the test specimens, trimming their surfaces with a mechanical saw and, if necessary, machining them, but without modifying the structure.

When necessary, mark the test specimens so as to indicate their orientation in relation to the direction of anisotropy.

The conditioning of the test specimens shall be carried out in accordance with the requirements of ISO 291. For precise measurement, test specimens shall be conditioned for a minimum of 6 h at

$(23 \pm 2) ^\circ\text{C}$ and $(50 \pm 10) \%$ relative humidity

or

$(23 \pm 5) ^\circ\text{C}$ and $(50^{+20}_{-10}) \%$ relative humidity

or

$(27 \pm 5) ^\circ\text{C}$ and $(65^{+20}_{-10}) \%$ relative humidity.

5.3 Number of test specimens

The test shall be carried out on at least five test specimens; any test specimens which break outside the extensometer gauge length shall be rejected and, if necessary, the number of test specimens subjected to the test shall be increased so that the number of significant results is not less than five.

If it is necessary to use more than seven test specimens to obtain five valid readings, use the method described in Clause 8.

6 Procedure (general method)

Carry out the test in a room in which the atmosphere is maintained at one of the sets of conditions defined in 5.2.

Place the test specimen between the clamps. If necessary, proceed in accordance with Clause 8. Mark the original gauge length on the test specimen.

Apply the force to be exerted on the test specimen in such a way that it is uniformly distributed by the movable grip, the rate of displacement of which shall be (5 ± 1) mm/min.

If an extensometer is not used, record the elongation corresponding to a given force at suitable intervals.

Plot the stress-strain curve.

7 Calculation and expression of results

7.1 Elongation

The elongation, e , expressed as a percentage of the original gauge length, is given by the equation

$$e = \frac{\Delta L_0}{L_0} \times 100$$

where

L_0 is the original gauge length of the test specimen, expressed in millimetres;

ΔL_0 is the increase in gauge length of the test specimen corresponding to a given force, measured by the variation in distance between the gauge marks, expressed in millimetres.

Calculate in particular (after determination, from the stress-strain curve, of the corresponding elongations):

- the elongation e_{\max} at the maximum stress (if applicable);
- the elongation e_r at rupture.

7.2 Tensile strength

The maximum tensile stress σ_{\max} (where applicable), expressed in kilopascals, is given by the equation

$$\sigma_{\max} = \frac{F_{\max}}{b \times h} \times 10^3$$

where

F_{\max} is the maximum force applied to the test specimen during the test, expressed in newtons;

b is the original width of the narrow parallel-sided section of the test specimen, expressed in millimetres;

h is the original thickness of the narrow parallel-sided section of the test specimen, expressed in millimetres.

7.3 Breaking stress

The tensile stress at rupture σ_r , expressed in kilopascals, is given by the equation

$$\sigma_r = \frac{F_r}{b \times h} \times 10^3$$

where

F_r is the force applied to the test specimen at the moment of rupture, expressed in newtons;

b and h have the same meaning as in 7.2.

8 Variation: use of metal plates

8.1 General

This variant differs from the general method in that the ends of the test specimens are modified to allow them to be bonded to reinforcing metal plates.

Consequently, follow the directions given in Clauses 4 to 7, taking into account the following modifications.

8.2 Apparatus

8.2.1 Test machine, designed in such a way that:

- a) a test specimen having the shape and dimensions shown in Figure 2 can be held between two clamps each comprising two cylinders of diameter 30 mm orthogonal to the plane of the test specimen, one of the clamps being fixed and the other movable, the force being transmitted equally by each of the four cylinders;
- b) see Clause 4 b);
- c) see Clause 4 c);
- d) see Clause 4 d).

8.2.2 Metal plates, of the form and dimensions shown in Figure 2; four are required for each test specimen subjected to the test. (Plates of aluminium alloy or anodized aluminium are likely to be satisfactory.)

8.2.3 Adhesive, for fixing the metal plates to the test specimens. It shall be such that the shear strength of the adhesive film is greater than that of the cellular material under test, so as to avoid any slipping of the test specimen on the plates. Preliminary tests shall make it possible to verify that the elongation of this film can be disregarded in the determination of the elongation of the test specimen. In addition, the adhesive film shall not appreciably modify the characteristics of the cellular material. (An epoxide resin base adhesive is likely to be satisfactory.)

8.3 Test specimens

8.3.1 Dimensions

The test specimens shall have the shape and the dimensions shown in Figure 2.

8.3.2 Preparation and conditioning

Bond four metal plates to the ends of each test specimen so that the plates exactly cover the ends of the specimen, as shown in Figure 2, in order to reinforce them.

Use a bonding jig which will hold the metal plates firmly in place, face to face, during bonding and during the setting time.

For conditioning of the test specimens, see 5.2.

8.3.3 Number of test specimens

See 5.3.

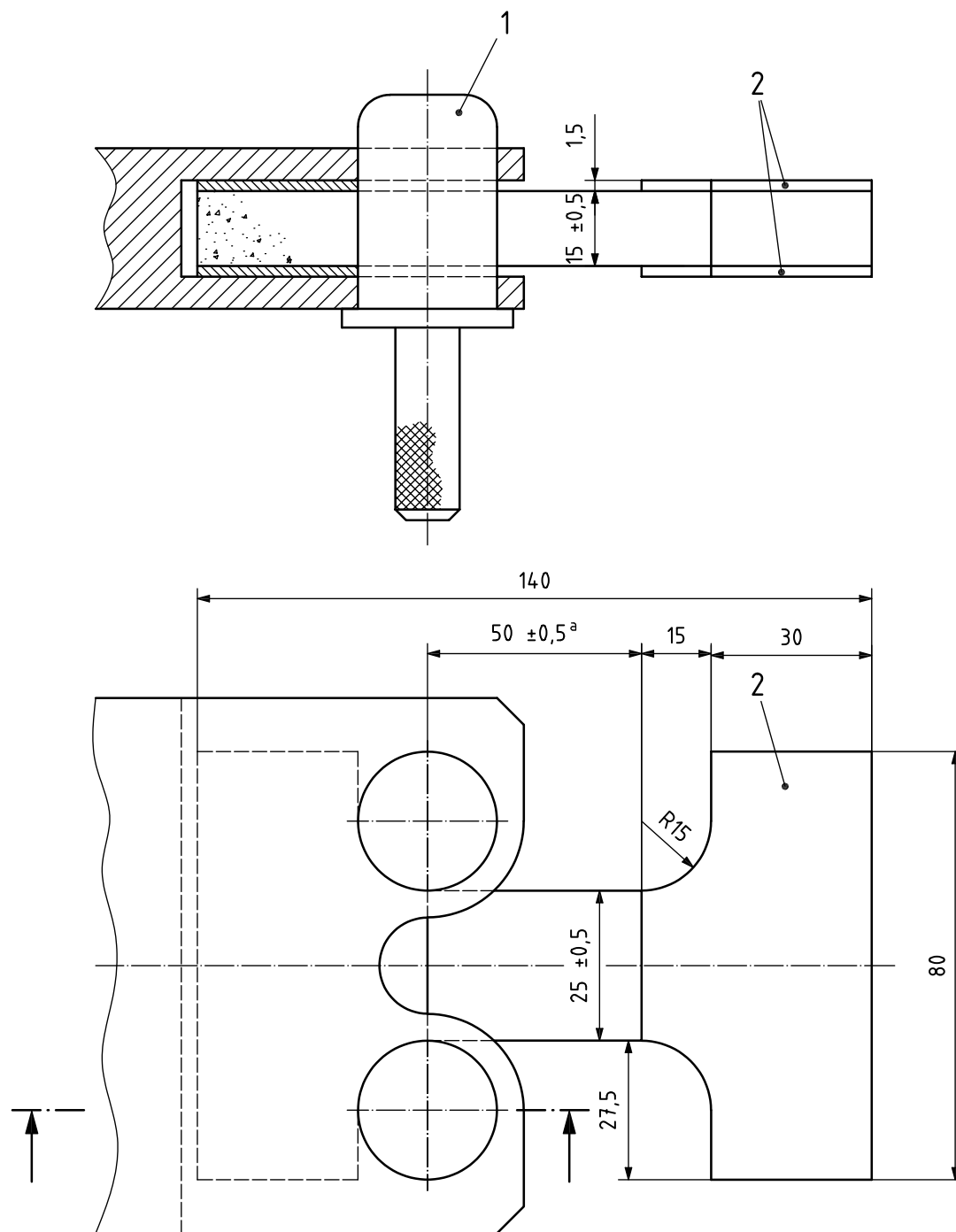

Key

- 1 lower assembly removed
 - 2 metal plates
- ^a Gauge length.

Figure 2 — Test specimen with metal reinforcing plates

8.4 Procedure

Because metal plates are used, the elongation of the test specimen may be measured from the separation of the machine grips.

8.5 Calculation and expression of results

See Clause 7.

9 Precision

An interlaboratory test was performed with 10 laboratories in 1993. Four products with different tensile characteristics were tested, three of which were used for the statistical determination of the reproducibility (two test results for each product), while one product was used for the statistical determination of the repeatability (five test results).

The results, analysed in accordance with ISO 5725-2, are given in Table 1.

Table 1 — Results of interlaboratory tests

95 % reproducibility limit	95 % repeatability limit
Approximately 10 %	Approximately 3 %

10 Test report

The test report shall include the following information:

- a) a reference to this International Standard;
- b) the nature of the material tested;
- c) the conditioning procedure used;
- d) which of the two types of test specimen were used (if the variant described in Clause 8 was used, state clearly: "metal plates used");
- e) the number of test specimens tested;
- f) where applicable, the direction of the tensile force in relation to the direction of anisotropy;
- g) the individual results, calculated using the equations given in Clause 7, and their average;
- h) the stress-strain curve;
- i) any deviation from the method specified;
- j) the date of the test.

ICS 83.100

Price based on 7 pages