Testing of concrete —

Part 5:

**Properties of hardened concrete other
than strength**

Essais du béton —

Partie 5: Caractéristiques du béton durci autres que la résistance



Reference number
ISO 1920-5:2004(E)

© ISO 2004

PDF disclaimer

This PDF file may contain embedded typefaces. In accordance with Adobe's licensing policy, this file may be printed or viewed but shall not be edited unless the typefaces which are embedded are licensed to and installed on the computer performing the editing. In downloading this file, parties accept therein the responsibility of not infringing Adobe's licensing policy. The ISO Central Secretariat accepts no liability in this area.

Adobe is a trademark of Adobe Systems Incorporated.

Details of the software products used to create this PDF file can be found in the General Info relative to the file; the PDF-creation parameters were optimized for printing. Every care has been taken to ensure that the file is suitable for use by ISO member bodies. In the unlikely event that a problem relating to it is found, please inform the Central Secretariat at the address given below.

© ISO 2004

All rights reserved. Unless otherwise specified, no part of this publication may be reproduced or utilized in any form or by any means, electronic or mechanical, including photocopying and microfilm, without permission in writing from either ISO at the address below or ISO's member body in the country of the requester.

ISO copyright office
Case postale 56 • CH-1211 Geneva 20
Tel. + 41 22 749 01 11
Fax + 41 22 749 09 47
E-mail copyright@iso.org
Web www.iso.org

Published in Switzerland

Contents

Page

Foreword	iv
1 Scope	1
2 Normative references	1
3 Definitions	1
4 Determination of density of hardened concrete	1
4.1 General	1
4.2 Apparatus	1
4.3 Test specimens	2
4.4 Procedures	2
4.5 Test result	4
4.6 Test Report	5
5 Determination of the depth of penetration of water under pressure	6
5.1 Principle	6
5.2 Apparatus	6
5.3 Test specimen	8
5.4 Procedure	8
5.5 Test result	9
5.6 Test report	9
6 Test report	9
Annex A (informative) Precision for the method of determination of the density	10
Annex B (informative) Example of test reports	11

Foreword

ISO (the International Organization for Standardization) is a worldwide federation of national standards bodies (ISO member bodies). The work of preparing International Standards is normally carried out through ISO technical committees. Each member body interested in a subject for which a technical committee has been established has the right to be represented on that committee. International organizations, governmental and non-governmental, in liaison with ISO, also take part in the work. ISO collaborates closely with the International Electrotechnical Commission (IEC) on all matters of electrotechnical standardization.

International Standards are drafted in accordance with the rules given in the ISO/IEC Directives, Part 2.

The main task of technical committees is to prepare International Standards. Draft International Standards adopted by the technical committees are circulated to the member bodies for voting. Publication as an International Standard requires approval by at least 75 % of the member bodies casting a vote.

Attention is drawn to the possibility that some of the elements of this document may be the subject of patent rights. ISO shall not be held responsible for identifying any or all such patent rights.

ISO 1920-5 was prepared by Technical Committee ISO/TC 71, *Concrete, reinforced concrete and pre-stressed concrete*, Subcommittee SC 1, *Test methods for concrete*.

This first edition of ISO 1920-5 cancels and replaces ISO 6275:1982 which has been technically revised.

ISO 1920 consists of the following parts, under the general title *Testing of concrete*:

- *Part 1: Sampling of fresh concrete*
- *Part 2: Properties of fresh concrete*
- *Part 3: Making and curing test specimens*
- *Part 5: Properties of hardened concrete other than strength*
- *Part 6: Sampling, preparing and testing concrete cores*
- *Part 7: Non-destructive tests of hardened concrete*

Part 4, *Strength of hardened concrete*, is in preparation.

Testing of concrete —

Part 5: Properties of hardened concrete other than strength

1 Scope

This part of ISO 1920 specifies procedures for testing properties of hardened concrete other than strength.

2 Normative references

The following referenced document is essential for the application of this document. For undated references, the latest edition of the referenced document (including any amendments) applies.

ISO 1920-3, *Testing Concrete — Part 3: Making and curing test specimens*

3 Definitions

For the purpose of this document, the following definition applies.

3.1

density

ratio of the mass of a given quantity of hardened concrete to its volume

NOTE The density is expressed in kilograms per cubic metre.

4 Determination of density of hardened concrete

4.1 General

This test method is applicable to lightweight, normal-weight and heavy-weight concrete.

It differentiates between hardened concrete in the following states:

- as-received;
- saturated;
- oven-dried.

The mass and the volume of the specimen of hardened concrete are determined and the density calculated.

4.2 Apparatus

4.2.1 Callipers and rules, capable of determining the dimensions of a specimen to within $\pm 0,5$ %.

4.2.2 Balance. equipped with a stirrup for weighing the specimen in both air and water to an accuracy of 0,1 % of the mass (see Figure 1).

4.2.3 Water tank, fitted with a device to maintain the water at a constant level and of sufficient size to allow the specimen on the stirrup to be fully immersed to constant depth (see Figure 1).

4.2.4 Ventilated oven, for which the temperature can be maintained at $105\text{ °C} \pm 5\text{ °C}$.

4.3 Test specimens

The minimum volume of a specimen shall be 1 l. If the nominal maximum aggregate size exceeds 25 mm, the minimum volume of the specimen, in cubic millimetres, shall be not less than $50D^3$, where D is the nominal maximum size of the coarse aggregate.

Normally, the entire specimen as received should be used for the determination of the density.

If the shape or size of a specimen is such that it is not possible to use all of it, a smaller specimen, conforming to the requirements given above, may be sawn from the original.

4.4 Procedures

4.4.1 General

4.4.1.1 Calibration of the apparatus

The apparatus used shall be in calibration at time of use. The balance, the device for weighing specimens in water and the oven should be calibrated at least once per year.

4.4.1.2 Determination of mass

This part of ISO 1920 permits three conditions under which the mass of a specimen can be determined:

- a) as-received;
- b) water-saturated;
- c) oven-dried.

4.4.1.3 Determination of volume

This part of ISO 1920 permits three methods for determining the volume of the specimen:

- a) by water displacement (reference method);
- b) by calculation, using actual measurements;
- c) for cubes, by calculation, using checked designated dimensions.

4.4.2 Mass of as-received specimen

Weigh the as-received specimen, to an accuracy of 0,1 % of the mass of the specimen.

Record the value, expressed in kilograms, as m_r .

4.4.3 Mass of water-saturated specimen

Immerse the specimen in water at $20\text{ °C} \pm 2\text{ °C}$ until the mass changes by less than 0,2 % in 24 h. Before each weighing, wipe the surplus water from the surface using a moist cloth.

Specimens of normal-weight concrete cured in water continuously for at least 72 h prior to testing may be assumed to satisfy this requirement.

Record the value, expressed in kilograms, of saturated mass as m_s .

4.4.4 Mass of oven-dried specimen

Dry the specimen in a ventilated oven at $105\text{ °C} \pm 5\text{ °C}$ until the mass changes by less than 0,2 % in 24 h.

Before each weighing, cool the specimen to near room temperature in a dry airtight vessel or desiccator.

Record the value, expressed in kilograms, of the oven-dried mass as m_o .

4.4.5 Volume obtained by water displacement

4.4.5.1 General

This method is suitable for specimens of all shapes and is the only method suitable for specimens of irregular shape.

The specimen shall be in a saturated condition.

This method is not suitable for specimens of no-fines concrete, concrete made with lightweight aggregate that floats in water, concrete with large pores, or specimens the moisture content of which is not to be altered. However, if an impermeable layer is applied to the specimen, this method may be used.

4.4.5.2 Mass in water

Allow the hydrostatic device of the balance to reach equilibrium. Ensure that the empty stirrup hanging from the balance is completely immersed in the water tank and that the stirrup is not touching the bottom of the tank.

Record the depth of the immersion of the stirrup and the apparent mass, in kilograms, of the stirrup as m_{st} .

Place the specimen in the stirrup and fully immerse in water to the same depth as the empty stirrup.

Take care to avoid trapping air bubbles on the sides of the sample and on the stirrup.

Weigh the completely immersed specimen and stirrup. Record $(m_{st} + m_w)$, the apparent mass, in kilograms.

4.4.5.3 Mass in air

Remove the specimen from the stirrup, and wipe the surplus water from the surfaces using a damp cloth. Weigh the specimen on the balance.

Record the mass, in kilograms, of the specimen in air as m_a .

4.4.5.4 Calculation of volume

Calculate the volume of the specimen using Equation (1):

$$V = \frac{m_a - [(m_{st} + m_w) - m_{st}]}{\rho_w} \quad (1)$$

where

V is the volume, in cubic metres, of the specimen;

m_a is the mass, in kilograms, of the specimen in air;

m_{st} is the apparent mass, in kilograms, of the immersed stirrup,;

m_w is the apparent mass, in kilograms, of the immersed specimen;

ρ_w is the density of water, in kilograms per cubic metre, at 20 °C, taken as 998 kg/m³.

4.4.6 Volume, using actual measurements

Only undamaged, prismatic, or cylindrical specimens shall be used for the calculation of volume.

Where there is no documentation to show that a specimen has been cast in a calibrated mould, each dimension shall be measured in accordance with ISO 1920-3.

The average of the actual measurements taken and recorded for each dimension shall be used to calculate the volume, V , in cubic metres, of the specimen, rounded to four significant figures.

4.4.7 Volume, using checked designated dimensions

Only undamaged, prismatic, or cylindrical specimens shall be used for the calculation of volume.

Where specimens have documentation to show that they have been made in calibrated moulds (see ISO 1920-3), it shall be necessary only to check that each dimension is within $\pm 0,5$ % of the designated size.

The volume, V , of the specimen shall be calculated from the designated dimensions, and expressed in cubic metres, rounded to four significant figures.

4.5 Test result

Calculate the density using the value determined for the mass of specimen and its volume, using Equation (2):

$$D = \frac{m}{V} \quad (2)$$

where

D is the density, in kilograms per cubic metre, related to the condition of the specimen and the method of determining the volume;

m is the mass, in kilograms, of the specimen in its condition at the time of test;

V is the volume, in cubic metres, determined by the particular method.

Report the condition of the specimen at the time of test (see 4.4.1.2) and the method used for determining the volume of the specimen (see 4.4.1.3).

Express the result of the density determination to the nearest 10 kg/m³.

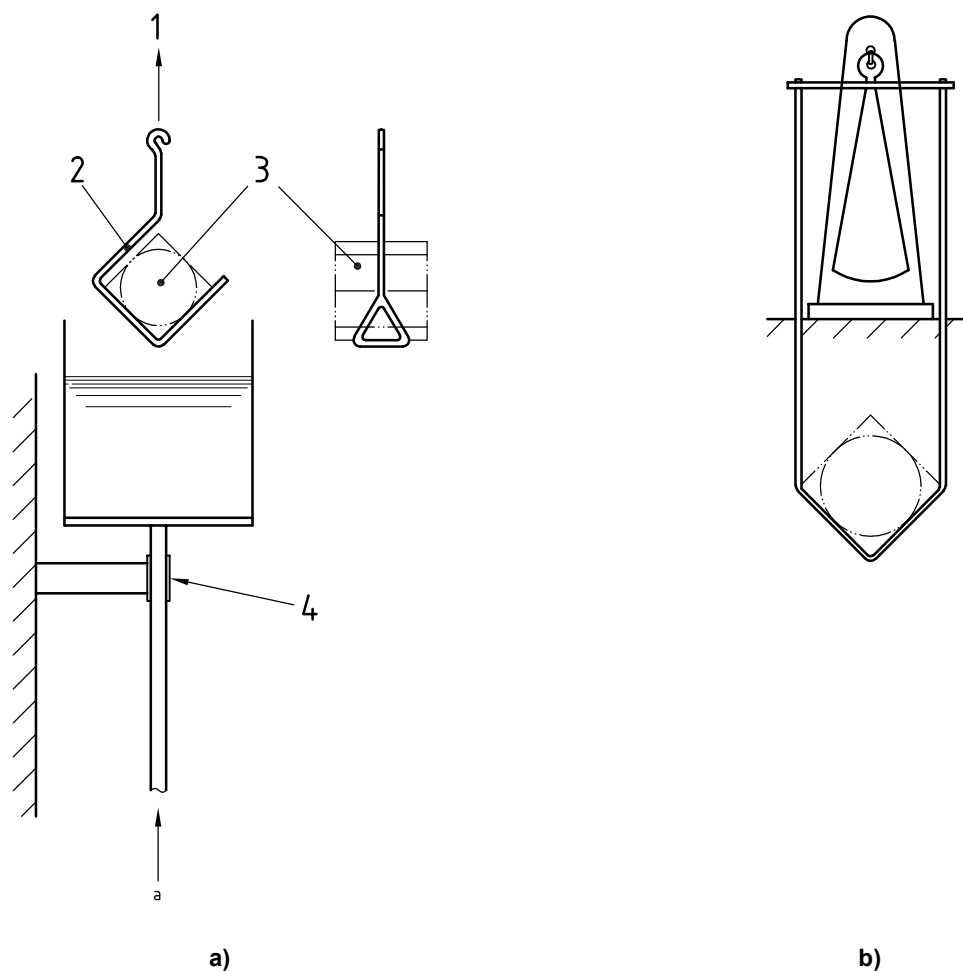

Key

- 1 balance
- 2 stirrup
- 3 concrete specimen
- 4 guide
- a Water tank is moved vertically.

Figure 1 — Typical stirrup arrangement for the determination of the volume of concrete specimens by water displacement — Stirrup suspended beneath the balance mechanism a) and alternate form of stirrup suspended above the balance mechanism b)

4.6 Test Report

In addition to the requirements in Clause 6, the test report shall include the following:

- description of the specimen (e.g. 100 mm cube, 150 mm diameter core);
- condition of specimen at time of test (as-received/saturated/oven-dried);
- time/date of determination of mass and volume;
- mass of specimen;
- method of determination of volume (checked designated size/measured size/water displacement);
- volume of specimen;

— calculated density of specimen.

5 Determination of the depth of penetration of water under pressure

5.1 Principle

The method determines the depth of penetration of water under pressure in hardened concrete that has been water-cured.

Water is applied under pressure to the surface of hardened concrete. The specimen is then split and the depth of penetration of the water front is recorded and measured.

5.2 Apparatus

5.2.1 Testing equipment, which shall consist of any equipment in which the test specimen, of given dimensions, is placed in such a manner that the water pressure can act on the test area and the continuously pressure applied displayed.

An example of a test arrangement is shown in Figure 2.

It is preferable that the apparatus allow the other faces of the test specimen to be observed.

The water pressure may be applied to the surface of the test specimen either from the bottom or the top.

A suitable seal, made of rubber or other similar material, shall be used to provide the necessary sealing.

The dimension of the test area shall be approximately half of the length of the edge or diameter of the test surface.

5.2.2 Wire brush

Dimensions in millimetres

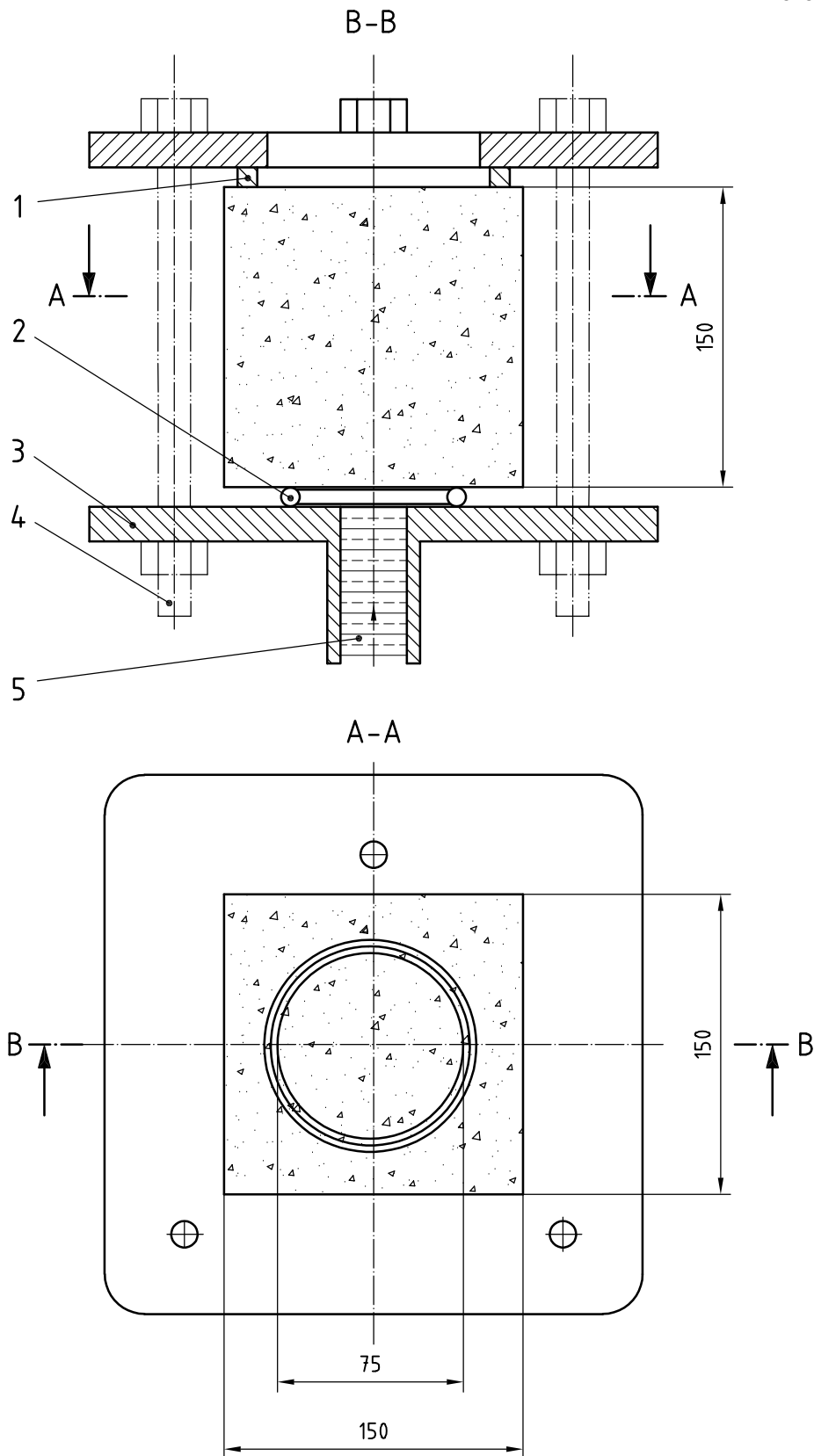

Key

- | | | | |
|---|------------------|---|----------------------|
| 1 | packing piece | 4 | screw-threaded rod |
| 2 | sealing ring | 5 | water under pressure |
| 3 | screwed on plate | | |

Figure 2 — Example of test arrangement

5.3 Test specimen

The specimen shall be cubic, cylindrical or prismatic of edge length, or diameter not less than 150 mm. Cored and sawn specimens may also be used.

The ratio of the height to the length of the edge (or height-to-diameter) shall be greater than or equal to 0,5, but the height shall be not less than 100 mm.

Whilst specimen dimensions should generally be in accordance with ISO 1920-3, the tolerances are unimportant for this test.

5.4 Procedure

5.4.1 Preparation of the test specimen

The test specimen shall be water-cured in accordance with ISO 1920-3.

Start the test when the specimens are at least 28 days old. Immediately after the specimen is demoulded, roughen the surface to be exposed to water pressure with a wire brush.

5.4.2 Application of water pressure

The water used shall be potable tap water.

Place the specimen in the apparatus and apply a water pressure of $500 \text{ kPa} \pm 50 \text{ kPa}$ for the duration of $72 \text{ h} \pm 2 \text{ h}$.

Do not apply the water pressure to a trowelled surface of a specimen.

During the test, periodically observe the appearance of the surfaces of the test specimen not exposed to the water pressure to note the presence of water. If leakage is observed, then record the fact and consider the validity of the result.

5.4.3 Examination of specimen

After the pressure has been applied for $72 \text{ h} \pm 2 \text{ h}$, remove the specimen from the apparatus. Wipe the face on which the water pressure was applied to remove excess of water.

Immediately split the specimen in half, perpendicular to the face on which the water pressure was applied. When splitting the specimen, and during the examination, place the face of the specimen exposed to the water pressure on the bottom.

As soon as the split face has dried to such an extent that the water penetration front can be clearly seen, mark the water front on the specimen.

The water front should be compared with the acceptable water penetration fronts (see Figure 3).

If the water front is acceptable, measure the maximum depth of penetration under the test area and record it to the nearest millimetre.

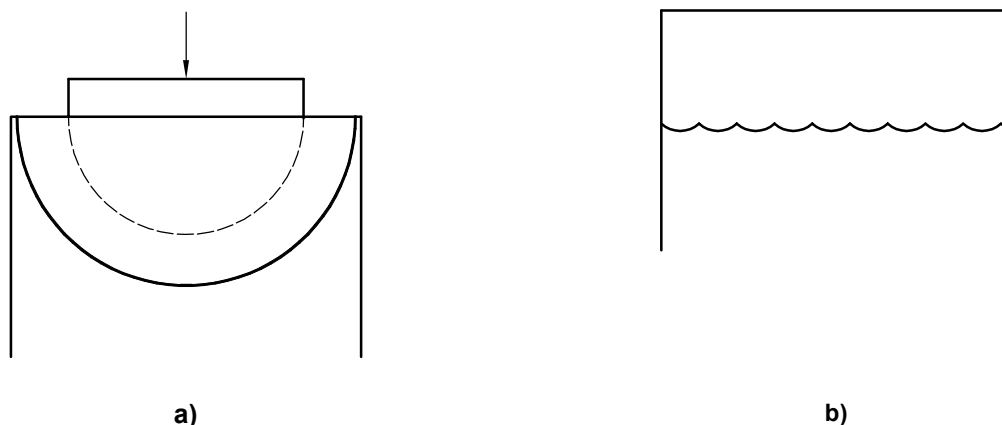

Figure 3 — Water fronts — Acceptable a) and unacceptable b)

5.5 Test result

The maximum depth, expressed to the nearest millimetre, of penetration is the test result.

5.6 Test report

In addition to the requirements in Clause 6, the test report shall include the following:

- date of start of the test;
- direction of application of water pressure (on top or bottom of the specimen perpendicular to or parallel to the direction of casting);
- any deviation of the water penetration front from the acceptable ones;
- maximum depth of penetration, in mm;
- any leakage and consideration of the validity of the result (if appropriate);
- the penetration front curve;
- the age of the specimen when tested.

6 Test report

The test report shall include, in addition to the requirements for each test method, the following:

- a) identification of the test specimen;
- b) location of the test site;
- c) time/date of receipt of the specimen;
- d) any deviation from the standard test methods;
- e) declaration by the person technically responsible for the test that it was carried out in accordance with this part of ISO 1920-5, except as noted in 6 d);

Annex A (informative)

Precision for the method of determination of the density

Precision data are given in Table A.1. These apply to density measurements in the range 2 300 kg/m³ to 2 400 kg/m³ made on cubes of concrete taken from the same sample and under the conditions that each test result is obtained from a single determination of the saturated density of a single cube. They indicate the variability that occurs when sampling, making and curing the cubes (in accordance with ISO 1920-3), as well as in the measurement of their densities.

Table A.1 — Precision data for measurements of the saturated density of hardened concrete

Test Method	Repeatability conditions		Reproducibility conditions	
	s_r kg/m ³	r kg/m ³	s_R kg/m ³	R kg/m ³
By calculation:				
100 mm cubes	13,9	39	20,5	57
150 mm cubes	9,9	28	20,5	57
By water displacement:				
100 mm cubes	6,5	18	12,8	36
150 mm cubes	6,4	18	10,6	30

NOTE 1 The difference between two test results from the same sample by one operator using the same apparatus within the shortest feasible time interval will exceed the repeatability value r on average not more than once in 20 cases in the normal and correct operation of the method.

NOTE 2 Test results on the same sample obtained within the shortest feasible time interval by two operators each using their own apparatus will differ by the reproducibility value R on average not more than once in 20 cases in the normal and correct operation of the method.

NOTE 3 For further information on precision, and for definitions of the statistical terms used in connection with precision, see ISO 5725¹⁾.

1) ISO 5725 (all parts), *Accuracy (trueness and precision) of measurement methods and results*.

Annex B (informative)

Example of test reports

B.1 Example of test report of the density of hardened concrete

Client

Test organisation

Accreditation test report ref

Test Location

Sample

Specimen identification: _____ Date and time received: _____
 Description of specimen: _____
 abnormalities: _____
 Details of specimen preparation: _____
 Date/time of determination of mass and volume: _____

Determination of mass

Condition of specimen at time of test: as received/saturated/oven-dried:

Mass of specimen (kg)(m_a , m_s or m_o):

kg

Determination of volume

Method of determination of volume: checked designated size/actual (measured) size/displacement*

Checked designated size²⁾

Reference to mould calibration

Confirmation measurements: × × mm

Actual measurements²⁾

Dimension measured: × × mm

Volume of specimen:

m³

2) Delete as appropriate.

Water displacement²⁾

Apparent mass of stirrup immersed	(m_{st}):	kg
Apparent mass of stirrup + specimen immersed	($m_{st} + m_w$):	kg
Apparent mass of specimen	(m_w):	kg
Mass of specimen in air	(m_a):	kg

Volume of specimen = $\frac{m_a - [(m_{st} + m_w) - m_{st}]}{998}$. m³

Determination of density

Density of specimen in as-received/saturated/over dry condition with volume determination by checked designated size/actual size/displacement*

$D = \frac{m}{V}$: kg/m³

Except as detailed above this test was carried out in accordance with ISO 1920-5

Technical Responsibility

Responsible person: Name: Position:

Signature:

Test report identification

Test report No: Date issued:



ICS 91.100.30

Price based on 13 pages