

---

---

**Testing of concrete —**

**Part 3:**

**Making and curing test specimens**

*Essais du béton —*

*Partie 3: Confection et prise des éprouvettes*



Reference number  
ISO 1920-3:2004(E)

© ISO 2004

**PDF disclaimer**

This PDF file may contain embedded typefaces. In accordance with Adobe's licensing policy, this file may be printed or viewed but shall not be edited unless the typefaces which are embedded are licensed to and installed on the computer performing the editing. In downloading this file, parties accept therein the responsibility of not infringing Adobe's licensing policy. The ISO Central Secretariat accepts no liability in this area.

Adobe is a trademark of Adobe Systems Incorporated.

Details of the software products used to create this PDF file can be found in the General Info relative to the file; the PDF-creation parameters were optimized for printing. Every care has been taken to ensure that the file is suitable for use by ISO member bodies. In the unlikely event that a problem relating to it is found, please inform the Central Secretariat at the address given below.

© ISO 2004

All rights reserved. Unless otherwise specified, no part of this publication may be reproduced or utilized in any form or by any means, electronic or mechanical, including photocopying and microfilm, without permission in writing from either ISO at the address below or ISO's member body in the country of the requester.

ISO copyright office  
Case postale 56 • CH-1211 Geneva 20  
Tel. + 41 22 749 01 11  
Fax + 41 22 749 09 47  
E-mail [copyright@iso.org](mailto:copyright@iso.org)  
Web [www.iso.org](http://www.iso.org)

Published in Switzerland

# Contents

Page

Foreword.....	iv
<b>1 Scope.....</b>	<b>1</b>
<b>2 Normative references .....</b>	<b>1</b>
<b>3 Terms and definitions .....</b>	<b>1</b>
<b>4 Shape, dimensions and tolerances of specimens and moulds .....</b>	<b>2</b>
4.1 General .....	2
4.2 Cubes .....	2
4.3 Cylinders .....	2
4.4 Prisms .....	4
<b>5 Apparatus.....</b>	<b>4</b>
5.1 Apparatus for measuring the test specimens.....	4
5.2 Apparatus for making test specimens.....	5
<b>6 Preparation of test specimens.....</b>	<b>6</b>
6.1 Sampling .....	6
6.2 Preparation and filling of the mould .....	6
6.3 Compaction of the concrete.....	6
6.4 Surface levelling.....	6
6.5 Marking.....	6
<b>7 Curing of test specimens .....</b>	<b>6</b>
<b>8 Measurement of dimensions and shape.....</b>	<b>7</b>
8.1 Specimens made in calibrated moulds.....	7
8.2 Specimens made in uncalibrated moulds .....	7
<b>9 Report.....</b>	<b>7</b>
<b>Annex A (informative) Wet sieving of concrete .....</b>	<b>9</b>
<b>Annex B (informative) Application of ISO 1101 to concrete test specimens and moulds .....</b>	<b>10</b>
<b>Annex C (normative) Lightweight cylindrical moulds .....</b>	<b>12</b>
<b>Annex D (normative) Methods of compaction.....</b>	<b>18</b>
<b>Annex E (informative) Example of specimen preparation test report.....</b>	<b>19</b>
<b>Bibliography .....</b>	<b>20</b>

## Foreword

ISO (the International Organization for Standardization) is a worldwide federation of national standards bodies (ISO member bodies). The work of preparing International Standards is normally carried out through ISO technical committees. Each member body interested in a subject for which a technical committee has been established has the right to be represented on that committee. International organizations, governmental and non-governmental, in liaison with ISO, also take part in the work. ISO collaborates closely with the International Electrotechnical Commission (IEC) on all matters of electrotechnical standardization.

International Standards are drafted in accordance with the rules given in the ISO/IEC Directives, Part 2.

The main task of technical committees is to prepare International Standards. Draft International Standards adopted by the technical committees are circulated to the member bodies for voting. Publication as an International Standard requires approval by at least 75 % of the member bodies casting a vote.

Attention is drawn to the possibility that some of the elements of this document may be the subject of patent rights. ISO shall not be held responsible for identifying any or all such patent rights.

ISO 1920-3 was prepared by Technical Committee ISO/TC 71, *Concrete, reinforced concrete and prestressed concrete*, Subcommittee SC 1, *Test methods for concrete*.

This first edition of ISO 1920-3 cancels and replaces ISO 1920:1976 and ISO 2736-2:1986 which have been technically revised.

ISO 1920 consists of the following parts, under the general title *Testing of concrete*:

- *Part 1: Sampling of fresh concrete*
- *Part 2: Properties of fresh concrete*
- *Part 3: Making and curing test specimens*
- *Part 4: Strength of hardened concrete*
- *Part 5: Properties of hardened concrete other than strength*
- *Part 6: Sampling, preparing and testing of concrete cores*
- *Part 7: Non-destructive tests on hardened of concrete*



# Testing of concrete —

## Part 3: Making and curing test specimens

**WARNING** — Some concrete specimens might be too heavy for one person to carry and it is necessary that appropriate means be arranged to carry them.

The use of vibrating equipment, such as vibration tables, can cause damage to joints and loss of sensation due to nerve damage. It is necessary that moulds, density containers, etc. be clamped to the table and not held in position using one's hands while they are being vibrated.

### 1 Scope

This part of ISO 1920 specifies the shape and dimensions of concrete test specimens for strength tests and the methods of making and curing these test specimens.

### 2 Normative references

The following referenced documents are essential for the application of this document. For dated references, only the edition cited applies. For undated references, the latest edition of the referenced document (including any amendments) applies.

ISO 1920-1, *Testing of concrete — Part 1: Sampling of fresh concrete*

ISO 1101:1983, *Technical drawings — Geometrical tolerancing — Tolerancing of form, orientation, location and run-out — Generalities, definitions, symbols, indications on drawings*

### 3 Terms and definitions

For the purpose of this document, the terms and definitions given in ISO 1101:1983 and the following apply.

#### 3.1

##### **nominal sizes of specimens**

range of commonly used specimen sizes amongst which a preferred size is specified in this part of ISO 1920

#### 3.2

##### **designated size of specimens**

specimen size selected and declared by the user of this part of ISO 1920 from amongst the permitted range of nominal sizes

**NOTE** The size of specimens is designated in millimetres.

## 4 Shape, dimensions and tolerances of specimens and moulds

### 4.1 General

For each shape of test specimen, e.g. cube, cylinder, and prism, the basic dimensions,  $l$  or  $d$ , should be chosen to be at least four times the maximum size of the aggregate in the concrete.

NOTE A procedure for wet screening as described in Annex A can be used when the maximum size of the aggregate is larger than  $1/4$  of the basic dimension,  $l$  or  $d$ .

### 4.2 Cubes

#### 4.2.1 Nominal sizes

The nominal sizes are as shown in Figure 1, where  $l$  ( $= l_1$  or  $l_2$  or  $l_3$ ) equals 100 mm, 120 mm, 150 mm, 200 mm, 250 mm or 300 mm.

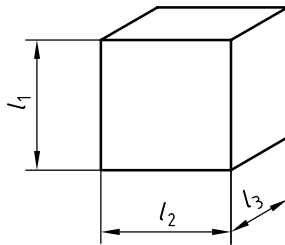

Figure 1 — Nominal sizes of a cube

The preferred sizes are 100 mm and 150 mm.

#### 4.2.2 Designated sizes

The designated size shall be selected from one of the nominal sizes given in 4.2.1.

#### 4.2.3 Tolerances

The following tolerances apply.

- The tolerance on the designated size shall be  $\pm 0,5 \%$ .
- The tolerance on the flatness of the load-bearing surfaces shall be  $\pm 0,000 5 l$ , expressed in millimetres.
- The load-bearing surfaces shall be parallel to a tolerance of not greater than 1,0 mm.
- The tolerance on the perpendicularity of the sides of the cube with reference to the base shall be  $\pm 0,5$  mm.

For the definitions of flatness, parallelism, perpendicularity and straightness, see Annex B.

### 4.3 Cylinders

#### 4.3.1 Nominal sizes

The nominal sizes are as shown in Figure 2, where  $d$  equals 100 mm, 113 mm, 125 mm, 150 mm, 200 mm, 250 mm or 300 mm.

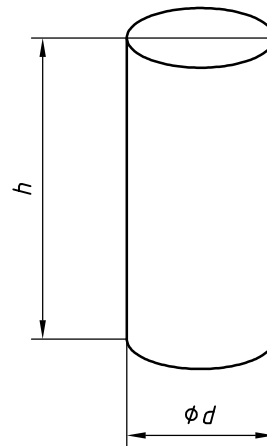

**Figure 2 — Nominal sizes of a cylinder**

NOTE The diameter of 113 mm corresponds to a load-bearing area of 10 000 mm<sup>2</sup>.

The preferred sizes are 100 mm × 200 mm, 125 mm × 250 mm and 150 mm × 300 mm.

The height,  $h$ , of the cylinder shall be  $2d$  except for specimens used for the tensile splitting test. In the latter case, the height of the specimen shall be between  $d$  and  $2d$ .

#### 4.3.2 Designated sizes

Designated sizes may be selected within  $\pm 10\%$  of a nominal size.

#### 4.3.3 Tolerances

The following tolerances apply.

- a) The tolerance on the designated diameter,  $d$ , shall be  $\pm 0,5\%$ .
- b) The tolerance on the flatness of the load-bearing surfaces shall be  $\pm 0,000\ 5\ d$ , expressed in millimetres, except for cylinders tested by unbonded capping methods.
- c) The tolerance on the flatness of the load-bearing surfaces of cylinders tested by unbonded capping methods, such as sand box or elastomeric pads, shall be  $\pm 0,02\ d$ , expressed in millimetres.
- d) The load-bearing surfaces shall be parallel to a tolerance of not greater than 1,0 millimetres.
- e) The tolerance on the perpendicularity of the sides of the cylinder with reference to the end faces shall be  $\pm 0,5\text{ mm}$ .
- f) The tolerance on the height,  $h$ , of the cylinders shall be  $\pm 5\%$ .
- g) The straightness tolerance on any surface parallel to the centre line of the cylinders to be used in compression tests shall be  $\pm 0,5\text{ mm}$ .
- h) The straightness tolerance of any surface parallel to the centre line of the cylinders to be used in tensile splitting tests shall be  $\pm 0,2\text{ mm}$ .

## 4.4 Prisms

### 4.4.1 Nominal sizes

The nominal sizes are as shown in Figure 3, where  $l$  ( $=l_1$  or  $l_2$ ) equals 100 mm, 150 mm, 200 mm, 250 mm or 300 mm and  $L \geq 3,5 l$ .

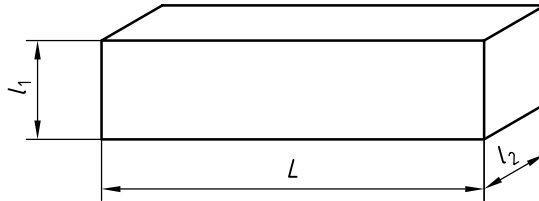

Figure 3 — Nominal sizes of prisms

The preferred sizes are  $l = 100$  mm and  $L = 400$  mm or  $l = 150$  mm and  $L = 600$  mm.

### 4.4.2 Designated sizes

The designated depth,  $l_1$ , and width,  $l_2$ , of prisms shall be selected from one of the nominal sizes given in 4.4.1.

The designated length,  $L$ , of prisms shall be not less than  $3,5 l$ .

### 4.4.3 Tolerances

The following tolerances apply.

- The tolerance on the designated depth,  $l_1$ , and width,  $l_2$ , shall be  $\pm 0,5 \%$ .
- The tolerance on the designated length,  $L$ , shall be  $\pm 5 \%$ .
- The load-bearing surfaces shall be parallel to a tolerance not greater than 1,0 mm.
- The tolerance on the perpendicularity of the sides of the prism with reference to the base shall be  $\pm 0,5$  mm.
- The tolerance on the straightness of the load-bearing area for specimens to be used for bending (flexural) tests shall be  $\pm 0,2$  mm.

## 5 Apparatus

### 5.1 Apparatus for measuring the test specimens.

**5.1.1 Callipers and/or rules**, capable of establishing that the relevant dimensions of specimens or moulds are within  $\pm 0,5 \%$  of the dimension.

**5.1.2 Gauge**, capable of establishing that the relevant flatness of specimens or moulds is within  $\pm 0,000 5 l$  or  $d$ .

**5.1.3 Squares and gauges** (or other similar means), capable of establishing the perpendicularity and parallelism of specimens and moulds within  $\pm 0,5$  mm.



## 5.2 Apparatus for making test specimens

**5.2.1 Moulds**, capable of providing test specimens with the dimensions and tolerances that conform to this part of ISO 1920.

The moulds shall be made of steel or cast-iron, which shall be the reference materials. If moulds are manufactured from other materials, performance test data shall be available that demonstrate equivalence with the steel or cast-iron moulds. Lightweight cylindrical moulds shall conform to the requirements in Annex C.

Moulds shall be watertight and shall be non-absorbent.

Moulds shall be checked at intervals of not more than 1 year. If the mould is in calibration at time of use, the checking of parallelism, verticality and flatness of specimens is not required, provided the size measurements are within tolerance.

Individual moulds shall be identifiable. The designation should be an identification number either welded on the mould body or securely tagged to the moulds.

**5.2.2 Filling frame**, fitted tightly to the mould and used to simplify the filling of the moulds.

The use of a filling frame is optional, but if used, this shall be stated in the test report (see Clause 9).

**5.2.3 Means of compacting the concrete in the mould**, which shall be one of the following:

**5.2.3.1 internal vibrator**, with a minimum frequency of 120 Hz (7 200 cycles per minutes). The diameter of the tube shall not exceed one-quarter of the smallest dimension of the test specimen;

**5.2.3.2 vibrating table**, with a minimum frequency of 40 Hz (2 400 cycles per minute);

**5.2.3.3 compacting rod**, of circular cross-section, straight, made of steel, having a diameter of 16 mm  $\pm$  1 mm and a length of 600 mm  $\pm$  5 mm, and with rounded, roughly hemispherical, ends;

**5.2.3.4 compacting bar**, made of steel having a square or circular cross-section and a mass greater than 1,8 kg.

**5.2.4 General tools**, including the following:

- a) **scoop**, approximately 100 mm wide;
- b) **steel floats**, two;
- c) **sampling tray**, with minimum dimensions of 900 mm  $\times$  900 mm  $\times$  50 mm deep, of rigid construction and made from a non-absorbent material not readily attacked by cement paste;
- d) **shovel**, square-bladed;
- e) **release material**, non-reactive;
- f) **mallet**;
- g) **timer**, having an accuracy of  $\pm$  1 s;

## 6 Preparation of test specimens

### 6.1 Sampling

The samples shall be taken in accordance with ISO 1920-1.

The samples shall be remixed before filling the mould. Concrete mixed in a laboratory need not be remixed.

### 6.2 Preparation and filling of the mould

Before filling, cover the inner surface of the mould with a thin film of mineral oil or any other material to prevent the concrete from adhering to the mould.

Place the mould on a firm and level area.

If a filling frame is used, the amount of concrete used to fill the mould shall be such that a layer of concrete remains in the filling frame after compaction. The thickness of this layer shall be 10 % to 20 % of the height of the test specimen.

Place the concrete in the mould by means of a scoop, in such a way as to remove as much entrapped air as possible (without significantly reducing the amount of entrained air, if present). The concrete shall be placed in a minimum of two layers approximately equal in depth and each not more than 100 mm thick.

Use the quantity of material in the final layer that, as nearly as possible, is just sufficient to fill the container without having to remove excess material. A small quantity of additional concrete may be added if necessary and further compacted in order to just fill the container, but the removal of excess material should be avoided.

### 6.3 Compaction of the concrete

Compact the concrete immediately after each layer is placed in the moulds in such a way as to produce full compaction of the concrete with neither excessive segregation nor laitance. Compact each layer by using one of the methods described in Annex D.

### 6.4 Surface levelling

If a filling frame is used, remove it immediately after compaction.

Remove the concrete above the upper edge of the mould using the two steel floats brought together with a sawing action or with a sawing action using a straight edge and level the surface carefully.

### 6.5 Marking

Identify the test specimens with a clear and durable marking, and without damaging the specimen.

Keep records to ensure that the specimen identity is known from sampling to testing.

## 7 Curing of test specimens

Leave the test specimens in the mould for at least 16 h, but not longer than three days, and protect against shock, vibration and water evaporation at a temperature of  $20^{\circ}\text{C} \pm 5^{\circ}\text{C}$  (or  $25^{\circ}\text{C} \pm 5^{\circ}\text{C}$  when the climate is hot).

After removal from the mould, store the test specimens in water at a temperature of  $20^{\circ}\text{C} \pm 2^{\circ}\text{C}$  or in a chamber at  $20^{\circ}\text{C} \pm 2^{\circ}\text{C}$  and a relative humidity of at least 95 % until just before testing.

Loss of moisture and deviations from the required curing temperature shall be avoided at all stages of transport. The test specimens should, therefore, be packed, for example, in wet sand or wet sawdust or wet cloths, or sealed in plastic bags containing water.

## 8 Measurement of dimensions and shape

### 8.1 Specimens made in calibrated moulds

If specimens have documentation to show that they were made in calibrated moulds, it is unnecessary to verify by measurement their conformity to the requirements for tolerances for flatness, perpendicularity, parallelism and straightness.

Specimens shall be checked to establish that each dimension is within 0,5 % of the designated size.

### 8.2 Specimens made in uncalibrated moulds

If specimens are not made in calibrated moulds, or there is no documentation to verify that they were made in calibrated moulds, the specimens shall be checked for conformity to the relevant requirements of Clause 4. The following shall be checked:

- a) each dimension of the specimen;
- b) the flatness of all the potential load-bearing surfaces;
- c) the parallelism of all the potential load-bearing surfaces;
- d) the perpendicularity of the sides;
- e) the straightness of any surface parallel to the centre line of the cylinder.

## 9 Report

9.1 The report shall include the following with regards to making the specimens:

- a) identification of the test sample;
- b) reason for making the specimens (e.g. compression testing), when known;
- c) time of making the specimen(s);
- d) temperature of the remixed concrete (optional);
- e) density of the concrete (optional);
- f) time passing between sampling and making the test specimens;
- g) method of compaction of the concrete in the mould(s);
- h) depending on the method of compaction, either the duration of compaction or the number of tamps;
- i) use of a filling frame (if appropriate);
- j) any deviation from the standard method of making specimen(s) (if appropriate).

## ISO 1920-3:2004(E)

**9.2** The report shall include the following with regards to curing the specimens:

- a) method of curing specimens prior to demoulding, including duration, curing conditions and temperature range;
- b) condition of specimens at receipt for storage (if appropriate);
- c) method of storing specimens after demoulding including transportation conditions (if appropriate), temperature range and duration of curing;
- d) any deviation from the standard method of making the specimen(s).

**9.3** The report shall include a declaration by the person technically responsible that the samples were prepared in accordance with this part of ISO 1920, except as noted in 9.1 j) or 9.2 d).

## Annex A (informative)

### Wet-sieving of concrete

#### A.1 General

Wet-sieving of concrete is the process of removing aggregate particles larger than a designated size from the fresh concrete by sieving on a sieve of the designated size.

This procedure is used when the nominal maximum size of the coarse aggregate in the concrete is larger than  $\frac{1}{4}$  of the basic dimension,  $l$  or  $d$ , of the test specimen, cube, cylinder and prism.

The effects of wet-sieving on the test results should be considered or determined by supplementary testing for quality control or test result evaluation purposes.

**EXAMPLE** Wet-sieving concrete causes the loss of a small amount of air due to additional handling. The air content of the wet-sieved fraction of concrete is greater than that of the total concrete because the larger size aggregate, which is removed, does not contain air. The apparent strength of wet-sieved concrete in smaller specimens is usually greater than that of the total concrete in larger appropriate size specimens.

#### A.2 Apparatus

##### A.2.1 Sieves.

**A.2.2 Wet-sieving equipment**, containing a sieve of the designated size conforming to the applicable specification and conveniently arranged and supported so that one can shake it rapidly by either hand or mechanical means.

Generally, a horizontal back-and-forth motion is preferred. The equipment shall be capable of rapidly and effectively removing particles larger than the designated size of aggregate.

**A.2.3** Hand tools, including the following:

**A.2.3.1** shovels;

**A.2.3.2** hand scoops;

**A.2.3.3** steel trowels;

**A.2.3.4** rubber gloves.

#### A.3 Procedure

After sampling the concrete and before remixing, sieve the concrete through a sieve of the designated size. Place only enough concrete on the sieve at any one time so that after sieving, the thickness of the layer of retained aggregate is not more than one particle thick. Shake or vibrate the sieve by hand or mechanical means until no undersize material remains on the sieve. Do not wipe off the mortar adhering to the aggregate retained on the sieve before it is discarded. Collect the concrete that passes through the sieve in a batch pan of suitable size that has been dampened before use, or on a clean, moist, non-absorbent surface. Scrape any mortar adhering to the sides of the wet-sieving equipment into the batch. Discard the aggregate particles retained on the sieve. Remix the concrete that has passed through the sieve with a shovel the minimum amount necessary to ensure uniformity and proceed immediately with testing.

## Annex B (informative)

### Application of ISO 1101 to concrete test specimens and moulds

#### B.1 General

ISO 1101 describes the geometric tolerancing. Figures B.1, B.2, B.3 and B.4 show particular applications of ISO 1101 to the measurement of concrete test specimens and moulds.

#### B.2 Flatness

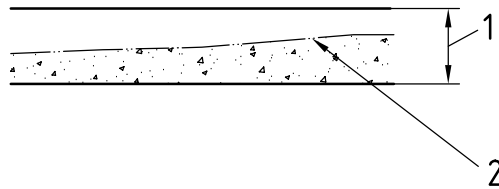

#### Key

- 1 flatness tolerance
- 2 surface to which flatness tolerance applies

Figure B.1 — Measurement of flatness

#### B.3 Parallelism

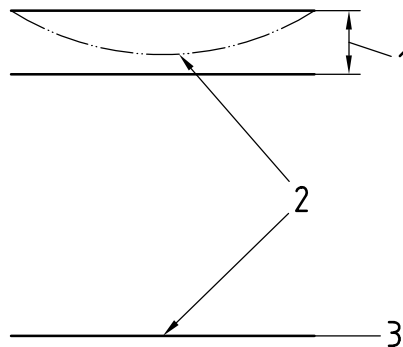

#### Key

- 1 perpendicular tolerance
- 2 surfaces to which the perpendicularity tolerance applies
- 3 bottom surface as datum surface

Figure B.2 — Measurement of parallelism

### B.4 Perpendicularity

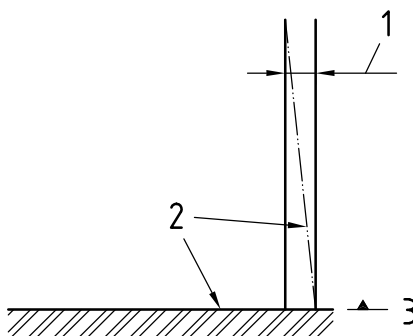

**Key**

- 1 perpendicular tolerance
- 2 surfaces to which the perpendicularity tolerance applies
- 3 adjacent surface as datum surface

**Figure B.3 — Measurement of perpendicularity**

### B.5 Straightness

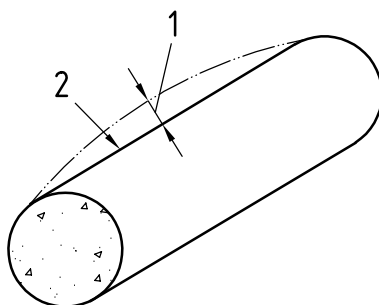

**Key**

- 1 straightness tolerance on the load-bearing surface
- 2 surface to which the straightness tolerance applies

**Figure B.4 — Measurement of straightness**

## Annex C (normative)

### Lightweight cylindrical moulds

#### C.1 General

This annex covers lightweight cylindrical moulds, both reusable and single-use for use in forming concrete specimens for strength tests (hereinafter referred to as moulds).

#### C.2 Dimensions, materials, quality and forming capability

##### C.2.1 Dimensions

Moulds shall be constructed in the form of cylinders with the top open to receive the concrete. They shall consist of a side-wall and bottom plate and conform to the requirements of Table C.1.

##### C.2.2 Materials

**C.2.2.1** Moulds shall be made of tin plate, paper, plastic or other materials that do not react chemically with Portland cement or other hydraulic cements contained in concrete.

**C.2.2.2** Moulds shall not corrode, deteriorate or be deformed while in use or in storage.

Moulds shall be coated, if necessary, to prevent adherence to concrete at the time of demoulding.

##### C.2.3 Quality

**C.2.3.1** Moulds shall be watertight and shall not deform while forming concrete specimens. They shall conform to the requirements of Table C.1 when tested in accordance with Clause C.3 of this annex.

**C.2.3.2** Reusable moulds shall be capable of retaining the qualities specified in Table C.1 when used repeatedly.

**Table C.1 — Dimensions and quality requirements for moulds**

Item	Requirements
dimensions and tolerances on dimensions and shape	in accordance with 4.3
leakage	no visual leakage 1 h after filling with water and 1 h after filling with concrete
absorption and elongation <sup>a</sup>	absorption:    100 mm diameter by 200 mm long: $\leq 1,0$ g 125 mm diameter by 250 mm long: $\leq 1,6$ g 150 mm diameter by 300 mm long: $\leq 2,3$ g  elongation: $\leq 0,20$ %
<sup>a</sup> These requirements shall apply only to paper moulds.	



## C.2.4 Forming capability

Moulds shall be capable of forming cylindrical concrete specimens using the procedures given in Clause 6. In the case where moulds can be deformed by tapping directly with a mallet, maintain the mould in a holder and tap the side-wall of the holder. The holder may be of steel or plastic, accommodating one to three moulds. The holder shall be sufficiently stiff so that the moulds do not deform when the holder is tapped on the side-wall with a mallet during concrete placing.

When demoulding, moulds shall allow the specimens to be removed easily without any damage.

## C.3 Tests

### C.3.1 Dimensions

Measure, with callipers, the inside diameters at right angles to each other and inside heights opposite to each other of three randomly selected moulds. Calculate the averages of the two measurements as the inside diameter and inside height of each mould. The maximum (or minimum) difference between the nominal and measured values shall be taken as the dimensional variance.

### C.3.2 Leakage

**C.3.2.1** During the absorptivity and elongation tests described in C.3.4, examine for visual leakage from the moulds 1 h after the beginning of the tests.

**C.3.2.2** During forming concrete specimens in accordance with C.3.3.1, examine for visual leakage from the moulds 1 h after the placement.

### C.3.3 Flatness of bottom plate and perpendicularity of side wall

#### C.3.3.1 Concrete specimens

Three concrete specimens shall be formed using randomly selected lightweight moulds, and the flatness and perpendicularity of the specimens shall be measured.

#### C.3.3.2 Flatness

Two lines both passing the centre of the bottom of a specimen and at right angles to each other shall be taken as traverse lines, and the flatness shall be measured with regard to both ends and the centres of the lines. Measure the distances between each measuring point with a dial gauge (which shall be graduated to 0,001 mm), determine the departure of the centre point from the straight line between both ends of each traverse line, and calculate their average as the flatness of each specimen (see Figure C.1). The maximum value of three specimens shall be taken as the flatness of the mould.

#### C.3.3.3 Perpendicularity

The perpendicularity shall be measured as follows: Place a dial gauge stand on a horizontal base and fix the dial gauge at a position corresponding to the height,  $h$ , of a specimen. Calculate the difference between the dial gauge reading when a square is placed and when a specimen is placed at the same position (see Figure C.2).

Measurements shall be made in two directions at right angles to each other, and their average shall be taken as the perpendicularity of the specimen. The maximum value of three specimens shall be taken as the perpendicularity of the mould.

### C.3.4 Absorption and elongation

The tests shall be conducted on three randomly selected moulds.

Measure the mass,  $m_0$ , of a mould before testing in a thermostatic chamber at 20 °C using a balance capable of measuring to an accuracy of 0,1 g. Place the mould on a flat surface and fill with water at 20 °C to a depth of approximately 95 % of the nominal mould height. Immediately cover the mould with a glass plate, place on the dial stand and set the dial gauge so that the axial elongation can be measured on the mould axis at the top of the glass plate. Record the dial gauge reading immediately after filling with water,  $h_0$ , (see Figure C.3).

Allow the mould to stand for 3 h and record the reading of the dial gauge again,  $h_1$ . Empty water from the mould, wipe quickly with a dry towel and record the mass,  $m_1$ , of the mould after testing. Calculate the absorption in accordance with Equation (C.1) to the nearest 0,1 g and the elongation in accordance with Equation (C.2) to the nearest 0,1 %.

$$\text{Absorption} = m_1 - m_0 \quad (\text{C.1})$$

where

$m_0$  is the mass of mould before testing, expressed in grams;

$m_1$  is the mass of mould after testing, expressed in grams.

$$\text{Elongation} = \frac{h_1 - h_0}{h} \times 100 \quad (\text{C.2})$$

where

$h$  is the nominal height, expressed in millimetres, of the mould;

$h_0$  is the dial gauge reading, expressed in millimetres, immediately after filling with water;

$h_1$  is the dial gauge reading, expressed in millimetres, 3 h after filling with water.

### C.4 Labeling

The following shall be labelled on the container or invoice:

- a) designation (brand);
- b) product dimensions;
- c) amount;
- d) date produced;
- e) name of manufacturer;
- f) production number;
- g) maximum number of reuses;
- h) cautions.

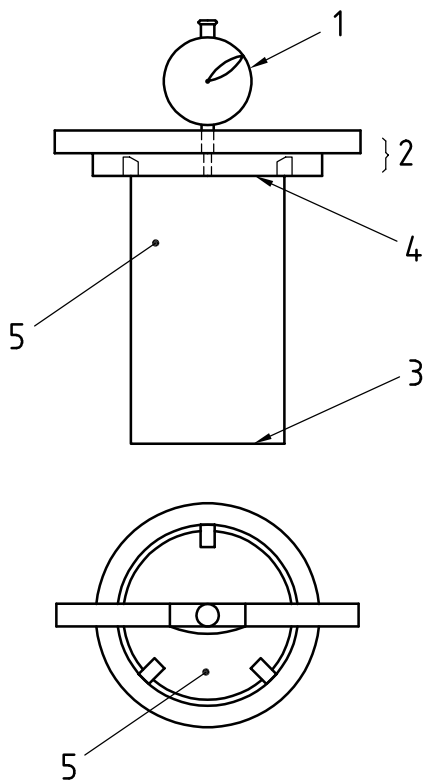

**Key**

- 1 dial gauge, graduated to 0,001 mm
- 2 device for measuring flatness
- 3 top surface (placing surface)
- 4 bottom
- 5 specimen

**Figure C.1 — Device for measuring bottom flatness of specimens**

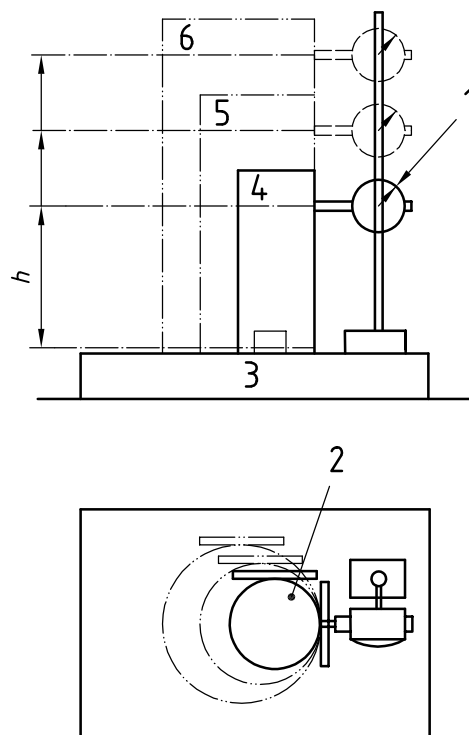

**Key**

- 1 dial gauge, graduated to 0,001 mm
- 2 specimen
- 3 surface plate
- 4 sample with diameter of 100 mm and height of 200 mm
- 5 sample with diameter of 125 mm and height of 250 mm
- 6 sample with diameter of 150 mm and height of 300 mm

**Figure C.2 — Device for measuring perpendicularity of bottom to side-wall of specimens**

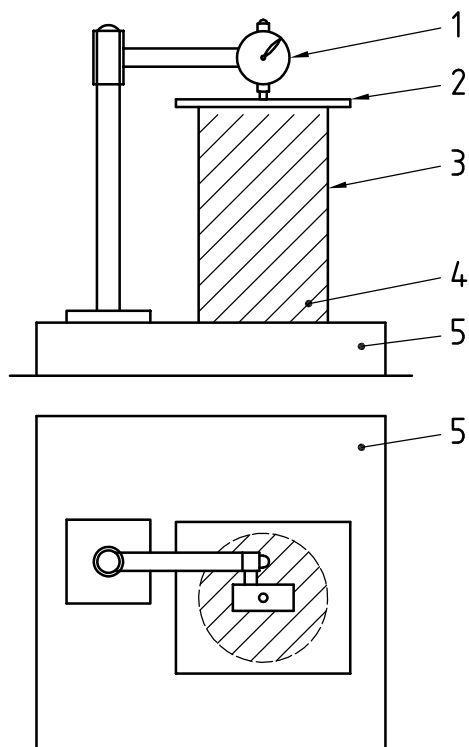

**Key**

- 1 dial gauge, graduated to 0,001 mm
- 2 glass plate
- 3 mold
- 4 water
- 5 horizontal base

**Figure C.3 — Device for measuring absorptivity and elongation**

## Annex D (normative)

### Methods of compaction

#### D.1 General

The methods of compaction are described in D.2, D.3, D.4 and D.5.

#### D.2 Compacting with an internal vibrator

Apply the vibration for the minimum duration necessary to achieve full compaction of the concrete. Avoid over-vibration, which may cause excessive segregation and laitance or loss of air, if present. Take care not to damage the container. The duration of vibration shall be recorded to the nearest 1 s.

#### D.3 Compacting with a vibrating table

Apply the vibration for the minimum duration necessary to achieve full compaction of the concrete. When using a vibrating table the mould shall be attached or firmly held against the table.

**WARNING — It should not be held by hand; see the caution at the beginning of this part of ISO 1920.**

Avoid over-vibration, which may cause excessive segregation and laitance or loss of entrained air, if present. The required duration of vibration will depend upon the consistency of the concrete and the effectiveness of the vibrating table and vibration shall cease as soon as the surface of the concrete becomes relatively smooth and has a glazed appearance. The duration of the vibration shall be recorded to the nearest 1 s.

#### D.4 Compacting with a compacting rod

Distribute the strokes of the compacting rod in a uniform manner over the cross-section of the mould. Ensure that the compacting rod does not penetrate significantly any previous layer nor forcibly strike the bottom of the mould when compacting the first layer. When compacting cubes and prisms having a designated size,  $l$ , of 150 mm, and cylinders having a designated diameter,  $d$ , of 150 mm, subject the concrete to 25 strokes or tamps per layer. When compacting specimens of other dimensions or concrete of high consistence, the number of strokes or tamps per layer shall be as appropriate.

NOTE When compacting high-consistency concrete, full compaction might be achieved with fewer strokes.

In order to remove pockets of entrapped air but not the entrained air, after compaction of each layer, tap the sides of the mould smartly with the mallet until large bubbles of air cease to appear on the surface and depressions left by the compacting rod are removed. The number of strokes of the rod shall be recorded.

#### D.5 Compacting with a compacting bar

The concrete shall be compacted in accordance with D.4.

## Annex E (informative)

### Example of specimen preparation test report

**Client**

**Test organization**

Accreditation test report ref.

**Test Location**

---

**Sample**

Sample number:                      Date and time of sampling:

Condition of sample:              on receipt:  
    at time of test:  
    abnormalities:  
    temperature: (if required)

---

**Details of specimen(s) preparation**

Mould numbers                      .....                      .....                      .....                      .....                      .....

Checked for:						
cleanliness and	Yes/No	Yes/No	Yes/No	Yes/No	Yes/No	Yes/No
release agent:						

Location of specimen preparation:                      Environmental conditions:

Method of compaction:

Vibrating Table	reference:	Internal vibrator	reference:	time:
Compacting rod	reference:	Compacting bar	reference:	tamps:

Filling frame used              Yes/No              Time at completion of sample preparation:

Any deviations from ISO 1920-3:

Except as detailed above, the specimens were prepared in accordance with ISO 1920-3:2004.

---

**Technical Responsibility**

Responsible person:    Name:    Position:

Signature:

---

**Test report identification**

Test report No:                      Date issued:

## Bibliography

- [1] ISO 1920-2, *Testing of concrete — Part 2: Properties of fresh concrete*





© ISO 2004. All rights reserved.

---

---

**ICS 91.100.30**

Price based on 20 pages