

---

---

**Testing of concrete —**  
**Part 12:**  
**Determination of the carbonation**  
**resistance of concrete — Accelerated**  
**carbonation method**

*Essais du béton —*

*Partie 12: Détermination de la résistance du béton à la carbonation*  
*— Méthode de carbonation accélérée*



Reference number  
ISO 1920-12:2015(E)

© ISO 2015



**COPYRIGHT PROTECTED DOCUMENT**

© ISO 2015, Published in Switzerland

All rights reserved. Unless otherwise specified, no part of this publication may be reproduced or utilized otherwise in any form or by any means, electronic or mechanical, including photocopying, or posting on the internet or an intranet, without prior written permission. Permission can be requested from either ISO at the address below or ISO's member body in the country of the requester.

ISO copyright office  
Ch. de Blandonnet 8 • CP 401  
CH-1214 Vernier, Geneva, Switzerland  
Tel. +41 22 749 01 11  
Fax +41 22 749 09 47  
copyright@iso.org  
www.iso.org

# Contents

	Page
<b>Foreword</b> .....	<b>iv</b>
<b>Introduction</b> .....	<b>v</b>
<b>1 Scope</b> .....	<b>1</b>
<b>2 Normative references</b> .....	<b>1</b>
<b>3 Terms and definitions</b> .....	<b>1</b>
<b>4 Principle</b> .....	<b>2</b>
<b>5 Reagents and apparatus</b> .....	<b>2</b>
<b>6 Preparation of specimens</b> .....	<b>3</b>
6.1 General .....	3
6.2 Making, curing, and testing of prisms and cubes .....	3
<b>7 Carbonation depth measurements</b> .....	<b>5</b>
7.1 Exposure period and generation of colour change .....	5
<b>8 Determination of the carbonation depth</b> .....	<b>5</b>
8.1 General .....	5
8.2 Measuring the depth of carbonation .....	5
8.3 Appreciation of dense aggregates .....	5
8.4 Appreciation of pores and porous aggregates and extreme values .....	6
8.5 Expression of the results .....	7
<b>9 Test report</b> .....	<b>7</b>
<b>10 Precision</b> .....	<b>7</b>
<b>Annex A (informative) Guidance on suitable storage chambers</b> .....	<b>8</b>

## Foreword

ISO (the International Organization for Standardization) is a worldwide federation of national standards bodies (ISO member bodies). The work of preparing International Standards is normally carried out through ISO technical committees. Each member body interested in a subject for which a technical committee has been established has the right to be represented on that committee. International organizations, governmental and non-governmental, in liaison with ISO, also take part in the work. ISO collaborates closely with the International Electrotechnical Commission (IEC) on all matters of electrotechnical standardization.

The procedures used to develop this document and those intended for its further maintenance are described in the ISO/IEC Directives, Part 1. In particular the different approval criteria needed for the different types of ISO documents should be noted. This document was drafted in accordance with the editorial rules of the ISO/IEC Directives, Part 2 (see [www.iso.org/directives](http://www.iso.org/directives)).

Attention is drawn to the possibility that some of the elements of this document may be the subject of patent rights. ISO shall not be held responsible for identifying any or all such patent rights. Details of any patent rights identified during the development of the document will be in the Introduction and/or on the ISO list of patent declarations received (see [www.iso.org/patents](http://www.iso.org/patents)).

Any trade name used in this document is information given for the convenience of users and does not constitute an endorsement.

For an explanation on the meaning of ISO specific terms and expressions related to conformity assessment, as well as information about ISO's adherence to the WTO principles in the Technical Barriers to Trade (TBT) see the following URL: [Foreword - Supplementary information](#)

The committee responsible for this document is ISO/TC 71, *Concrete, reinforced concrete and pre-stressed concrete*, Subcommittee SC 1, *Test methods for concrete*.

ISO 1920 consists of the following parts, under the general title *Testing of concrete*:

- *Part 1: Sampling of fresh concrete*
- *Part 2: Properties of fresh concrete*
- *Part 3: Making and curing test specimens*
- *Part 4: Strength of hardened concrete*
- *Part 5: Properties of hardened concrete other than strength*
- *Part 6: Sampling, preparing and testing of concrete cores*
- *Part 7: Non-destructive tests on hardened concrete*
- *Part 8: Determination of drying shrinkage of concrete for samples prepared in the field or in the laboratory*
- *Part 9: Determination of creep of concrete cylinders in compression*
- *Part 10: Determination of static modulus of elasticity in compression*
- *Part 11: Determination of the chloride resistance of concrete, unidirectional diffusion*
- *Part 12: Determination of the carbonation resistance of concrete — Accelerated carbonation method*

## Introduction

Ferrous steel reinforced concrete structures need to be durable to ensure that the intended service life is achieved. The corrosion of reinforcement induced by carbonation can play a significant role in the serviceability of a structure and consequently carbonation resistance of concrete is an important property to measure. This International Standard sets out a test method that may be applied to cast test specimens to assess the potential carbonation resistance properties of a concrete mix.



# Testing of concrete —

## Part 12:

# Determination of the carbonation resistance of concrete — Accelerated carbonation method

## 1 Scope

This procedure is a method for evaluating the carbonation resistance of concrete using an accelerated carbonation test. After a period of preconditioning, the test is carried out under controlled exposure conditions using an increased level of carbon dioxide to which, the vertical sides of the specimen are exposed.

The test results are not designated to set performance requirements but to compare the carbonation resistance of different concretes of the same strength class, which are used in the same environmental conditions.

## 2 Normative references

The following documents, in whole or in part, are normatively referenced in this document and are indispensable for its application. For dated references, only the edition cited applies. For undated references, the latest edition of the referenced document (including any amendments) applies.

ISO 1920-2, *Testing of concrete — Part 2: Properties of fresh concrete*

ISO 1920-3, *Testing of concrete — Part 3: Making and curing test specimens*

ISO 1920-4, *Testing of concrete — Part 4: Strength of hardened concrete*

## 3 Terms and definitions

For the purposes of this document, the following terms and definitions apply.

### 3.1

#### **depth of carbonation**

depth as measured using a phenolphthalein solution sprayed on a freshly-split concrete surface

### 3.2

#### **single point carbonation depth**

depth of carbonation measured at a single point on a specimen,  $d_{k,\text{point}}$

### 3.3

#### **specimen face carbonation depth**

mean depth of carbonation of a single exposed face of a single specimen,  $d_{k,\text{face}}$

### 3.4

#### **specimen carbonation depth**

mean depth of carbonation of a single specimen,  $d_{k,\text{spec}}$

### 3.5

#### **mean carbonation depth**

mean depth of carbonation of two specimens,  $d_k$

## 4 Principle

Two concrete cubes are cast and cured for 28 d in accordance with ISO 1920-3 (see also changes to the curing conditions in 6.2). The two concrete cubes are then conditioned in a laboratory air environment for 14 d prior to sealing the top, bottom, and two opposite side faces. After sealing of all but two faces, the cubes are placed in a storage chamber meeting the conditions specified in 5.4 and having a carbon dioxide level of  $(3,0 \pm 0,5) \%$  for a period of 70 d. After 70 d of exposure, the cubes shall be split in half, perpendicular to the exposed faces, and the depth of carbonation measured in accordance with the procedure given in Clause 7.

The test under reference conditions takes therefore a minimum of 112 d, period that comprises a minimum age of the specimen of 28 d prior to conditioning, a minimum conditioning period of 14 d, and a minimum exposure to increased carbon dioxide levels of 70 d. In case where a higher range of additions such as pozzolanic materials, slag, and others are used, extended curing and drying times are allowed and the same should be reported.

If required, further cubic specimens may be casted and used for measurement of the depth of carbonation at exposure periods other than 70 d. Each cubic specimens shall be used for testing at one period of exposure only.

When the purpose of the test is to measure the depth of carbonation on the same specimen at more than one exposure period, concrete prisms shall be used.

In this case, two prisms are cast and cured for 28 d in accordance with ISO 1920-3 (see also amendments of the curing conditions in 6.2). The prisms are conditioned in a laboratory air environment for 14 d prior to sealing the top, bottom, and two end faces. After sealing all but two longitudinal faces, the prisms are placed in a storage chamber, meeting the conditions specified in 5.4 and having a carbon dioxide level of  $(3,0 \pm 0,5) \%$  for the overall test period which should be 70 d. After each exposure period, a 50 mm slice is broken from each prism and tested for carbonation depth. After splitting off a slice, the split end faces of the prisms are sealed and the remainder of the prisms returned to the storage chamber.

The specimens, cubes, or prisms shall be positioned with their exposed faces in the vertical position.

The curing conditions may vary from one country to another in accordance with local provisions; however, these conditions shall be recorded and reported.

## 5 Reagents and apparatus

**5.1 Paraffin wax or equivalent**, for sealing the non-exposed faces of test specimens.

**5.2 A solution**, made of 1 g of phenolphthalein powder dissolved in 100 ml solution composed of 70 ml ethanol and 30 ml of deionised water.

**5.3 A magnifier and a gauge**, to measure the depth of carbonation perpendicular to the exposed concrete surface with a precision of 0,5 mm.

**5.4 A storage chamber with a carbon dioxide concentration at  $(3,0 \pm 0,5) \%$  by volume, temperature at  $(22 \pm 2) ^\circ\text{C}$ , and a relative humidity at  $(55 \pm 5) \%$** , see Annex A for details of a suitable chamber. In hot climate locations, the conditions in the storage chamber may be temperature at  $(27 \pm 2) ^\circ\text{C}$  and relative humidity at  $(65 \pm 5) \%$ .

Experience has shown that if saturated surface-dry specimens are placed in the storage chamber shortly after removal from water curing, the relative humidity could exceed that permitted. Also, in storage chambers without active control of the carbon dioxide, the levels could drop below the permitted tolerance as the carbonation process continues. It is therefore a recommendation of this test method that the storage chamber has active control on carbon dioxide, relative humidity, and temperature.



Other carbon dioxide concentration levels, other humidity levels, and other temperature levels may be used. However, this shall be recorded and reported.

**NOTE** Relative humidity levels may be maintained using methods at the discretion of the laboratory, for example, active humidification/dehumidification or saturated salt solutions.

**5.5 Apparatus**, for recording the relative humidity with a precision of  $\pm 2,0$  % and the temperature with a precision of  $\pm 0,5$  °C.

**5.6 Apparatus**, for recording CO<sub>2</sub> concentration with a precision of  $\pm 0,1$  % by volume.

It is recommended that recording apparatus be fitted with an audio/visual alarm to alert breaches of CO<sub>2</sub> concentration within the storage chamber due to possible apparatus malfunction.

**5.7 Fans**, to facilitate steady circulation of air within the storage chamber.

## 6 Preparation of specimens

### 6.1 General

Cubes and/or prisms for the determination of the carbonation resistance shall be made in accordance with this part of ISO 1920. If the specimens are to be made by a test laboratory, the test laboratory shall be supplied with a full specification including the mix quantities and the mixing procedure, and where appropriate, the constituent materials. Where the specimens are prepared by the client or their representative, the test laboratory shall be informed of the day of casting and provided with a confirmation that the specimens were stored as required by this part of ISO 1920.

For the determination of the depth of carbonation at any given exposure period, two cubic specimens having a cross-section of 100 mm or greater shall be prepared. For the determination of the depth of carbonation at more than one exposure period on the same test specimen, two prisms, 400 mm long and having a cross-section of 100 × 100 mm, shall be prepared. The shortest dimension of the specimen, cube, or prism, shall not be less than four times the maximum nominal upper aggregate size. The use of mould release agents should be avoided or minimized, as they might influence the carbonation depth.

### 6.2 Making, curing, and testing of prisms and cubes

Before casting the specimens, measure the consistence class or target value using the slump test, Vebe test, degree of compactability, or flow table test (as appropriate), as described in ISO 1920-2. For each mix, cast two prisms/cubes from a single batch of concrete. Cast the prisms horizontally according to ISO 1920-3. In hot climate locations, the curing conditions after demoulding the specimen can be different from those mentioned in ISO 1920-3. In this case, the specimens shall be stored in water or in a chamber having a temperature in the range of  $(27 \pm 2)$  °C and a minimum relative humidity of 95 %. After finishing the prisms/cubes, cover the exposed surface with polythene or similar impermeable sheeting to prevent drying. After  $(22 \pm 2)$  h, the moulds shall be stripped and the prisms/cubes transferred without delay into a water-filled bath with temperature control set in the range of  $(20 \pm 2)$  °C in accordance with ISO 1920-3. In hot climate locations, the temperature of the water in the bath may be in the range of  $(27 \pm 2)$  °C.

It is recommended that at least two compressive strength specimens are made and tested in accordance with ISO 1920-4 at 28 d. Where a number of mixes are made, additional testing, e.g. the 28-day strength, should be undertaken to confirm consistent manufacture or identify anomalous batches where mixes might need to be repeated.

After removal from the curing tank, the specimens shall be immediately wrapped and sealed in polythene or similar material that will prevent drying during transportation. Alternatively, they should be transported while remaining fully immersed in water, e.g. in a mobile curing tank. On arrival at the test laboratory, the test specimens shall be unwrapped, checked for damage, and then stored in a water-filled

## ISO 1920-12:2015(E)

curing tank with temperature in the range of  $(20 \pm 2) ^\circ\text{C}$  in accordance with ISO 1920-3 until they are 28 d old. In hot climate locations, the temperature of the water in the bath may be in the range of  $(27 \pm 2) ^\circ\text{C}$ .

At an age of 28 d, the prisms/cubes shall be removed from the water bath and transferred for 14 d to a laboratory air drying environment having a temperature in the range of  $(18 - 29) ^\circ\text{C}$  and relative humidity in the range of  $(50 - 70) \%$ .

Alternative conditioning environments may be used; however, they shall be recorded and reported.

After 14 d of conditioning, the top and bottom longitudinal faces and the two end faces of prisms (or top, bottom, and two side faces of cubes) shall be sealed using paraffin wax or a similar material that will prevent ingress of carbon dioxide and allow carbonation to occur only on two cast longitudinal surfaces. See [Figure 1 a](#)).

NOTE 1 The purpose of sealing the top, bottom, and end faces is to minimize any corner effect from multi-directional carbonation and also to prevent longitudinal carbonation through the prism/cube.

NOTE 2 If paraffin wax is used to seal the surfaces, melt it in a temperature controlled crucible and apply to the concrete surface with a paint brush in three equal layers, leaving the wax to set on the concrete between each application.

Once the prisms/cubes have been sealed, they shall be placed in the storage chamber complying with [5.4](#). The prisms/cubes shall be positioned in such a way that their exposed faces are vertical and that permits air to circulate freely around the two faces that are to be carbonated (see [Annex A](#)).

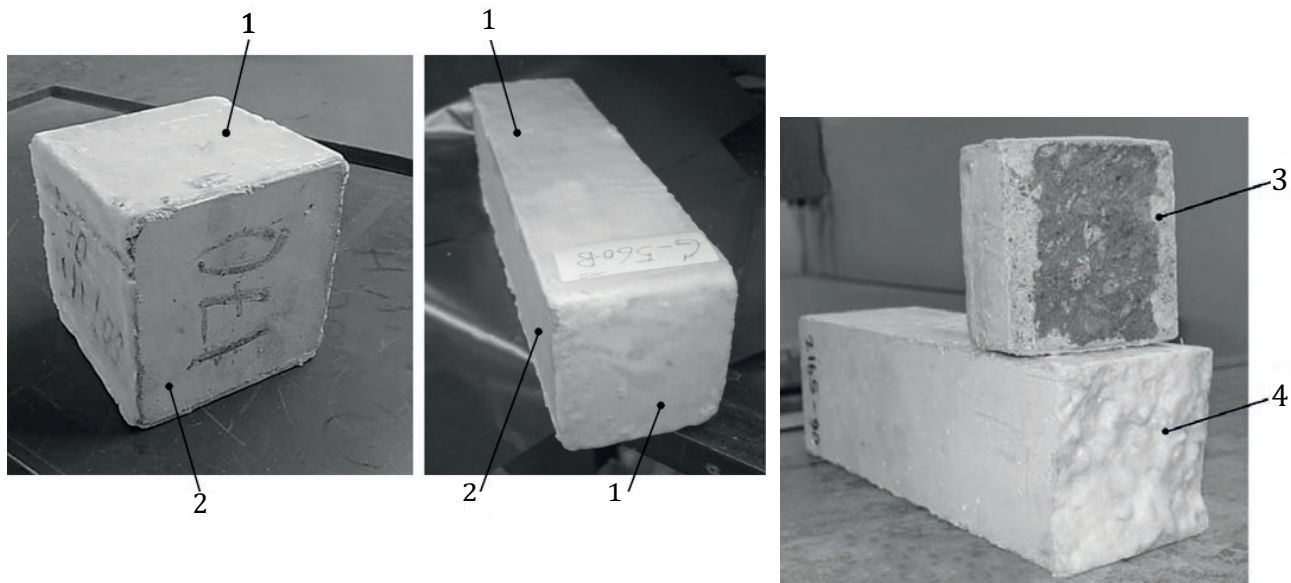

a) Sealing cube and prism prior to placing in storage environment for the first time

b) Sealing of split end face of prism after removing slice for testing carbonation depth

### Key

- 1 waxed faces
- 2 exposed faces

- 3 concrete slice split and sprayed with phenolphthalein
- 4 prism split and resealed

**Figure 1 — Sealing of prism specimen prior to and during testing**

## 7 Carbonation depth measurements

### 7.1 Exposure period and generation of colour change

The carbonation depth of prisms shall be measured after the following exposure periods: 56 d, 63 d, and 70 d or as specified after placing in the storage chamber. The carbonation depth of cubes shall be measured at 70 d unless specified otherwise.

10 single point carbonation depths ( $d_{k,point}$ ) are measured after each exposure period on each prism or cube and the depth of carbonation  $d_k$  is expressed as the mean of the 20 readings.

A slice approximately 50 mm thick shall be broken off after each exposure period and the split surface on the remaining prism resealed to prevent longitudinal carbonation [see [Figure 1 b](#)]. Where a single determination of the carbonation depth is made on a cube after 70 d of storage, the cube shall be split in half. The depths of carbonation on the freshly broken surface of the split slice shall be measured.

NOTE 1 Slicing by saw is not suitable.

Clear the broken surface immediately of dust and loose particles after breaking and then spray with a fine mist of indicator solution. Avoid the formation of flow channels on the test surface. If only a weak colouration or none at all appears on the treated surface, spray again after 30 s.

The measurements shall be conducted after the colour has stabilized.

NOTE 2 The measured depth of carbonation may be influenced by the time of measuring after application of the indicator solution.

## 8 Determination of the carbonation depth

### 8.1 General

The carbonation depth shall be determined by the colour change in accordance with the method given below.

### 8.2 Measuring the depth of carbonation

The carbonation depth shall be measured at five points on each exposed face. To locate these points, the edge length shall be divided into six equal distances. The five central points shall be used. With the help of a ruler or a sliding gauge and a magnifier, the point carbonation depth ( $d_{k,point}$ ) shall be determined perpendicular to the exposed surface of the prism with a precision of 0,5 mm per measured point.

The depth of the carbonation shall be measured on the one broken face on both prisms giving (normally) a total of at least 20 measurement points.

### 8.3 Appreciation of dense aggregates

Dense aggregate particles that lie within the carbonation front will not be coloured by the phenolphthalein and the carbonation front will be interrupted by the particle [see [Figure 2 a](#)]. For determining the

carbonation depth, the theoretical carbonation depth at the intersection of the location point and a line connecting the limits on each side of the particle [see Figure 2 b)] shall be used.



a) Dense aggregate interrupting carbonation front

b) Theoretical carbonation front drawn across dense aggregate

**Key**

- 1 measuring points
- 2 dense aggregate
- 3 theoretical carbonation front

**Figure 2 — Procedure for obtaining the carbonation depth where the point falls within a dense aggregate particle**

**8.4 Appreciation of pores and porous aggregates and extreme values**

When there are pores or particles of porous aggregates lying in the area of the carbonation front, extreme values of the carbonation depth may appear (see Figure 3). Where the measured values of  $\Delta d_{k,point}$  are less than 4 mm, they shall be used in the calculation of the mean carbonation depth. Higher values of  $\Delta d_{k,point}$  shall not be included when calculating the mean carbonation depth; however, the existence of high values of  $\Delta d_{k,point}$  shall be recorded in the test report.

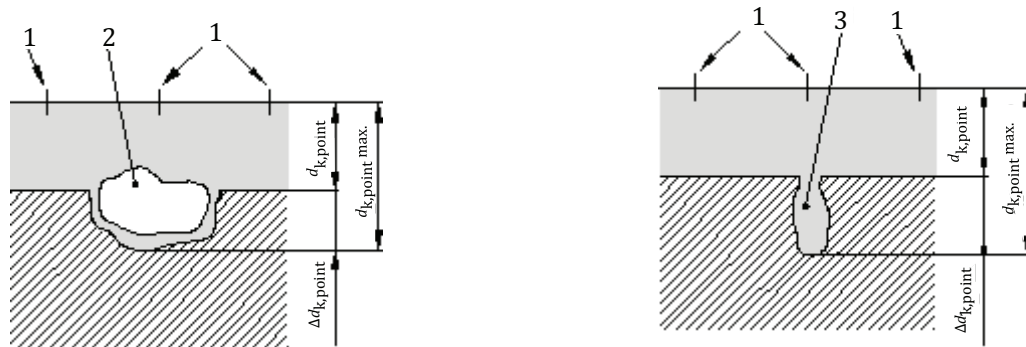

a) Porous aggregate interrupting carbonation front

b) Air void interrupting carbonation front

**Key**

- 1 measuring points
- 2 porous aggregate
- 3 air void

**Figure 3 — Procedure for obtaining the carbonation depth where the point falls on a porous aggregate particle or on air void**

## 8.5 Expression of the results

The mean depth of carbonation for each exposed face of a specimen ( $d_{k, \text{face}}$ ) shall be calculated and recorded. The mean depth of carbonation for each specimen ( $d_{k, \text{spec}}$ ) shall be calculated and recorded. The arithmetical mean of the mean carbonation depth of two specimens ( $d_k$ ) at 70 d shall be reported as the carbonation depth of the concrete mix.

Where testing is undertaken on prisms at alternative exposure periods, these shall be expressed as the arithmetical mean of two specimens ( $d_k$ ) at the reported alternative exposure periods.

## 9 Test report

- a) reference of the concrete under test;
- b) date of casting of the specimens;
- c) date of the start of the test;
- d) all measured minimum and maximum carbonation depths of at least 20 points at the reference exposure period of 70 d or the specified exposure periods;
- e) mean carbonation depth of specimen faces ( $d_{k, \text{face}}$ ), each specimen ( $d_{k, \text{spec}}$ ), and the overall mean ( $d_k$ );
- f) if any, the number of values of  $\Delta d_{k, \text{point}}$  and their magnitude that were not included in the calculation of the mean value;
- g) any deliberate deviation from the reference conditions or non-conformity with the test conditions, e.g. any failure to maintain the required carbon dioxide for an identified short period or changes to the preconditioning environment.

The test report may contain the following:

- a) details of the concrete mixes;
- b) individual test results and relevant photographic records;
- c) results of additional testing, e.g. compressive strength results at 28 d;
- d) any additional comments or observations;
- e) any accreditation for undertaking the test procedure.

## 10 Precision

The repeatability ( $r$ ) of the carbonation measurements (95 % confidence level) is  $r = 2,0$  mm with a repeatability standard deviation of 1,0 mm. No repeatability or reproducibility data are available for the full test.

## Annex A (informative)

### Guidance on suitable storage chambers

The features of a typical storage chamber are given in [Figure A.1](#). For the reference conditions, the carbon dioxide content of the air within the storage chamber is required to be  $(3,0 \pm 0,5)$  % by volume. When a large number of specimens are placed in a chamber, the carbon dioxide content might fall rapidly and remain below the required levels. For this reason, it is recommended that the carbon dioxide content be controlled and a suitable method is by means of a carbon dioxide injector connected to the chamber to replace carbon dioxide consumed by the carbonation reaction. A suitable apparatus is shown in [Figure A.2](#) and [Figure A.3](#). Monitoring of the readings from the carbon dioxide injection equipment should be carried out on a daily basis. Any deviations from this level should be reported.

Prisms should be stored either horizontally or vertically. Where prisms are stored horizontally, they should be positioned in such a way to permit the free flow of air to the exposed, unsealed faces of the prism, e.g. using spacers cut from 50 mm diameter plastic piping. It is recommended that spacers should be placed on the sealed faces of the specimens. Prisms should be placed in the storage chamber in a manner that ensures a gap of at least 50 mm between prisms; see [Figure A.4](#). A similar gap should be provided between the prisms and the walls.

Mechanical fans (table fans are suitable) should be positioned within the storage chamber to ensure air circulation. It is recommended that the turbulence be monitored during commissioning of the chamber by means of a smoke generator test or a similar method. The storage chamber should be tested with both the minimum and maximum number of prisms to be used to ensure adequate air circulation during use.

Experience has shown that if non-standard saturated surface-dry specimens are placed in the storage chamber, the relative humidity could exceed that permitted. It is therefore a recommendation that the storage chamber has active control on relative humidity (50 – 70) % and temperature (18 – 29) °C.



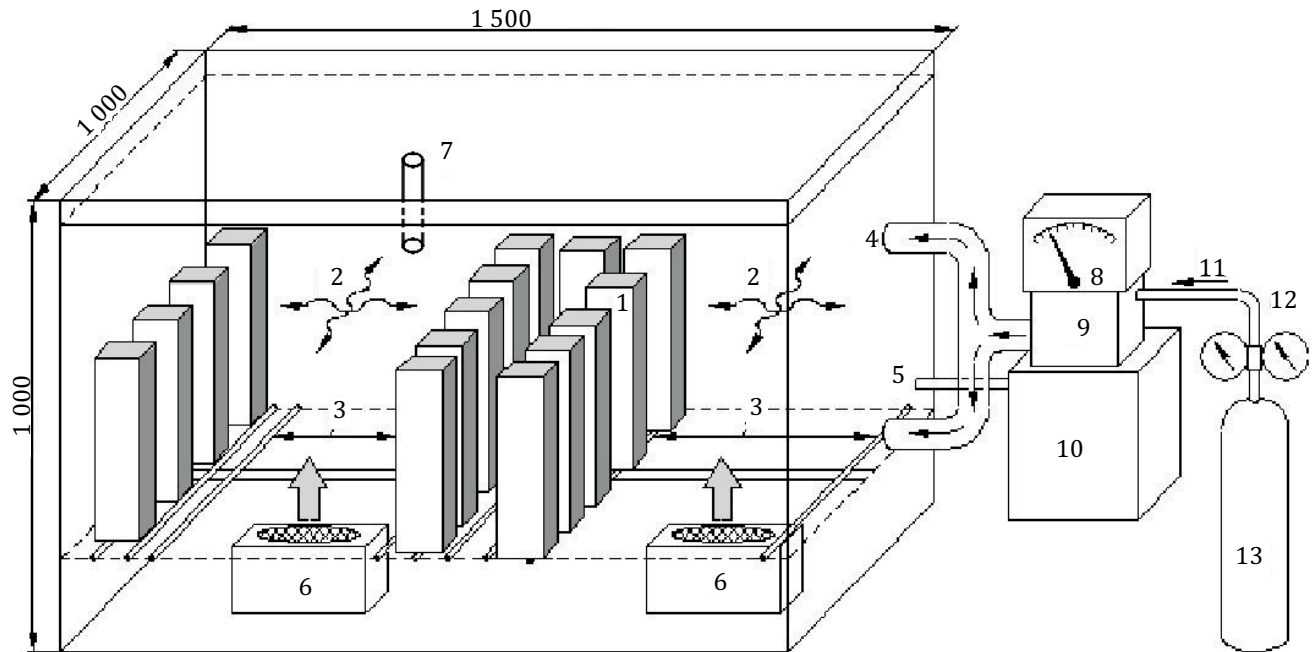

### Key

- 1 concrete specimens
- 2 turbulent flow
- 3 wooden platform
- 4 CO<sub>2</sub> inlet
- 5 steam inlet
- 6 fan
- 7 temperature control device
- 8 CO<sub>2</sub> controller
- 9 control box
- 10 dehumidifier
- 11 gas input
- 12 regulator
- 13 CO<sub>2</sub> gas cylinder

**Figure A.1 — Typical storage chamber with vertical storage**

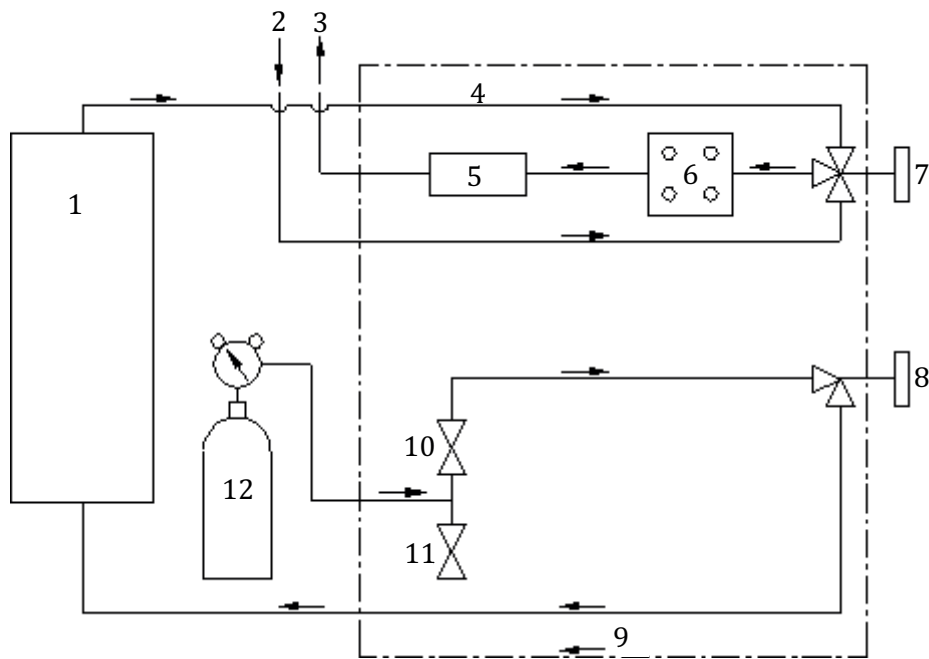

**Key**

- 1 carbonation storage chamber
- 2 zero air in
- 3 sample out
- 4 sample in
- 5 pump
- 6 thermal conductivity detector
- 7 selector valve
- 8 fine metering valve
- 9 CO<sub>2</sub> controller
- 10 CO<sub>2</sub> controller valve hi
- 11 CO<sub>2</sub> controller valve lo
- 12 CO<sub>2</sub> cylinder

**Figure A.2 — Suitable system for carbonation dioxide injection and monitoring**



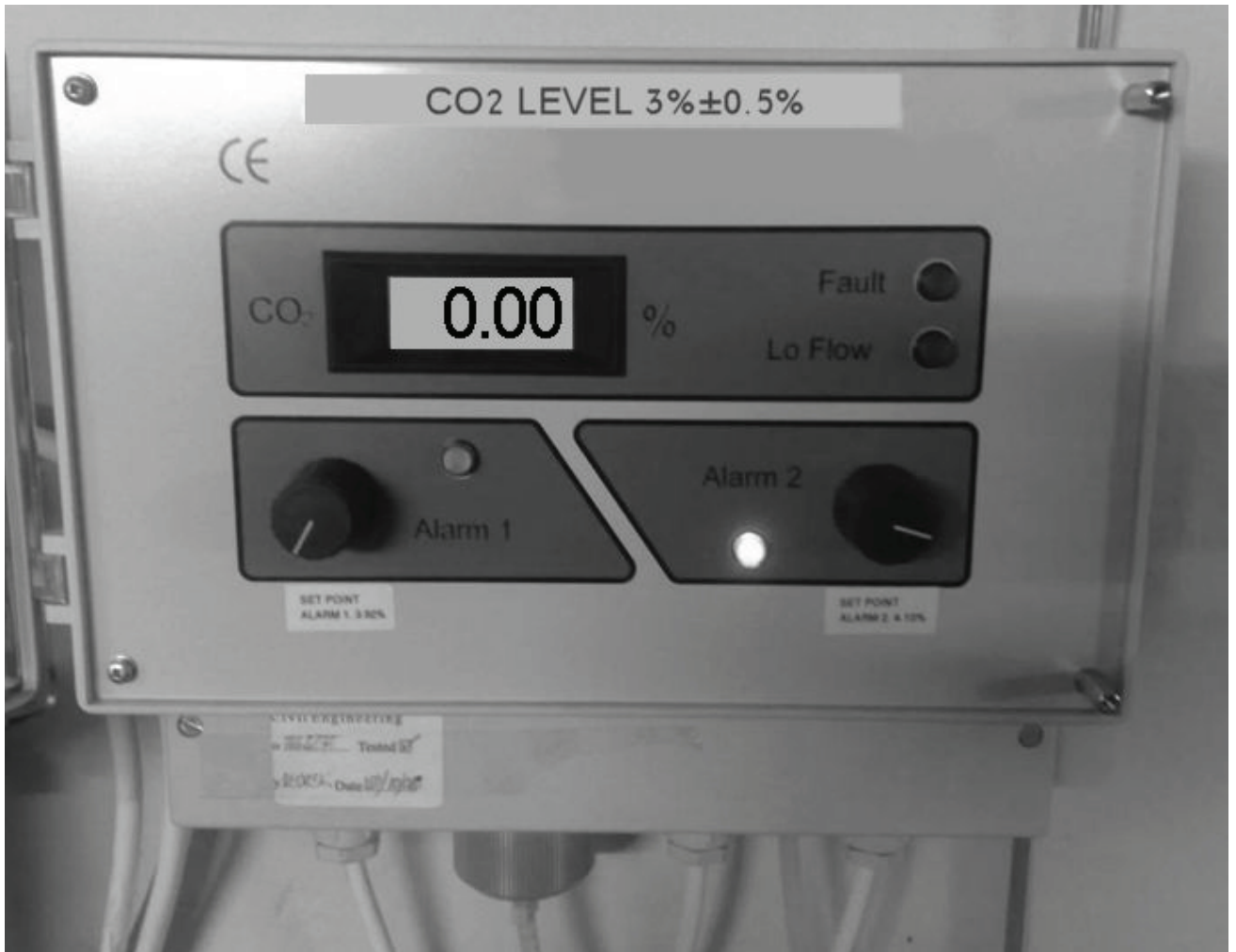
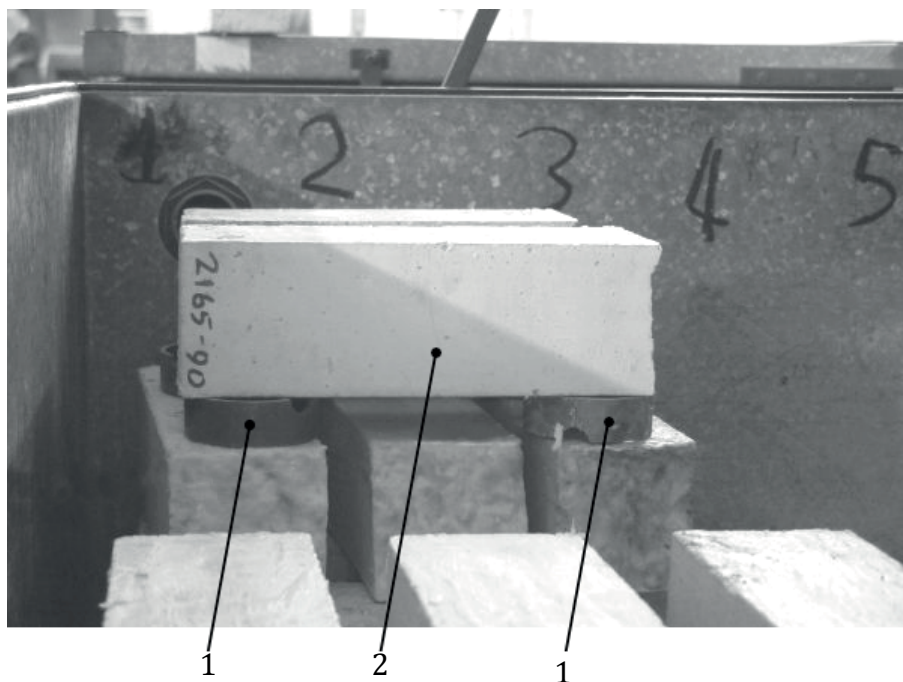

Figure A.3 — Carbon dioxide monitoring/injection apparatus



**Key**

- 1 50 mm plastic spacers
- 2 exposed face of prism

**Figure A.4 — Horizontal storage of specimens**

© International Organization for Standardization

