Testing of concrete —

**Part 11:
Determination of the chloride
resistance of concrete, unidirectional
diffusion**

Essais du béton —

*Partie 11: Détermination de la résistance du béton à la pénétration
des chlorures, diffusion unidirectionnelle*





COPYRIGHT PROTECTED DOCUMENT

© ISO 2013

All rights reserved. Unless otherwise specified, no part of this publication may be reproduced or utilized otherwise in any form or by any means, electronic or mechanical, including photocopying, or posting on the internet or an intranet, without prior written permission. Permission can be requested from either ISO at the address below or ISO's member body in the country of the requester.

ISO copyright office
Case postale 56 • CH-1211 Geneva 20
Tel. + 41 22 749 01 11
Fax + 41 22 749 09 47
E-mail copyright@iso.org
Web www.iso.org

Published in Switzerland

Contents

	Page
Foreword	iv
Introduction	v
1 Scope	1
2 Normative references	1
3 Terms and definitions	1
4 Principle	2
5 Reagents and apparatus	3
5.1 Reagents.....	3
5.2 Apparatus.....	4
6 Preparation of specimens	5
6.1 Preparing sub-specimens.....	5
6.2 Conditioning and preparation of profile specimen for chloride testing.....	6
7 Procedure	7
7.1 Exposure conditions.....	7
7.2 Exposure method.....	8
7.3 Exposure period.....	8
7.4 Determination of initial chloride content (C_i).....	8
7.5 Profile grinding.....	9
7.6 Chloride analysis.....	9
8 Regression procedure and expression of results	9
9 Test report	11
10 Precision	12
Annex A (informative) Diffusion coefficients	13
Annex B (informative) Core test specimen	14
Annex C (normative) Immersion method for large specimens	15
Annex D (informative) Typical equipment and procedure for vacuum saturation	16
Annex E (informative) Procedures of specimen exposure to chloride solution	18
Annex F (informative) Depth intervals of profile specimen grinding	20

Foreword

ISO (the International Organization for Standardization) is a worldwide federation of national standards bodies (ISO member bodies). The work of preparing International Standards is normally carried out through ISO technical committees. Each member body interested in a subject for which a technical committee has been established has the right to be represented on that committee. International organizations, governmental and non-governmental, in liaison with ISO, also take part in the work. ISO collaborates closely with the International Electrotechnical Commission (IEC) on all matters of electrotechnical standardization.

The procedures used to develop this document and those intended for its further maintenance are described in the ISO/IEC Directives, Part 1. In particular the different approval criteria needed for the different types of ISO documents should be noted. This document was drafted in accordance with the editorial rules of the ISO/IEC Directives, Part 2. www.iso.org/directives

Attention is drawn to the possibility that some of the elements of this document may be the subject of patent rights. ISO shall not be held responsible for identifying any or all such patent rights. Details of any patent rights identified during the development of the document will be in the Introduction and/or on the ISO list of patent declarations received. www.iso.org/patents

Any trade name used in this document is information given for the convenience of users and does not constitute an endorsement.

The committee responsible for this document is ISO/TC 71, *Concrete, reinforced concrete and prestressed concrete*, Subcommittee SC 1, *Test methods for concrete*.

ISO 1920 consists of the following parts, under the general title *Testing of concrete*:

Part 1: Sampling of fresh concrete

Part 2: Properties of fresh concrete

Part 3: Making and curing test specimens

Part 4: Strength of hardened concrete

Part 5: Properties of hardened concrete other than strength

Part 6: Sampling, preparing and testing of concrete cores

Part 7: Non-destructive tests on hardened concrete

Part 8: Determination of drying shrinkage of concrete for samples prepared in the field or in the laboratory

Part 9: Determination of creep of concrete cylinders in compression

Part 10: Determination of static modulus of elasticity in compression

Part 11: Determination of the chloride resistance of concrete, unidirectional diffusion

Part 12: Determination of the carbonation resistance of concrete — Accelerated carbonation method

Introduction

Steel reinforced concrete structures exposed to the ingress of chloride, either from seawater or other sources, need to be durable for at least the intended service life. The possibility of reinforcement corrosion is significantly increased as the chloride level at the embedded reinforcement increases. For this reason, the chloride diffusivity or chloride penetrability of the concrete is an important property to measure and this International Standard sets out a test method that may be applied to specimens cast to assess the potential chloride resistance of a concrete mix.

NOTE This test method takes a minimum of 119 days comprising a minimum age of the specimen prior to testing of 28 days, a minimum of one day to prepare and condition the specimen and then 90 days to expose the specimen to the chloride solution. Different periods of curing and exposure may be set (and stated in the test report) in order to adjust the test duration.

Testing of concrete —

Part 11:

Determination of the chloride resistance of concrete, unidirectional diffusion

1 Scope

This part of ISO 1920 specifies a method for determining the unidirectional non-steady-state chloride penetration parameters of conditioned specimens of hardened concrete. The test method enables the determination of the chloride penetration at a specified age, e.g. for ranking of concrete quality by comparative testing.

NOTE 1 The aim of the test is to assess the potential resistance to chloride ingress for a concrete mix.

NOTE 2 Since resistance to chloride penetration depends on ageing, due to the effects of continual hydration of the concrete, the ranking may also change with age.

2 Normative references

The following referenced documents are essential for the application of this part of ISO 1920. For dated references, only the edition cited applies. For undated references, the latest edition of the referenced document (including any amendments) applies.

ISO 1920-3, *Testing of concrete — Part 3: Making and curing test specimens*

ISO 1920-6, *Testing of concrete — Part 6: Sampling, preparing and testing of concrete cores*

3 Terms and definitions

For the purposes of this document, the following terms and definitions apply.

3.1

as-cast surface

surface of a concrete element exposed in the construction works to a chloride environment

3.2

acid-soluble chloride content

amount of acid-soluble chloride expressed in percent by mass of concrete

3.3

chloride penetration

ingress of chlorides into concrete due to exposure to external chloride sources

3.4

diffusion

movement of molecules or ions under a concentration gradient, from a zone of high concentration to a zone with a lower concentration

3.5
diffusion coefficient

proportionality between the molecular flux (e.g. rate of flow of chloride ions) and the concentration gradient in the diffusion equation

Note 1 to entry: In this part of ISO 1920, Fick's Law is adopted as a valid mathematical representation of the chloride ingress mechanism.

Note 2 to entry: See [Annex A](#).

3.6
initial chloride content, C_i

chloride content at a distance sufficiently remote from the surface as to not have been influenced by penetration of the chloride exposure solution

Note 1 to entry: It reflects the initial chloride content that came from the constituents when the concrete was mixed.

3.7
non-steady state diffusion coefficient, D_{nss}
diffusion coefficient that takes into account simultaneous chloride binding

Note 1 to entry: This reflects the rate of diffusion of chloride into a concrete when part of the chloride is being bound by the cement.

Note 2 to entry: See [Annex A](#).

Note 3 to entry: The steady-state chloride diffusion coefficient is measured on water saturated samples where chloride diffuses through a thin specimen between two reservoirs of chloride solution, where one reservoir is at a higher concentration than the other. This steady-state chloride diffusion is not covered by this test method. The steady-state chloride diffusion coefficient only reflects the ionic transport diffusion through concrete, as the concrete is unable to bind any more chloride ion.

3.8
profile grinding

dry process grinding a concrete specimen in thin successive layers

3.9
vacuum saturated condition

specimen that is vacuum saturated with water

4 Principle

A specimen, either a cylinder or cube, is cast and cured in accordance with ISO 1920-3 (see also amendments of the curing conditions in [6.1](#)), for a standard curing period of 28 days.

NOTE 1 A curing period of less than 28 days may be set, depending on the type of cement and purpose of the test.

[Annex B](#) gives guidance on the testing of core specimens, where the core may be sampled from a test element, a precast concrete element or a structure.

The specimen is divided into two sub-specimens: a "profile specimen" that is used to determine the chloride profile after exposure to unidirectional chloride ingress, and an initial chloride sub-specimen that is used to determine the initial chloride level, C_i . This initial figure is taken as the chloride level of the cast concrete.

The profile specimen is vacuum saturated with distilled or demineralized water, coated on all sides but one and then the uncoated face is exposed to a chloride exposure solution. The exposure is achieved by total immersion of the specimen in the chloride exposure solution.

NOTE 2 The test can be performed without vacuum saturating the profile specimen in water; this should be stated in the test report.

NOTE 3 The exposure can be achieved by alternative methods, that are:

- a) ponding the uncoated face of the specimen in the chloride exposure solution;
- b) inverting the specimen and having the uncoated face immersed in the chloride exposure solution.

NOTE 4 The use of large fully immersed specimens is described in [Annex C](#).

The standard reference solution is a 3 % by mass, sodium chloride (NaCl) solution, for an exposure period of 90 days. The solution concentration will be kept constant during the test.

NOTE 5 Other concentrations or solutions, e.g. artificial seawater, and exposure periods other than 90 days, may be set.

After the specified period of exposure, at least eight parallel layers of the chloride exposed surface are ground off the profile specimen. The acid-soluble chloride content of each layer and the average depth of the layer from the surface of the concrete exposed to the chloride solution are determined. The initial chloride content is determined by grinding a sample from the other sub-specimen and having the acid-soluble chloride content determined.

The surface chloride content (C_s) and the non-steady-state chloride diffusion coefficient (D_{nss}) are determined by nonlinear regression analysis using the least squares curve fitting procedure.

Because of the high coefficient of variation, approximately 15 % for D_{nss} for the test, testing of three specimens is required and the results reported separately.

NOTE 6 The chloride diffusion coefficient varies with the age of the concrete and the period of exposure.

NOTE 7 The diffusion test described in this part of ISO 1920 is only valid for a constant initial chloride content.

NOTE 8 When precision information is available for this test, a check on the validity of the two or more results will be introduced plus the determination of the average value.

5 Reagents and apparatus

5.1 Reagents

Reagents of analytical quality shall be used.

NOTE Unless otherwise stated, "percent" means percent by mass.

5.1.1 Calcium hydroxide, $\text{Ca}(\text{OH})_2$

5.1.2 Chloride exposure solution

a) Reference solution

Dissolve 30 g of analytical quality NaCl in 970 g of distilled or demineralized water having an electrical conductivity $\leq 0,5 \text{ mSm}^{-1}$ at 20 °C to produce a 3 % by mass NaCl solution. Store it in a clean container.

NOTE This NaCl solution has a similar chloride concentration to that of seawater.

b) Other exposure solutions

Where the concentration of the chloride exposure solution is other than that in [5.1.2 a\)](#), the concentration shall be recorded and reported. Where a different solution is used, the composition of the solution shall be recorded and reported.

NOTE 1 Natural and artificial seawater have been used to reflect the exposure of the construction works.

NOTE 2 Higher concentrations of NaCl, such as 16,5 %, and shorter exposure periods (e.g. 35 days) may be used to accelerate the development of a chloride profile.

5.1.3 Chloride impervious barrier system

A polyurethane or epoxy-based paint or equivalent barrier system highly resistant to chloride diffusion, to be used in sealing the sides of the specimen.

5.1.4 Chemicals for chloride analysis, complying to a national standard valid in the place of use. The reference number of the national standard shall be stated in the test report.

5.1.5 Distilled or demineralized water, having an electrical conductivity $\leq 0,5 \text{ mSm}^{-1}$.

5.2 Apparatus

5.2.1 Water cooled diamond saw

5.2.2 Balance for weighing NaCl and water, capable of weighing to an accuracy of $\pm 0,1 \text{ g}$.

5.2.3 Thermometer, capable of measuring to an accuracy of $\pm 1 \text{ }^\circ\text{C}$.

5.2.4 Temperature controlled chamber, capable of keeping a temperature of $(20 \pm 2) \text{ }^\circ\text{C}$.

5.2.5 Where used, a polyethylene container with airtight lid for immersion of the profile specimen. The volume of the exposure solution shall exceed the volume of the specimen by not less than 12,5 ml per square centimetre of exposed surface. A container may contain more than one sample provided the ratio of exposure solution to exposed surface shall be recorded and reported.

NOTE During the test, the chloride concentration of the chloride exposure solution reduces and if the ratio of the volume of chloride exposure solution to exposure surface varies, the rate of reduction will vary with nominally identical concrete. For this reason if a direct comparison of results from different specimens is required, the ratio of the volume of chloride exposure solution to exposed surface should be constant.

5.2.6 Where used, pond to be attached to profile specimen. The ponds shall have a constant diameter and initial depth not less than 125 mm.

5.2.7 Equipment for grinding off and collecting concrete powder in layers 1 mm or more deep, capable of grinding a surface area of at least 4000 mm^2 and not grinding within 10 mm of the edge of the test area.

5.2.8 Compressed air or air blower, to clean dust from specimen and equipment between grinding layers.

5.2.9 Dust collecting bags

5.2.10 Equipment for chloride content testing, in accordance with a national standard valid in the place of use. The reference number of the national standard shall be stated in the test report.

5.2.11 Calliper, measuring to an accuracy of $\pm 0,1 \text{ mm}$.

5.2.12 Vacuum container, capable of containing at least three specimens.

5.2.13 Vacuum pump, capable of maintaining an absolute pressure of less than 50 mbar (5 kPa) in the container, e.g. a water-jet pump.

6 Preparation of specimens

6.1 Preparing sub-specimens

A specimen size shall be selected such that after cutting, the minimum dimension of the sub-specimens used to determine a chloride profile is at least three times the nominal maximum aggregate size. Three specimens, either cylinders, 100 mm or greater in diameter or cubes, 100 mm or greater are cast, and cured for a period of 28 days in a water filled bath with a temperature of $(20 \pm 2) ^\circ\text{C}$, in accordance with ISO 1920-3. In hot climate locations, the curing conditions after removal of the specimen from the mould can be different from those mentioned in ISO 1920-3. In this case, the specimens may be stored in water at a temperature of $(27 \pm 2) ^\circ\text{C}$ or in a chamber having a temperature of $(27 \pm 2) ^\circ\text{C}$ and a relative humidity of at least 95 %.

NOTE A curing period other than 28 days may be set, depending on the type of cement and purpose of the test.

After 28 days of standard curing or the specified curing period (see the above note), each cylinder or cube is cut into two sub-specimens using the water cooled diamond saw. Cylindrical specimens are cut in the direction parallel to the flat surface and cubical specimens are cut in the direction parallel to the top (trowelled) surface as shown in [Figure 1](#). No dimension of the sub-specimens used to determine a chloride profile shall be less than three times the nominal maximum aggregate size. One sub-specimen (called the “profile specimen”) is used to determine the chloride profile, and the initial chloride sub-specimen is used to determine the initial chloride content. This initial chloride content is taken as being the chloride content of the cast concrete. The adjacent sawn faces are used to determine these values.

NOTE 2 Where a chloride profile is required that incorporates the effect of a formed surface then a formed surface from a cube specimen may be specified as the surface for chloride exposure. However, the results from such a procedure are difficult to interpret due to concentrations of cement paste and chloride at the formed surface. The use of this approach should be reported under [Clause 9, m](#)), as it is a non-standard test condition.

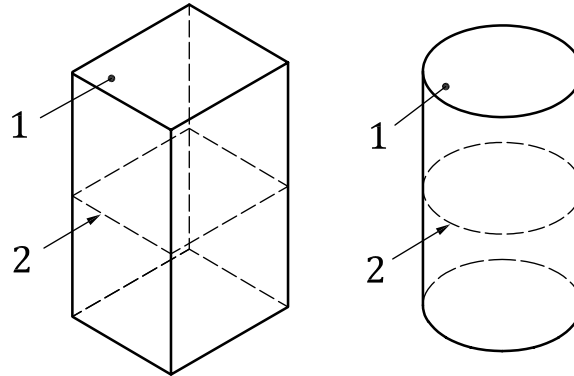

Key

- 1 trowelled surface
- 2 cut to separate specimens and produce exposure surface

Figure 1 — Specimen preparation

After sawing, the sub-specimen to be used to determine the initial chloride content shall be placed in a close fitting sealed plastic bag or tested immediately.

Where needed, the sub-specimens may be cut to reduce their size to aid handling, but the sub-specimen for determining the chloride profile shall not have a dimension less than three times the nominal maximum aggregate size.

6.2 Conditioning and preparation of profile specimen for chloride testing

6.2.1 Vacuum saturation of the profile specimens

After sawing the specimens, vacuum saturate the profile specimens with water. [Annex D](#) shows a typical arrangement for vacuum saturation. Place the profile specimens in the vacuum container and reduce the absolute pressure to a value between 10 mbar and 50 mbar (1 kPa to 5 kPa) within a few minutes of closing the container. Maintain this absolute pressure for 3 h and then with the vacuum pump still running, fill the container with distilled or demineralized water so that all the profile specimens are immersed. Maintain the absolute pressure for a further hour before allowing air to re-enter the container.

Leave the profile specimens immersed in water until the process of surface sealing starts.

The test may be carried out without vacuum saturating the profile specimen in water, as described in this clause. If the profile specimen is not vacuum saturated in water, this shall be mentioned in the test report in order to allow comparison of the test results obtained by the same procedure.

6.2.2 Sealing surfaces other than the surface to be exposed

6.2.2.1 General

Start the sealing within 24 h of completing the vacuum saturation or the standard curing (if no vacuum saturation was carried out). All surfaces of the profile specimen except for the sawn face shall be sealed, see [Annex C](#) for an exception. After sealing the surfaces, place the specimens in saturated calcium hydroxide solution for at least 18 h.

NOTE The purpose of sealing the faces other than the face exposed to the chloride solution is to ensure that the ingress of chloride ions into the concrete is a pure unidirectional diffusion process and not a mixture of diffusion and other processes, e.g. capillary suction.

6.2.2.2 Sealing procedures

- a) Specimens exposed to chloride solution by immersion – standard reference method.

The profile specimen shall be dried in laboratory air until its surface is “white-dry”.

NOTE This usually takes between 2 h and 4 h.

All faces except the face to be exposed to the chloride solution shall be coated with a layer of epoxy or polyurethane or equivalent making sure that the surface to be tested remains free of the coating material. The coating material shall be applied and cured in accordance with the recommendations of the manufacturer.

- b) Specimens exposed to the chloride solution by alternate methods.

- 1) Exposure by ponding:

- i) as described in [6.2.2.2 a\)](#) for specimens exposed by immersion, or
- ii) dry the surfaces with a cloth to remove free water and wrap the surface with one or three layers of a polymeric or composite self-amalgamating tape with a low water vapour transmission rate (for instance aluminium foil tape or parafinated polymeric film), ensuring sufficient overlap of joints.

NOTE If one layer is applied, [7.2.2 b\)](#) requires additional protection.

- 2) Exposure by inversion:

- i) as described in [6.2.2.2 a\)](#) for specimens exposed by immersion.

6.2.3 Exposure of specimens to the chloride solution

- a) Profile specimen for immersion – standard reference method.

After storage in saturated calcium hydroxide solution, the specimen shall be transferred directly to exposure without surface drying. A suitable arrangement is shown in [Annex E](#).

- b) Profile specimen for exposure by alternative methods.

- 1) Profile specimen for ponding:

After storage in saturated calcium hydroxide solution, a pond is sealed to the surface of the specimen in a manner that prevents leakage of the chloride exposure solution. A suitable arrangement is shown in [Annex E](#), noting that the volume of the pond is as defined in [5.2.6](#). The external border between the plastic tube and specimen is sealed to prevent leakage. The diameter of the tube used to form the pond may be 10 mm to 20 mm less than the diameter of the specimen to allow the formation of a watertight seal. The surface not covered by the pond shall be completely sealed using the sealant or the tape defined in [6.2.2.2 b](#)).

NOTE At the edge of such specimens, there will not be unidirectional chloride ingress.

An alternative technique is to use a slightly larger tube and a rubber gasket between the tube and the sealed side of the specimen.

- 2) Profile specimen for inversion:

After sealing in accordance with [6.2.2](#) and storage in the calcium hydroxide solution, the specimen shall be transferred directly to the inversion exposure apparatus without surface drying. A suitable arrangement is shown in [Annex E](#). The volume of the exposure solution shall not be less than 12,5 ml per square centimetre of exposed surface.

7 Procedure

7.1 Exposure conditions

7.1.1 Chloride exposure solution

Unless specified otherwise, the chloride exposure solution shall be a 3 % NaCl solution in accordance with [5.1.2 a](#)) If the chloride exposure solution is other than the reference solution [see [5.1.2 b](#))], it shall be reported. The chloride exposure solution concentration after use shall be measured and recorded.

NOTE 1 Where testing is related to the intended use in a specific exposure condition, the chloride exposure solution should reflect the exposure conditions taking into account the expected depletion of chloride.

NOTE 2 During the test period the concentration of the chloride exposure solution will reduce. The volume of chloride exposure solution has been selected so that it does not have to be replaced during a test lasting 90 days. If a longer test period is required, the chloride exposure solution should be replaced at 91 day intervals.

NOTE 3 Fick's Law is based on the assumption that the external chloride concentration remains constant during the duration of the test. In the normal test situation, the error introduced by assuming that the chloride concentration remains constant at the initial concentration is small.

7.1.2 Exposure temperature

Where used, the temperature of the water bath for the immersion specimen, the temperature of the chloride exposure solution in the inversion method and the temperature of the chamber used to store the ponded specimen shall be maintained at (20 ± 2) °C and confirmed at least once per day and the mean and range over the duration of the test reported.

7.2 Exposure method

7.2.1 General

The exposed (sawn) surface of the profile specimens shall be in direct contact with the chloride exposure solution either by immersion, ponding or inversion. The age of the specimen when it is first exposed to the chloride exposure solution shall be recorded and reported.

7.2.2 Exposure procedure

a) Immersion – standard reference method.

Profile specimens to be immersed shall be placed within the container containing the chloride exposure solution and the container completely filled with the solution and sealed. This sealed container shall be placed in the water bath.

b) Alternative exposure methods.

1) Ponding:

For ponded specimens, the pond shall be completely filled with chloride exposure solution and then sealed with a plastic film. The whole assembly is then placed within a closed chamber maintaining a relative humidity $\geq 95\%$. If the high relative humidity is achieved by partial filling of the chamber with water, the specimens shall be kept in a manner that prevents direct contact with this water.

If the ambient relative humidity of the chamber is lower than 100 %, for example when using a fog room for curing concrete specimens, and the lateral faces of the specimens have been sealed with one layer of tape, then wrap the lateral faces of the specimens with two additional layers of the same tape or polyethylene plastic film to avoid completely the possibility of drying the concrete.

2) Inversion:

The profile specimen is turned upside down and placed with the exposure surface immersed in the chloride exposure solution. It shall be fixed in a manner that ensures the whole exposed surface being in contact, and remaining in contact, with the solution, e.g. supported on an open mesh that is fixed below the surface of the chloride exposure solution. The specimens shall be placed in the solution in a manner that minimizes the risk of entrapped air. The chamber shall be sealed to prevent evaporation.

7.3 Exposure period

The reference period of chloride exposure is 90 days. The exposure period may be different than 90 days, depending on the concrete components and the mixing conditions.

7.4 Determination of initial chloride content (C_i)

Recover the initial chloride content specimen from the plastic bag. Approximately a 1 mm layer shall be ground from the sawn surface of the initial chloride content specimen and discarded. The same surface is then ground to obtain a 20 g sample of dust for chloride analysis. The acid-soluble chloride content is determined in accordance with a national standard valid in the place of use and expressed as percentage by mass of concrete and it is designated C_i . The reference number of the national standard shall be stated in the test report.

If a number of specimens have been produced from a single batch of concrete, the initial chloride content may be determined from a single specimen.

7.5 Profile grinding

After 90 days and within 8 h of removing the specimen from the exposure solution, at least eight parallel layers of the profile specimen shall be dry ground where each layer gives a sample of not less than 5 g of dry concrete, and where the outermost layer also has a thickness of not less than 1,0 mm. The thickness of the layers shall be adjusted according to the expected chloride profile so that a minimum of six points covers the profile between the exposed surface and a depth where the chloride content is above the initial chloride content. Recommended depth intervals of profile grinding for Portland cement concrete and for concretes containing fly ash, GGBS or silica fume are given in [Annex F](#).

NOTE 1 The values in [Annex F](#) may not be appropriate for more mature concrete or concrete taken from existing structures.

NOTE 2 In normal circumstances all seven layers would be included in the profile (the surface layer value is not included in the profile). The criterion for a minimum of six points is to prevent the whole test being made invalid if one layer is shown to be an outlier.

After grinding, keep the remainder of the profile specimen in a close fitting sealed plastic bag until the profile has been calculated. If the chloride content in the deepest layer is more than $C_i + 0,015$ %, grind off further layers so that a complete profile is established. To ensure that a complete profile has been achieved, i.e. the exposure solution has not penetrated the whole profile specimen, the last layer shall be at a depth of not less than the profile specimen thickness less 10 mm.

The concrete specimens shall be dry ground and grinding shall be performed over a surface area of at least 40 cm² and within a boundary 10 mm inside the boundary of the contact zone to avoid edge effects and disturbances from the coating.

The profile specimen shall be securely fixed parallel to the grinder and a dust collection bag, e.g. a plastic bag, shall be fixed in position to collect the dust. Each layer should produce at least 5 g of dust. After grinding each layer, clean the equipment and profile specimen surface of any residual dust with compressed air or an air blower, then measure the depth of the layer. The depth of the layer is calculated as the mean of five evenly distributed measurements using the calliper rule.

The concrete dust of each layer is collected in marked plastic bags to be analysed for chloride concentration. Each bag shall be clearly marked with the sub-specimen reference, depth interval and date.

7.6 Chloride analysis

The acid-soluble chloride content of each ground sample shall be determined in accordance with a national standard valid in the place of use. The reference number of the national standard shall be stated in the test report.

8 Regression procedure and expression of results

The second layer from the surface is the first point used in the regression analysis.

Determine the depth where the chloride content first reaches a value between C_i and $C_i + 0,015$ %. This is the last point used in the regression analysis and it is called the "zero point". If this point has not been reached, further layers shall be ground from the profile specimen until the initial chloride content has been reached. Layers deeper than the point are excluded from the regression analysis as is the surface layer.

The calculated chloride content at the surface (C_s) and the non-steady-state chloride diffusion coefficient (D_{NSS}) shall be determined by fitting Formula (1) to the relevant points by means of a nonlinear regression analysis by least squares, as illustrated in [Figure 2](#), and where the surface layer of the profile is omitted.

$$C_x = C_i + (C_s - C_i) \left(1 - \operatorname{erf}_{(x)} \left[\frac{x}{2 \sqrt{D_{\text{NSS}} t}} \right] \right) \quad (1)$$

where

C_x is the chloride content measured at average depth x and exposure time t , % by mass of concrete;

C_s is the calculated chloride content at the exposed surface, % by mass of concrete;

C_i is the initial chloride content, % by mass of concrete;

x is the depth below the exposed surface to the mid point of the ground layer, in metres (m);

D_{NSS} is the non-steady-state chloride diffusion coefficient, in square metres per second ($\text{m}^2 \text{s}^{-1}$);

t is the exposure time, in seconds (s);

$\operatorname{erf}_{(x)}$ is the error function defined in Formula (2),

where

$$\operatorname{erf}_{(x)} z = \frac{2}{\sqrt{\pi}} \int_0^z \exp(-u^2) du \quad (2)$$

Values for $\operatorname{erf} z$ are given in widely available software packages.

NOTE 1 The values of C_s and D_{NSS} should not be used to estimate chloride penetration for conditions other than those used in the test.

NOTE 2 The results of this test may be expressed in different ways, e.g. as a penetration parameter or the depth to reach the critical chloride content.

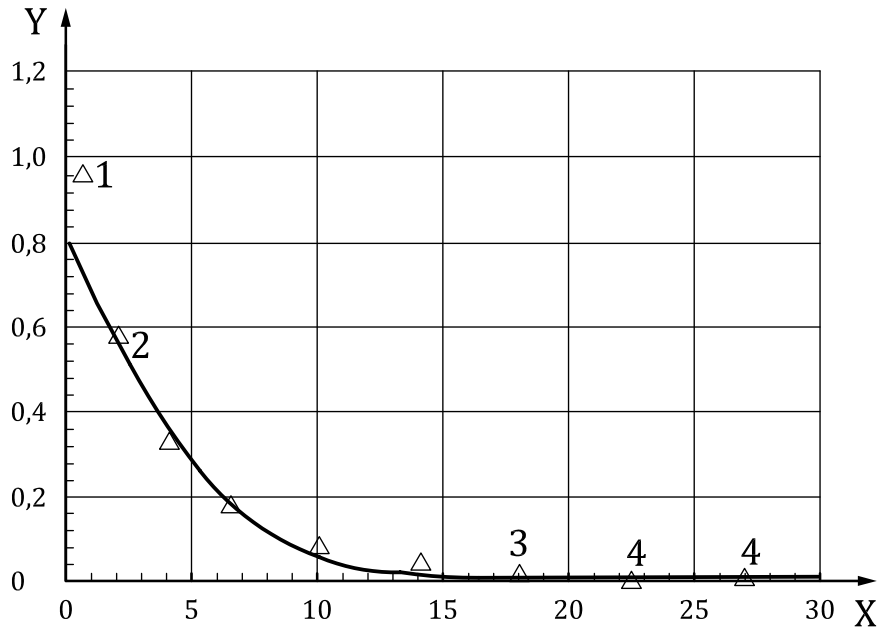
**Key**

- Y chloride content, % by mass of concrete
 X depth, in millimetres (mm)
 1 the first point is always excluded from curve-fitting
 2 this is the first point used in the regression analysis
 3 the “zero-point”
 4 points after “zero-point” are excluded from curve-fitting

Figure 2 — Illustration of regression analysis

9 Test report

The test report shall include:

- a) identification of the test specimens;
- b) description of the specimen including its age at the start of the test when known;
- c) date and start of the test;
- d) duration of the test;
- e) curing period if other than 28 days;
- f) a statement that the test was carried out without vacuum saturating the profile specimen, if relevant;
- g) chloride exposure solution if other than a 3 % NaCl solution;
- h) initial and final NaCl concentration of test solution;
- i) exposure period to chloride solution, if other than 90 days;
- j) method of exposure (by immersion, ponding or inversion);
- k) mean temperature plus highest and lowest temperature of the chloride exposure solution;
- l) volume of chloride solution per exposed surface (in millilitres per square centimetre (ml cm⁻²));

- m) individual chloride measurements and the depth they represent;
- n) reference number of the national standard according to which the acid-soluble chloride content was determined;
- o) initial chloride content, C_i , % by mass of concrete;
- p) calculated boundary condition at the exposed surface, C_s , % by mass of concrete;
- q) calculated non-steady-state chloride diffusion coefficient, D_{nss} , in square centimetres per second ($m^2 s^{-1}$) for each specimen, the correlation coefficient and the number of points in the regression;
- r) average value of the non-steady-state chloride diffusion coefficient, D_{nss} , and of the calculated chloride concentration at the exposed surface, C_s ;
- s) any deviation from the standard test method;
- t) a declaration by the person technically responsible for the test that it was carried out in accordance with this part of ISO 1920, except as noted in s).

10 Precision

There are no precision data available.

NOTE The following coefficients of variation for single test results are to be expected: C_s approximately 20 % and D_{nss} approximately 15 %.

Annex A (informative)

Diffusion coefficients

Following Crank, the diffusion coefficient is defined (see [Figure A.1](#)) as the rate of transfer of the diffusing substance across a unit area of a section divided by the space gradient of concentration at the section:

$$D = -\frac{F}{\partial c / \partial x}, \text{ m}^2/\text{s} \quad (\text{A.1})$$

where

F is the flow rate (flux) in moles per square metre per second ($\text{mol m}^{-2}\cdot\text{s}$);

$\partial c / \partial x$ is the gradient of concentration with the concentration, in moles per cubic metre (mol/m^3).

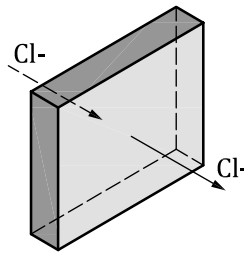

Figure A.1 — Unit section for defining chloride flow

This definition pays attention to the importance of the units of D and the coherence of them in the whole expression. For concrete, chloride content is used instead of concentration, which is used for common electrolytic solutions.

As some of the chloride ions may react with or get bound to the cement phases, it is necessary for the sake of the testing to distinguish at least two kinds of diffusion coefficients:

- *Steady-state diffusion coefficient*: this is where a constant flux of chloride ions is reached during the time of testing. The concentration of chlorides is given in units of moles (mol) of chlorides per cubic metre (m^3) of test solution. Due to the test conditions, the resulting calculated diffusion coefficient does not take into account the potential of such a concrete to bind chloride ion.
- *Non-steady-state diffusion coefficient*: this is where the flow of chloride ions is not constant during the time of testing. The concentration of chlorides is expressed as percent (%) by mass of cement or concrete, or in kilograms per cubic metre (kg m^{-3}) of concrete. Due to the test conditions, the resulting calculated diffusion coefficient takes into account the ability of the concrete to bind chlorides.

Annex B (informative)

Core test specimen

The age of the concrete in the structure from which the core specimens are to be obtained should be 28 maturity days, where one maturity day is the time to develop a maturity corresponding to curing under water for one day at 20 °C or at 27 °C in hot climate conditions. The age and any information on the curing of the element shall be recorded and reported.

The core(s) shall be taken in accordance with ISO 1920-6. Where a core is taken from an existing structure, it is essential that the profile specimen is from a zone that has not been subject to external chloride ingress.

NOTE If the purpose of the test is to be representative of durability performance of an existing structure, it is important that the concrete tested is taken from the cover zone, which is the concrete that covers the reinforcing steel. The outer 10 mm of a core (the cover) is known to have higher concentrations of cement paste that may influence the recorded C_s and D_{ns} and it is often cut off and discarded and the test undertaken on the sawn surface 10 mm from the structure's surface. This also applies for cast specimens as shown in [Figure 1](#). It is essential to ensure that when testing the cover of existing structures, the specimen does not already have a chloride gradient. Where this procedure is used, the deviations from this test method should be recorded.

[Figure B.1](#) shows the relative positions of the as-cast surface, profile specimen and initial chloride specimen for a core specimen when used to determine the diffusion coefficient of the cover zone of an existing structure provided there is no existing chloride gradient.

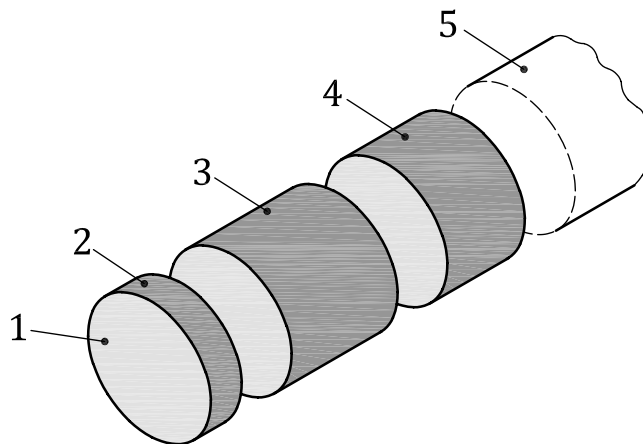

Key

- 1 as-cast surface
- 2 discard outer 10 mm
- 3 for chloride profile (the dimensions shall comply with [6.1](#))
- 4 20 mm to establish initial chloride content
- 5 inner core

Figure B.1 — Specimen and sub-specimens from a core specimen

Annex C (normative)

Immersion method for large specimens

Large specimens are those that are sufficiently large for the zone from which the powder samples are ground to be unaffected by two- and three-dimensional ingress of chloride ions when the whole specimen is immersed. Where this technique is used, the ratio of the exposed area of the specimen to the volume of exposure solution shall be as given in 5.2.5. An example of a suitable arrangement is shown in [Figure C.1](#).

Where a large specimen has been used without sealing the non-test surfaces, the grinding shall be performed within a boundary 50 mm inside specimen boundary to avoid edge effects.

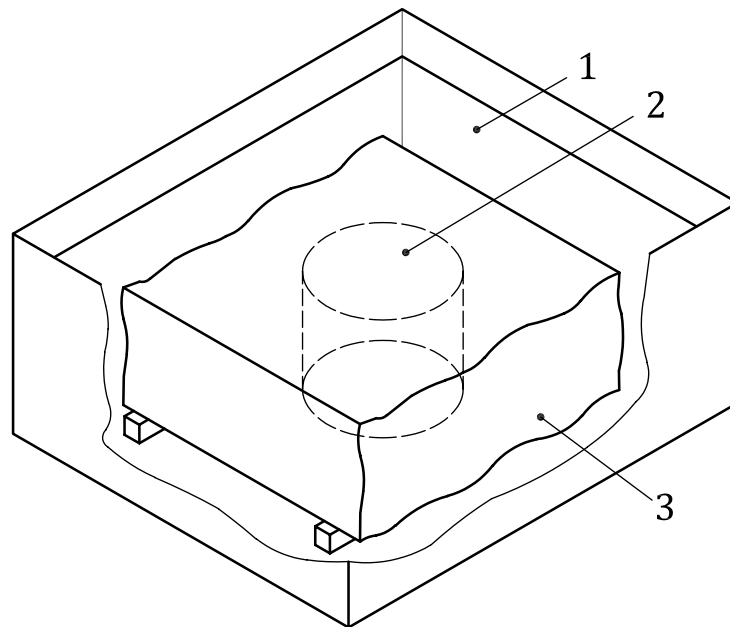

Key

- 1 chloride solution not less than 12,5 ml per square centimetre of exposed surface;
- 2 profile grinding performed not less than 50 mm inside specimen boundary;
- 3 surface unsealed.

Figure C.1 — Example of a large immersed specimen

Annex D (informative)

Typical equipment and procedure for vacuum saturation

D.1 Apparatus

Figure D.1 shows a typical set of equipment used to perform the vacuum saturation of concrete specimens.

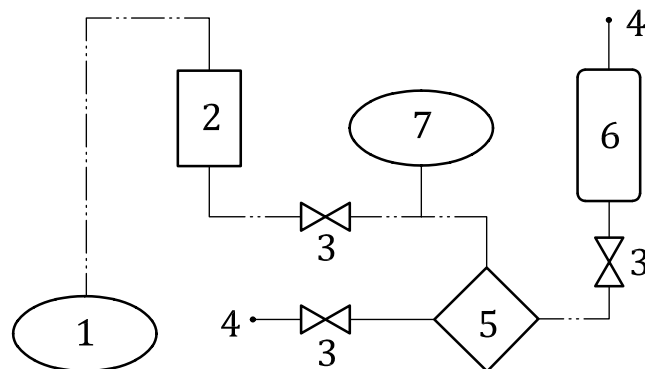

Key

- 1 vacuum pump
- 2 water trap
- 3 valve
- 4 air connection
- 5 vacuum chamber
- 6 water reservoir
- 7 pressure gauge/manometer

Figure D.1 — Typical arrangement of equipment used for vacuum saturating concrete specimens

D.1.1 Water reservoir, bottom-draining container of 500 ml or larger.

D.1.2 Water chamber, with an internal diameter of at least 250 mm fitted with three outlets to connect the water reservoir, the vacuum pump and the atmosphere.

D.1.3 Manometer/pressure gauge, accuracy of 1 mbar.

D.1.4 Water trap, it should be used to protect the vacuum pump from water. If a water trap is not used, the pump oil shall be changed after each operation.

D.1.5 Vacuum pump, capable of reducing the pressure to between 10 mbar and 50 mbar.

D.1.6 Three valves and fluid lines, to connect and control fluid flow.

D.2 Procedure

- a) Place the profile specimens in the vacuum container and close the valves to the container.
- b) Open the vacuum line valve and turn on the vacuum pump to reduce the absolute pressure to 10 mbar to 50 mbar (1 kPa to 5 kPa), which should only take a few minutes, and maintain this absolute pressure for 3 h.
- c) With the vacuum pump still running, open the water line valve for the time needed to fill the container with distilled or demineralized water from the attached reservoir. All the specimens should be completely immersed in water. During this operation ensure that air does not enter the vacuum pump through the water line.
- d) Maintain the vacuum for a further one hour.
- e) Close the vacuum line valve and turn off the vacuum pump.
- f) Open the vacuum line valve and allow air to re-enter the container.

Annex E (informative)

Procedures of specimen exposure to chloride solution

E.1 Profile specimen for immersion

[Figure E.1](#) shows a suitable arrangement.

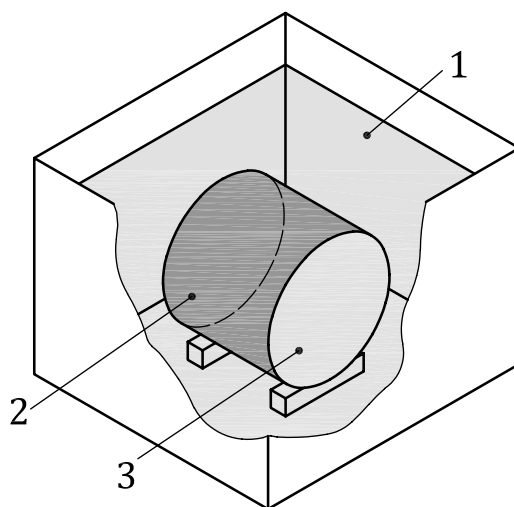

Key

- 1 chloride solution not less than 12,5 ml per square centimetre of exposed surface of completely immersed specimen
- 2 sealed surfaces
- 3 exposed surface

Figure E.1 — Example of an immersed specimen and sealed surfaces

E.2 Profile specimen for ponding

[Figure E.2](#) shows a suitable arrangement.

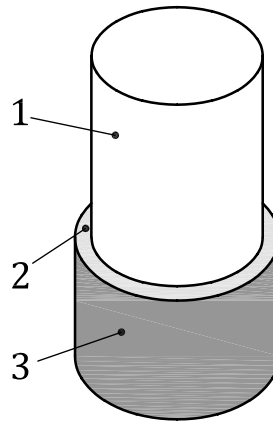

Key

- 1 pond
- 2 seal
- 3 profile specimen

Figure E.2 — Example of a profile specimen and pond sealed to surface

E.3 Profile specimen for inversion

[Figure E.3](#) shows a suitable arrangement

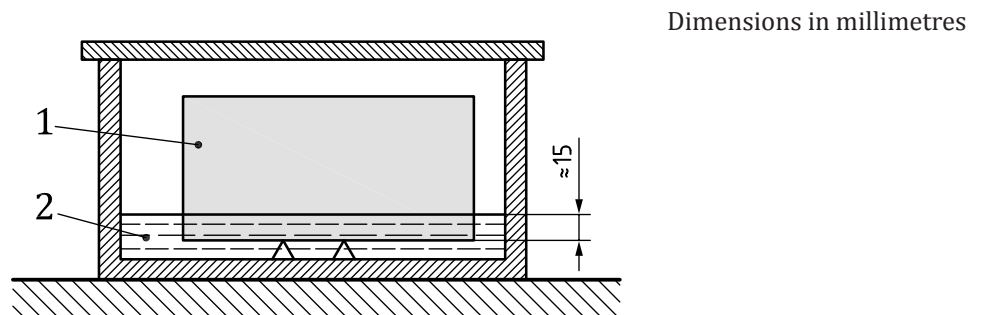

Key

- 1 sealant on specimen
- 2 NaCl solution

Figure E.3 — Example of an inversion specimen and exposure apparatus

Annex F (informative)

Depth intervals of profile specimen grinding

Recommended depth intervals of grinding for specimens made of Portland cement are given in [Table F.1](#).

Table F.1 — Recommended depth intervals of profile specimen grinding for Portland cement concrete

Dimensions in millimetres

Layer	Water/cement ratio					
	0,30	0,35	0,40	0,50	0,60	0,70
Layer 1	0~1	0~1	0~1	0~1	0~1	0~1
Layer 2	1~2	1~2	1~3	1~3	1~3	1~5
Layer 3	2~3	2~3	3~5	3~5	3~6	5~10
Layer 4	3~4	3~5	5~7	5~8	6~10	10~15
Layer 5	4~6	5~7	7~10	8~12	10~15	15~20
Layer 6	6~8	7~9	10~13	12~16	15~20	20~25
Layer 7	8~10	9~12	13~16	16~20	20~25	25~30
Layer 8	10~12	12~16	16~20	20~25	25~30	30~35

Recommended depth intervals of grinding for specimens made of concrete containing GGBS, fly ash or silica fume are given in [Table F.2](#).

Table F.2 — Recommended depth intervals of profile specimen grinding for concrete containing GGBS, fly ash or silica fume

Dimensions in millimetres

Layer	Water/cement ratio ^a					
	0,30	0,35	0,40	0,50	0,60	0,70
Layer 1	0~1	0~1	0~1	0~1	0~1	0~1
Layer 2	1~2	1~2	1~2	1~3	1~3	1~3
Layer 3	2~3	2~3	2~3	3~5	3~5	3~6
Layer 4	3~4	3~4	3~5	5~7	5~8	6~10
Layer 5	4~5	4~6	5~7	7~10	8~12	10~15
Layer 6	5~6	6~8	7~9	10~13	12~16	15~20
Layer 7	6~8	8~10	9~12	13~16	16~20	20~25
Layer 8	8~10	10~12	12~16	16~20	20~25	25~30

^a Where the concrete contains GGBS, fly ash or silica fume, the water/cement ratio shall be calculated as required by the national standard, valid in the place of use.

