

---

# International Standard



# 1897/11

---

INTERNATIONAL ORGANIZATION FOR STANDARDIZATION • МЕЖДУНАРОДНАЯ ОРГАНИЗАЦИЯ ПО СТАНДАРТИЗАЦИИ • ORGANISATION INTERNATIONALE DE NORMALISATION

---

## **Phenol, *o*-cresol, *m*-cresol, *p*-cresol, cresylic acid and xyleneols for industrial use — Methods of test — Part 11 : Determination of crystallizing point (Excluding cresylic acid and xyleneols)**

*Phénol, o-crésol, m-crésol, p-crésol, acide crésylique et xylénols à usage industriel — Méthodes d'essai — Partie 11 : Détermination du point de cristallisation (Acide crésylique et xylénols exclus)*

**First edition — 1983-11-01**

---

**UDC 661 : 547.562/.563 : 532.78**

**Ref. No. ISO 1897/11-1983 (E)**

**Descriptors :** industrial products, chemical compounds, phenols, phenol, cresols, xyleneols, chemical analysis, determination, crystallization.

Price based on 4 pages

## Foreword

ISO (the International Organization for Standardization) is a worldwide federation of national standards bodies (ISO member bodies). The work of developing International Standards is carried out through ISO technical committees. Every member body interested in a subject for which a technical committee has been authorized has the right to be represented on that committee. International organizations, governmental and non-governmental, in liaison with ISO, also take part in the work.

Draft International Standards adopted by the technical committees are circulated to the member bodies for approval before their acceptance as International Standards by the ISO Council.

International Standard ISO 1897/11 was developed by Technical Committee ISO/TC 47, *Chemistry*, and was circulated to the member bodies in October 1982.

It has been approved by the member bodies of the following countries :

Australia	France	Nigeria
Austria	Germany, F.R.	Poland
Belgium	Hungary	Portugal
Bulgaria	India	Romania
China	Italy	South Africa, Rep. of
Czechoslovakia	Netherlands	Switzerland
Egypt, Arab Rep. of	New Zealand	USSR

No member body expressed disapproval of the document.

This International Standard cancels and replaces ISO Recommendation R 1901-1971, of which it constitutes a technical revision.

© International Organization for Standardization, 1983 ●

Printed in Switzerland

# Phenol, *o*-cresol, *m*-cresol, *p*-cresol, cresylic acid and xyleneols for industrial use — Methods of test — Part 11 : Determination of crystallizing point (Excluding cresylic acid and xyleneols)

## 1 Scope and field of application

This part of ISO 1897 specifies a method for the determination of the crystallizing point of phenol, *o*-cresol, *m*-cresol and *p*-cresol for industrial use:

The test may be carried out on products, as received in the undried condition, or on a dried sample. In the latter case, apply the drying method specified in ISO 2208.

This document should be read in conjunction with ISO 1897/1 (see the annex).

## 2 References

ISO 1392, *Determination of crystallizing point — General method.*

ISO 2208, *Phenol, o-cresol, m-cresol and p-cresol for industrial use — Determination of crystallizing point after drying with a molecular sieve.*

## 3 Principle

Cooling the liquid or liquefied test portion, and determination of the crystallizing point by observation of the temperature during crystallization under defined conditions.

## 4 Apparatus

NOTE — On the basis of the apparatus specified in clause 4 of ISO 1392, which may, however, be used, a simplified apparatus has been developed for the determination of the crystallizing point of phenol, *o*-cresol, *m*-cresol and *p*-cresol, taking into account the properties of these products.

Ordinary laboratory apparatus, and

**4.1 Crystallizing point apparatus** (see the figure), consisting of

**4.1.1 Crystallizing tube**, nominal dimensions 150 mm ×  $\phi$  25 mm, sealed with a stopper, which carries the stirrer (4.1.2)

and the thermometer (4.2). The thermometer is so fixed in the stopper that the bottom of the bulb is about 15 mm from the bottom of the crystallizing tube.

**4.1.2 Stirrer**, of glass, with a loop of outside diameter 18 mm, to surround the thermometer (4.2).

**4.1.3 Outer protection tube**, nominal dimensions 160 mm ×  $\phi$  38 mm, weighted with lead shot or similar material. This tube is flanged so that it may be supported centrally in the metal plate covering the water bath (4.1.4).

**4.1.4 Water bath**, consisting of a 1 000 ml tall-form beaker containing water to within 20 mm of the top and covered with a metal plate. This plate has two holes, one in the centre which carries the outer protection tube (4.1.3) and the other, to one side, through which the thermometer (4.3) passes and is held by a rubber ring.

**4.2 Thermometer for precision use**, STL/0,1/−5/+25 or STL/0,1/20/45, 100 mm partial immersion, complying with the requirements of ISO 653.

**4.3 Thermometer, general purpose**, C "75" complying with the requirements of ISO 1770.

## 5 Procedure

### 5.1 Test portion

Take 20 ml of the laboratory sample.<sup>1)</sup>

NOTE — If the laboratory sample is in the form of a solid crystalline mass or contains crystals, it should be completely melted and thoroughly mixed before sampling, precautions being taken against overheating or contamination by moisture.

If so required, dry the sample as specified in ISO 2208.

### 5.2 Determination

Transfer the test portion (5.1) directly into the crystallizing tube (4.1.1), and insert the stopper carrying the appropriate ther-

1) The sampling of liquid chemical products for industrial use will form the subject of a future International Standard.

**ISO 1897/11-1983 (E)**

nometer (4.2) and the stirrer (4.1.2). If the test portion has started to crystallize, heat gently until it melts completely again and then cool rapidly to determine the approximate crystallizing point. Warm the tube in the water bath (4.1.4) at a temperature about 5 °C above this point, so that the crystals melt, except for a trace necessary for seeding.

Replace the crystallizing tube (4.1.1) in its jacket (4.1.3) with the water in the apparatus maintained at a temperature between 6 and 8 °C below the expected crystallizing point. Stir the test portion **gently and continuously** and record the thermometer readings at 30 s intervals.

The crystallizing point corresponds to the highest of the first five consecutive readings (corrected as in 5.3) during which the temperature remains constant within 0,05 °C.

If supercooling occurs, as shown by a rise in temperature, observe the constant temperature after the rise. A temperature rise of 1 °C is the maximum allowable. If a constant temperature is not obtained over the first five readings after the rise in temperature, record six readings commencing with the point at which the maximum temperature is first attained.

Plot the complete cooling curve of temperature against time and draw a straight line to lie evenly between the first and second and between the fifth and sixth points mentioned above. Extend this line to meet the section of the cooling curve before the temperature rise.

Record the temperature (corrected as in 5.3) corresponding to the point of intersection, as the crystallizing point.

**5.3 Temperature correction**

Correct the temperatures by applying the correction for thermometer error.

**6 Expression of results**

The crystallizing point is the temperature determined in 5.3, rounded to the nearest 0,1 °C, reporting whether the sample is tested in the undried or dried condition.

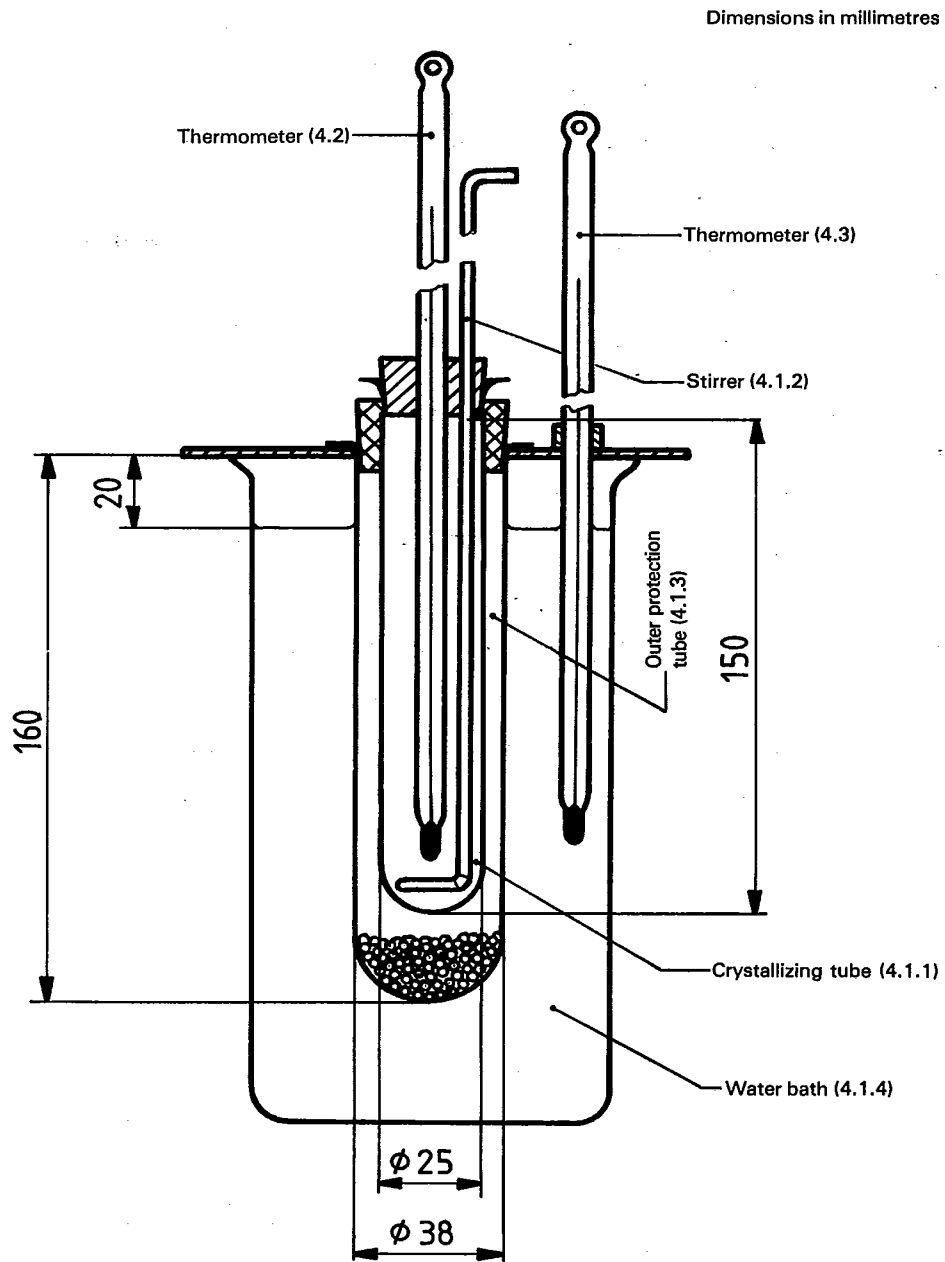

Figure — Apparatus for determination of crystallizing point

## Annex

ISO Publications relating to (A) phenol, (B) *o*-cresol, (C) *m*-cresol, (D) *p*-cresol, (E) cresylic acid, and (F) xylenols, for industrial use

Applicability						
A <sup>1)</sup>	B <sup>2)</sup>	C	D <sup>2)</sup>	E	F	ISO 1897/1 — General.
A	B	C	D	E	F	ISO 1897/2 — Determination of water — Dean and Stark method.
A	B	C	D	E	F	ISO 1897/3 — Determination of neutral oils and pyridine bases.
A	B	C	D			ISO 1897/4 — Visual test for impurities insoluble in sodium hydroxide solution.
A						ISO 1897/5 — Visual test for impurities insoluble in water.
				E	F	ISO 1897/6 — Test for absence of hydrogen sulphide.
				E	F	ISO 1897/7 — Measurement of colour.
				E	F	ISO 1897/8 — Determination of <i>o</i> -cresol content.
				E		ISO 1897/9 — Determination of <i>m</i> -cresol content.
A	B	C	D			ISO 1897/10 — Determination of dry residue after evaporation on a water bath.
A	B	C	D			ISO 1897/11 — Determination of crystallizing point.
				E	F	ISO 1897/12 — Determination of distillation range.
				E	F	ISO 1897/13 — Determination of residue on distillation.
A <sup>3)</sup>						ISO 1904 — Determination of phenols content — Bromination method.
A	B	C	D			ISO 2208 — Determination of crystallizing point after drying with a molecular sieve.

1) In the case of phenol, the determination of density at 20 °C specified in ISO 1897/1 is applicable only to liquefied phenol.

2) The determination of density at 20 °C specified in ISO 1897/1 is not applicable to these products.

3) Applicable only to liquefied phenol.