

---

# International Standard



# 1835

---

INTERNATIONAL ORGANIZATION FOR STANDARDIZATION • МЕЖДУНАРОДНАЯ ОРГАНИЗАЦИЯ ПО СТАНДАРТИЗАЦИИ • ORGANISATION INTERNATIONALE DE NORMALISATION

---

ANSI Internat Doc Sect

## Short link chain for lifting purposes — Grade M (4), non-calibrated, for chain slings etc.

*Chaînes de levage à maillons courts, classe M (4), non calibrées, pour élingues à chaînes, etc.*

First edition — 1980-09-15

SEP 19 1980

---

UDC 621.86.065.4

Ref. No. ISO 1835-1980 (E)

**Descriptors** : chains, hoisting slings, welded link chains, links of chain, materials specifications, dimensions, dimensional tolerances, tests, mechanical properties, tensile strength.

Price based on 8 pages

## FOREWORD

ISO (the International Organization for Standardization) is a worldwide federation of national standards institutes (ISO member bodies). The work of developing International Standards is carried out through ISO technical committees. Every member body interested in a subject for which a technical committee has been set up has the right to be represented on that committee. International organizations, governmental and non-governmental, in liaison with ISO, also take part in the work.

Draft International Standards adopted by the technical committees are circulated to the member bodies for approval before their acceptance as International Standards by the ISO Council.

International Standard ISO 1835 was developed by Technical Committee ISO/TC 111, *Round steel link chains, chain wheels, lifting hooks and accessories*, and was circulated to the member bodies in March 1978.

It has been approved by the member bodies of the following countries :

Australia	Ireland	South Africa, Rep. of
Austria	Italy	Sweden
Canada	Japan	Turkey
Chile	Korea, Rep. of	United Kingdom
Czechoslovakia	Mexico	USA
Denmark	Netherlands	USSR
India	Poland	Yugoslavia

The member bodies of the following countries expressed disapproval of the document on technical grounds :

Belgium  
France  
Germany, F.R.

This International Standard cancels and replaces ISO Recommendation R 1835-1971, of which it constitutes a technical revision.

# Short link chain for lifting purposes — Grade M (4), non-calibrated, for chain slings etc.

## 1 SCOPE AND FIELD OF APPLICATION

This International Standard specifies the requirements for lifting chains, grade M (4), non-calibrated, for use on cranes, in chain slings and for general lifting purposes. These are electrically welded round steel short link chains fully heat treated and tested and comply with the general conditions of acceptance of ISO 1834.

The range of sizes covered by this International Standard is from 5 to 45 mm. The annex gives a range of temporary additional sizes 6 to 46 mm.

## 2 REFERENCES

ISO/R 388, *ISO metric series for basic thicknesses of sheet and diameters of wire.*

ISO/R 643, *Micrographic determination of the austenitic grain size of steels.*

ISO 1035/1, *Dimensions of hot rolled steel bars — Part 1: Round bars — Metric series.*<sup>1)</sup>

ISO 1834, *Short link chain for lifting purposes — General conditions of acceptance.*

## 3 DEFINITIONS

For the purpose of this International Standard the definitions given in ISO 1834 apply.

## 4 GENERAL CONDITIONS OF ACCEPTANCE

The chain shall comply fully with the requirements of ISO 1834 as well as those of this International Standard.

## 5 DIMENSIONS

### 5.1 Size (see ISO 1834, clause 4, Definitions)

The size of chain shall be one of the sizes listed in table 1, column 1 corresponding to the nominal diameter ( $d_n$ ) of the steel wire (ISO/R 388) or bar (ISO 1035/1) from which the chain is made.

NOTE — Control over the size of the material (bar or wire) from

which the chain is made is important but this International Standard concerns finished chain and must assume that the inspector may not have the opportunity of retrospective measurement of the original material. The chain manufacturer will realize the need for the size of this material to be kept within accepted tolerances.

### 5.2 Material diameter (see ISO 1834 for definition of material diameter and method of measurement)

#### 5.2.1 Tolerance on material diameter

For sizes up to 18 mm the diameter  $d$  of the material in the finished link shall nowhere differ from the nominal diameter by more than  $\pm \frac{2}{6}$  %, except at the weld.

For sizes 18 mm and over, the diameter  $d$  of the material in the finished link shall nowhere differ from the nominal diameter by more than  $\pm 5$  %, except at the weld.

#### 5.2.2 Tolerances at the weld

The dimension of the steel at the weld shall nowhere be less than the diameter  $d$  of the steel adjacent to the weld, or exceed it by more than the following tolerances. (See figure 1 and table 1.)

Type 1 : 10 % of the nominal diameter in any direction;

Type 2 : 20 % of the nominal diameter in the direction perpendicular to the plane of the link and 20 % in other planes;

Type 3 : 20 % of the nominal diameter in the direction perpendicular to the plane of the link and 35 % in other planes.

NOTE — Type 1 eliminates functional problems such as kinking or locking by severely limiting the weld oversize to 10 % of the nominal diameter. Both types 2 and 3 ensure freedom from these hazards by limiting the oversize beyond the 10 % allowed under type 1 to certain areas of the link only (see figure 1) thus providing clearance where required.

#### 5.2.3 Area affected dimensionally by welding

The area affected dimensionally by welding shall not extend by more than 0,6 of the material to either side of the centre of the link.

1) At present at the stage of draft (Revision of ISO/R 1035/1-1969.)

### 5.3 Length and width

The dimensions of the length and width of the links shall be as specified in table 1 and illustrated in figure 2.

## 6 MATERIAL AND MANUFACTURE

### 6.1 Quality of material

The steel used shall be produced by the open hearth or electric process or by oxygen blown process.

In its finished state as supplied to the chain maker, the steel shall meet the following requirements as determined by check analysis on the rod, wire or finished link.

It shall be fully killed, shall possess reliable welding quality and when heat treated, be capable of producing in the finished chain the mechanical properties required by this specification.

Its content of sulphur and phosphorus shall be restricted as follows :

	Cast analysis	Check analysis
Sulphur, max.	0,045 %	0,050 %
Phosphorus, max.	0,040 %	0,045 %

The steel shall be made in conformity with a suitable deoxidization practice to obtain an austenitic grain size of 5 or finer when tested in accordance with ISO/R 643.

This could be accomplished, for example, by ensuring that it contains sufficient aluminium or an equivalent element to permit the manufacture of chain stabilized against strain age embrittlement during service; a minimum value of 0,02 % metallic aluminium is given for guidance.

Within the above limitations it is the responsibility of the chain maker to select steel so that the finished chain, suitably heat treated, meets the mechanical properties specified in this International Standard.

### 6.2 Heat treatment

All chain shall be normalized or hardened and tempered before being subjected to the proof force.

### 6.3 Proof force

The proof force shall be as specified in table 3, column 2 or table 5, column 2, and shall be applied as specified in ISO 1834.

## 7 TEST REQUIREMENTS

### 7.1 Mechanical properties and test forces

The mechanical properties shall be as specified in table 2, and the test forces to be applied for each size are specified in table 3 and table 5.

### 7.2 Selection of samples

Samples shall be selected as specified in ISO 1834. The length of the lot from which the inspector selects the samples shall be 200 m or lesser length.

### 7.3 Static tensile test

#### 7.3.1 Testing machine and method

The testing machine and method of testing shall be as specified in ISO 1834.

#### 7.3.2 Tensile test

The breaking force shall be not less than that specified in table 3, column 3, or table 5, column 3.

#### 7.3.3 Total ultimate elongation

The total ultimate elongation as defined in ISO 1834 shall be not less than 20 %.

## 8 INSPECTION

### 8.1 Provision for inspection

The provision for inspection shall be as specified in ISO 1834.

### 8.2 Acceptance

The acceptance procedure shall be as specified in ISO 1834.

## 9 MARKING

### 9.1 Quality marking

The quality mark for the chain is M or 4. It shall be applied as specified in ISO 1834.

### 9.2 Identification marking

The identification marking shall be as specified in ISO 1834.

### 9.3 Inspection marking

The inspection marking shall be as specified in ISO 1834.

## 10 TEST CERTIFICATE

The manufacturer shall if required supply a certificate of test and examination with every supply of chain containing the information detailed in ISO 1834. A typical form is given in ISO 1834, annex C.

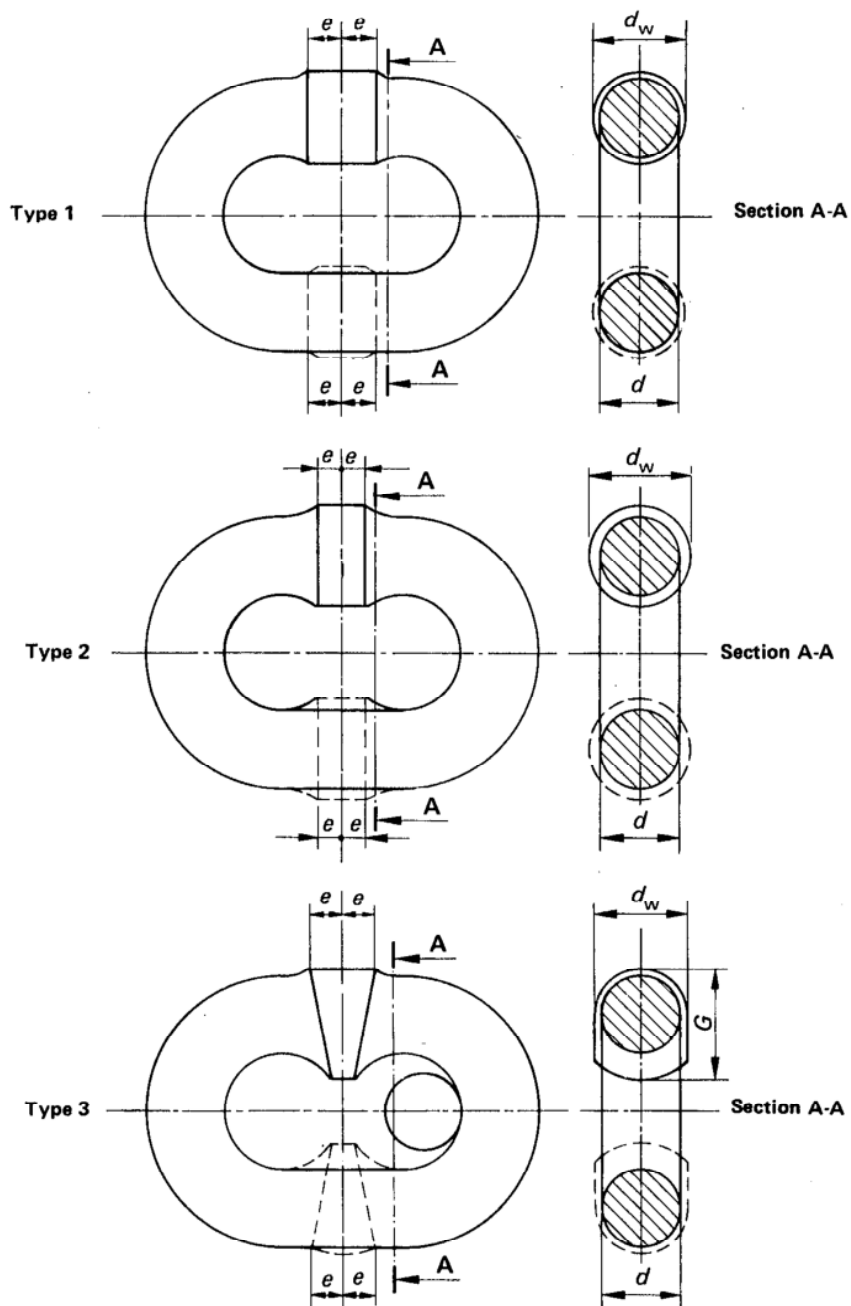

$d_n$  = size (nominal diameter of the material)

$d$  = measured diameter of the material except at the weld

$d_w$  = measured diameter of the material at the weld (type 1 and 2 welded chain) or weld dimension perpendicular to the plane of the link (type 3 welded chain)

$G$  = dimension in other planes (type 3 welded chain)

$e$  = length affected by welding on either side of the centre of the link

For all welds

$$e \leq 0,6 d_n$$

$$\text{For } d_n < 18 \text{ mm, } d = d_n + \frac{2}{6} \%$$

$$\text{For } d_n \geq 18 \text{ mm, } d = d_n \pm 5 \%$$

Weld tolerance :

$$\text{Type 1 : } d_w = d + \begin{matrix} 0,10 d_n \\ 0 \end{matrix}$$

$$\text{Type 2 : } d_w = d + \begin{matrix} 0,20 d_n \\ 0 \end{matrix}$$

$$\text{Type 3 : } d_w = d + \begin{matrix} 0,20 d_n \\ 0 \end{matrix}$$

$$G = d + \begin{matrix} 0,35 d_n \\ 0 \end{matrix}$$

Figure 1 – Material and weld tolerances

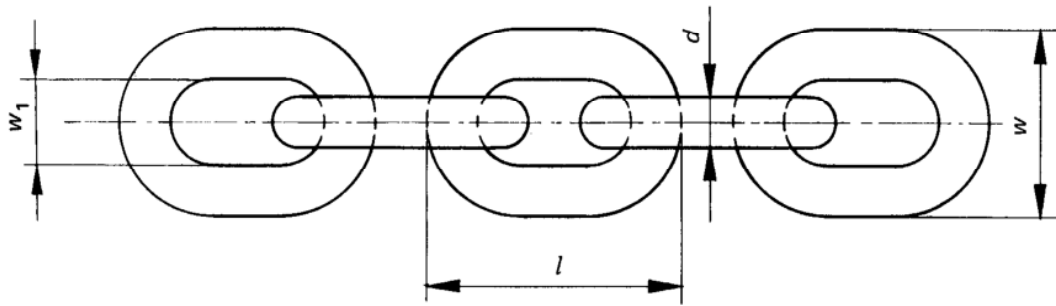

- $l$  = outside link length ( $4,75 d_n$  min.,  $5 d_n$  max.)  
 $w$  = outside link width ( $3,5 d_n$  max., except at weld)  
 $w_1$  = inside link width ( $1,25 d_n$  min., except at weld)

Figure 2 – Chain and link dimensions

**Table 1 — Dimensions of grade M (4) non-calibrated chain**  
(for symbols, see figures 1 and 2)

Dimensions in millimetres

(1)	(2)	(3)	(4)	(5)	(6)	(7)	(8)	(9)
Nominal size $d_n$	Diameter tolerance $(d - d_n)$	Maximum tolerance at the weld (see figure 1)			Outside link length limits		Outside link width away from weld $w_{max.}$ ( $3,5 d_n$ )	Minimum inside link width away from weld $w_1$ ( $1,25 d_n$ )
		Type 1 $(d_w - d)$	Type 2 and 3 $(d_w - d)$	Type 3 $(G - d)$	max. ( $5 d_n$ )	min. ( $4,75 d_n$ )		
5	+ 0,10 - 0,30	0,5	1,0	1,75	25	24	18	6,3
6,3	+ 0,13 - 0,38	0,63	1,26	2,2	32	30	22	7,9
7,1	+ 0,14 - 0,43	0,71	1,42	2,5	36	34	25	8,9
8	+ 0,16 - 0,48	0,8	1,6	2,8	40	38	28	10
9	+ 0,18 - 0,54	0,9	1,8	3,15	45	43	32	11,3
10	+ 0,20 - 0,60	1,0	2,0	3,5	50	47	35	12,5
11,2	+ 0,22 - 0,67	1,12	2,24	3,9	56	53	39	14
12,5	+ 0,25 - 0,75	1,25	2,5	4,4	63	59	44	15,7
14	+ 0,28 - 0,84	1,4	2,8	4,9	70	66	49	18
16	+ 0,32 - 0,96	1,6	3,2	5,6	80	76	56	20
18	± 0,90	1,8	3,6	6,3	90	85	63	23
20	± 1,0	2,0	4,0	7,0	100	95	70	25
22,4	± 1,1	2,24	4,48	7,85	112	106	78	28
25	± 1,25	2,5	5,0	8,75	125	119	88	32
28	± 1,4	2,8	5,6	9,8	140	133	98	35
32	± 1,6	3,2	6,4	11,2	160	152	112	40
36	± 1,8	3,6	7,2	12,6	180	171	126	45
40	± 2,0	4,0	8,0	14,0	200	190	140	50
45	± 2,25	4,5	9,0	15,75	225	214	158	57

NOTE — See annex for temporary additional sizes.

**Table 2 – Mechanical properties**

Mechanical property	Requirement
Mean stress at specified minimum breaking force $\frac{2F_m \text{ min.}}{\pi d_n^2}$	400 MPa (N/mm <sup>2</sup> )
Mean stress at proof force $\frac{2F_e}{\pi d_n^2}$	200 MPa (N/mm <sup>2</sup> )
Ratio of proof force to specified minimum breaking force	50 %
Specified minimum total ultimate elongation	20 %
Mean stress at working load limit	100 MPa (N/mm <sup>2</sup> )

**NOTES**

- 1 The stresses quoted in table 2 are obtained by dividing the force by the total cross-section of both sides of the link i.e. they are mean stresses. The stress is in fact not uniform and particularly at the extrados the maximum fibre stress is considerably greater.
- 2 The working load may be selected to comply with national regulations but it must in no case exceed the load in table 3, column 4, or table 5, column 4.

**Table 3 – Grade M (4), non-calibrated, test requirements and working load limits**

(1)	(2)	(3)	(4)
Nominal size $d_n$ mm	Proof force to which the whole chain is subjected kN	Minimum breaking force kN	Working load limit t
5	7,9	15,8	0,4
6,3	12,5	25	0,63
7,1	15,9	31,8	0,8
8	20,2	40,4	1,0
9	25,5	51	1,25
10	31,5	63	1,6
11,2	39,5	79	2,0
12,5	49,1	98,2	2,5
14	63	126	3,2
16	81	162	4,0
18	102	204	5,0
20	126	252	6,3
22,4	158	316	8,0
25	197	394	10
28	247	494	12,5
32	322	644	16
36	408	816	20
40	503	1 006	25
45	637	1 274	32



## ANNEX

**TEMPORARY ADDITIONAL SIZES**  
 (Grade M (4) non-calibrated)

These sizes have been added as a temporary measure as an aid to chain selection until the standard sizes (table 1) are in general international use.

**Table 4 – Dimensions**  
 (for symbols see figures 1 and 2)

Dimensions in millimetres

(1)	(2)	(3)	(4)	(5)	(6)	(7)	(8)	(9)
Nominal size $d_n$	Diameter tolerance $(d - d_n)$	Maximum tolerance at the weld (see figure 1)			Outside link length limits		Outside link width away from weld $w_{max.}$ ( $3,5 d_n$ )	Minimum inside link width away from weld $w_1$ ( $1,25 d_n$ )
		Type 1 $(d_w - d)$	Type 2 and 3 $(d_w - d)$	Type 3 $(G - d)$	max. ( $5 d_n$ )	min. ( $4,75 d_n$ )		
6	+ 0,12 - 0,36	0,6	1,2	2,1	30	28	21	7,5
7	+ 0,14 - 0,42	0,7	1,4	2,45	35	33	25	8,8
8,7	+ 0,17 - 0,52	0,87	1,74	3,05	44	41	30	10,9
9,5	+ 0,19 - 0,57	0,95	1,9	3,35	48	45	33	11,9
10,3	+ 0,21 - 0,62	1,03	2,06	3,6	52	49	36	12,9
11	+ 0,22 - 0,66	1,1	2,2	3,85	55	52	39	13,8
12	+ 0,24 - 0,72	1,2	2,4	4,2	60	57	42	15,0
13	+ 0,26 - 0,78	1,3	2,6	4,55	65	62	46	16,3
13,5	+ 0,27 - 0,81	1,35	2,7	4,75	68	64	47	17
16,7	+ 0,33 - 1,0	1,67	3,34	5,85	84	79	58	21
19	± 0,95	1,9	3,8	6,65	95	90	67	24
20,6	± 1,0	2,06	4,1	7,2	103	98	72	26
25,4	± 1,3	2,54	5,1	8,9	127	121	89	32
30	± 1,5	3,0	6,0	10,5	150	142	105	38
41,3	± 2,1	4,13	8,26	14,45	207	196	145	52
46	± 2,3	4,6	9,2	16,1	230	218	161	58

NOTE – The measurements given in column 9 are made away from the weld, but type 1 welded chains customarily meet the requirement at the weld also.

**Table 5 — Test requirements and working load limits,  
Grade M (4) non-calibrated chain shown in table 4  
(temporary additional sizes)**

(1)	(2)	(3)	(4)
Nominal size $d_n$ mm	Proof force to which the whole chain is subjected kN	Minimum breaking force kN	Working load limit t
6	11,4	22,8	0,57
7	15,4	30,8	0,78
8,7	23,8	47,6	1,2
9,5	28,4	56,8	1,4
10,3	33,4	66,8	1,7
11	38,1	76,2	1,9
12	45,3	90,6	2,3
13	54	108	2,7
13,5	58	116	2,9
16,7	88	176	4,4
19	114	228	5,7
20,6	134	268	6,8
25,4	203	406	10,3
30	283	566	14,4
41,3	536	1 072	27,3
46	665	1 330	33,9