Belt drives — V-ribbed belts, joined V-belts and V-belts including wide section belts and hexagonal belts — Electrical conductivity of antistatic belts: Characteristics and methods of test

Transmissions par courroies — Courroies striées, courroies trapézoïdales simples et jumelées y compris celles à section large et hexagonales — Conductibilité électrique des courroies anti-électrostatiques: Spécifications et méthodes d'essai





COPYRIGHT PROTECTED DOCUMENT

© ISO 2014

All rights reserved. Unless otherwise specified, no part of this publication may be reproduced or utilized otherwise in any form or by any means, electronic or mechanical, including photocopying, or posting on the internet or an intranet, without prior written permission. Permission can be requested from either ISO at the address below or ISO's member body in the country of the requester.

ISO copyright office
Case postale 56 • CH-1211 Geneva 20
Tel. + 41 22 749 01 11
Fax + 41 22 749 09 47
E-mail copyright@iso.org
Web www.iso.org

Published in Switzerland

Contents

	Page
Foreword	iv
1 Scope	1
2 Normative references	1
3 Electrical conductivity characteristics	2
4 Principle	2
5 Test apparatus and material	2
6 Test piece	3
7 Production control test method (factory method)	3
7.1 Conditioning and test conditions	3
7.2 Test procedure	3
7.3 Number of tests	4
7.4 Belt electrical resistance criteria	4
8 Proof test method for individual belts (laboratory method)	4
8.1 Conditioning and test conditions	4
8.2 Electrical conductive coating	4
8.3 Preparation	4
8.4 Test procedure	5
8.5 Number of tests	5
8.6 Belt electrical resistance criteria	5
Annex A (informative) Movable electrode for testing single belts	12

Foreword

ISO (the International Organization for Standardization) is a worldwide federation of national standards bodies (ISO member bodies). The work of preparing International Standards is normally carried out through ISO technical committees. Each member body interested in a subject for which a technical committee has been established has the right to be represented on that committee. International organizations, governmental and non-governmental, in liaison with ISO, also take part in the work. ISO collaborates closely with the International Electrotechnical Commission (IEC) on all matters of electrotechnical standardization.

The procedures used to develop this document and those intended for its further maintenance are described in the ISO/IEC Directives, Part 1. In particular the different approval criteria needed for the different types of ISO documents should be noted. This document was drafted in accordance with the editorial rules of the ISO/IEC Directives, Part 2 (see www.iso.org/directives).

Attention is drawn to the possibility that some of the elements of this document may be the subject of patent rights. ISO shall not be held responsible for identifying any or all such patent rights. Details of any patent rights identified during the development of the document will be in the Introduction and/or on the ISO list of patent declarations received (see www.iso.org/patents).

Any trade name used in this document is information given for the convenience of users and does not constitute an endorsement.

For an explanation on the meaning of ISO specific terms and expressions related to conformity assessment, as well as information about ISO's adherence to the WTO principles in the Technical Barriers to Trade (TBT) see the following URL: [Foreword - Supplementary information](#)

The committee responsible for this document is ISO/TC 41, *Pulleys and belts (including veebelts)*, Subcommittee SC 1, *Friction*.

This fourth edition cancels and replaces the third edition (ISO 1813:1998), which has been technically revised.

Belt drives — V-ribbed belts, joined V-belts and V-belts including wide section belts and hexagonal belts — Electrical conductivity of antistatic belts: Characteristics and methods of test

1 Scope

This International Standard specifies the maximum electrical resistance of antistatic endless V-ribbed belts, joined V-belts, and single V-belts including wide section belts and hexagonal belts, as well as corresponding production control and individual proof methods of measurements.

The application of this International Standard is limited to new belts intended to be used in an explosive atmosphere or in situations where there is a fire risk. The test is intended to ensure that the belt is sufficiently conductive to dissipate charges of electricity which can form on it in service.

In case of a production control test, the decision is left to national standards or agreement between interested parties as to whether the test shall be carried out on each belt in a batch or on only a percentage of belts in a batch.

NOTE For each proof test, it is intended that the belt manufacturer determine which type of electrode and conductive coating material can be used.

2 Normative references

The following documents, in whole or in part, are normatively referenced in this document and are indispensable for its application. For dated references, only the edition cited applies. For undated references, the latest edition of the referenced document (including any amendments) applies.

ISO 1604, *Belt drives — Endless wide V-belts for industrial speed-changers and groove profiles for corresponding pulleys*

ISO 2790, *Belt drives — V-belts for the automotive industry and corresponding pulleys — Dimensions*

ISO 3410, *Agricultural machinery — Endless variable-speed V-belts and groove sections of corresponding pulleys*

ISO 4183, *Belt drives — Classical and narrow V-belts — Grooved pulleys (system based on datum width)*

ISO 4184, *Belt drives — Classical and narrow V-belts — Lengths in datum system*

ISO 5289, *Agricultural machinery — Endless hexagonal belts and groove sections of corresponding pulleys*

ISO 5290, *Belt drives — Grooved pulleys for joined narrow V-belts — Groove sections 9N/J, 15N/J and 25N/J (effective system)*

ISO 5291, *Belt drives — Grooved pulleys for joined classical V-belts — Groove sections AJ, BJ, CJ and DJ (effective system)*

ISO 9981, *Belt drives — Pulleys and V-ribbed belts for the automotive industry — PK profile: Dimensions*

ISO 9982, *Belt drives — Pulleys and V-ribbed belts for industrial applications — PH, PJ, PK, PL and PM profiles: dimensions*

ISO 23529, *Rubber — General procedures for preparing and conditioning test pieces for physical test methods*

3 Electrical conductivity characteristics

The electrical conductivity of an individual belt, when tested by the production control test method (factory test) in accordance with [Clause 7](#), shall have an electrical resistance not greater than that given by the appropriate limit value specified in [Table 1](#), [2](#), or [3](#).

The electrical conductivity of an individual belt, when proof-tested in accordance with [Clause 8](#), shall have an electrical resistance not greater than that given by Formula (1).

4 Principle

The electrical resistance along a fixed length of belt is measured by an insulation tester under specified conditions. The belt(s) is (are) accepted as suitable for antistatic duties if the electrical conductivity is sufficiently high that a specified level of electrical resistance is not exceeded.

5 Test apparatus and material

5.1 Insulation tester, with a nominal open-circuit voltage of 500 V d.c. capable of applying a voltage of not less than 40 V with a power of not more than 3 W in the belt section under test and capable of measuring the electrical resistance with an accuracy of $\pm 5\%$.

The voltage shall be applied no longer than is necessary to carry out the test, in order to reduce the risk of overheating the test piece.

For values of resistance above $10^6 \Omega$, an instrument with a nominal open-circuit voltage of 1 000 V may be used.

5.2 Metal electrodes

5.2.1 Two metal electrodes, of low electrical resistance, preferably brass, having contact surfaces of minimum width of 25 mm, arranged in a nominal distance of 100 mm apart on an electrically insulated base (see [Figure 1](#)).

5.2.2 Electrodes for testing single V-belts (driving surfaces). The dimensions of the V-groove of the fixed electrodes shall be as specified for the pulley groove profile associated with the belt. The groove angle shall be specified by the manufacturer according to the design and type of belt being tested (see [Figure 3](#)).

In order to maintain continuity with previous editions of this International Standard, the movable electrodes applicable to classical and narrow V-belts are retained as alternatives to the fixed electrodes. These electrodes have contact surfaces which are free to rotate around an axis parallel to the drive side surfaces of the belt (see [Figures 5](#) and [6](#) and [Table A.1](#)).

These types of electrodes are not applicable to V-ribbed belts or joined V-belts.

5.2.3 Electrodes for testing V-ribbed belts (driving surfaces).

5.2.3.1 Electrodes for testing the flank of the belt of V-ribbed belts (driving surfaces). The dimensions of the grooved electrode shall be as specified for the pulley groove profile associated with the belt (see [Figure 4](#)).

For V-ribbed belts with more than four ribs, it is necessary to move the belt so that the entire number of ribs are tested. If the material permits to test a higher number of ribs, it is not useful to move the belt.

NOTE The angle, α , is the same for the belt and the pulley.

5.2.3.2 Electrodes for testing the back of the belt of V-ribbed belts (driving surfaces). For the measurement on the back of the belt, the length, l , shall be considered equal to the pitch, P , multiplied by the number of ribs, in accordance with ISO 9981 or ISO 9982, as applicable.

EXAMPLE PK with six ribs

$$l = 3,56 \times 6 = 21,36 \text{ mm}$$

5.2.4 Electrodes for testing joined V-belts (driving surfaces). When testing the joined V-belt as a whole, the dimensions of the grooved electrodes shall be as specified for the pulley groove profile associated with the belt. The groove angle shall be specified by the manufacturer according to the design and type of belt being tested (see [Figure 4](#)).

When testing the individual belts comprising the joined V-belt, the electrodes shall consist of two V-grooves. The groove angle shall be specified by the manufacturer according to the design and type of belt being tested.

For joined V-belts with more than two strands, it is necessary to move the belt so that the entire belt is tested.

5.3 Belt loading, used as a means of applying a force of 1 N per millimetre nominal width of the belt to ensure adequate contact between the electrode and the belt shall be provided (see [Figure 1](#)). The force may be applied indirectly by a lever arm (see [Figure 2](#) for typical apparatus).

For joined V-belts inserted in an electrode arrangement, as shown in [Figure 4](#), the specified test force shall be applied on each single belt. The groove spacing is considered to be the belt top width.

For V-ribbed belts, the nominal width is equal to the pitch, P , multiplied by the number of ribs.

EXAMPLE PK with 6 ribs

$$\text{Width} = 3,56 \times 6 = 21,36 \text{ mm}$$

The load will be 21,36 N

6 Test piece

The test piece is a complete endless V-ribbed belt, joined V-belt, or single V-belt.

7 Production control test method (factory method)

7.1 Conditioning and test conditions

The test shall be carried out at ambient temperature between 15 °C and 30 °C with the product allowed to cool to within this temperature range before testing.

7.2 Test procedure

Straighten the belt between the electrodes. To ensure adequate electrical contact between the belt and the electrode, apply the force as given in [5.3](#).

Avoid breathing on the test surfaces as any condensation of moisture can falsify the result.

Measure the resistance in ohms, 5 s ± 1 s after applying the voltage.

7.3 Number of tests

For belts up to 2 000 mm in length, test as follows:

- test single V-belts at two points along the length of the belt;
- test hexagonal belts on both sets of driving surfaces at two points each along the length of the belt;
- for joined V-belts, when testing the belt as a whole, test at two points along the length of the belt; when testing each strand of belt within the joined V-belt, test each belt at two points along the length of the belt (see Note 1 to [Table 3](#));
- for V-ribbed belts, for standard widths up to and including 20 ribs, test each belt at two points along the length of the belt (see Note 1 to [Table 2](#)).

For longer belts, increase the number of test points by one for each increase in length of 1 000 mm or part thereof.

7.4 Belt electrical resistance criteria

None of the individual values obtained in [7.3](#) shall be greater than the values specified in [Tables 1, 2, and 3](#).

For marking belts, the electrical conductivity of belts shall fulfil the values given in [Tables 1, 2, and 3](#).

8 Proof test method for individual belts (laboratory method)

8.1 Conditioning and test conditions

The following treatments and the test shall be carried out in a standard atmosphere 23/50 in accordance with ISO 23529 at a temperature of (23 ± 2) °C and (50 ± 5) % relative humidity.

8.2 Electrical conductive coating

To ensure minimum electrical resistance between the test metal electrodes and the test belt surfaces, a conductive coating shall be provided comprising either

- a) a conductive silver lacquer or colloidal graphite, which shall be of the type that dries at room temperature and the surface resistivity of the dried film shall be below $10 \Omega \cdot \text{m}$, or
- b) a conductive liquid consisting of
 - 800 parts of anhydrous polyethylene glycol of molecular mass 600,
 - 200 parts of water,
 - 1 part of wetting agent, and
 - 10 parts of potassium chloride.

In the latter case, the electrode contact areas shall be completely wetted and remain so until the end of the test.

8.3 Preparation

The belt shall be maintained in an unstrained state, for a period not less than 2 h in a standard atmosphere 23/50, in accordance with ISO 23529.

Immediately following this conditioning, clean the belt surfaces that are to be placed against the test electrodes by rubbing with dry Fuller's earth using a clean cloth.

After cleaning away all traces of the powder, wipe the surface with a cloth moistened with distilled water and rub dry with a clean dry cloth, while avoiding straining the test piece. Then, immediately apply the conductive coating material (see 8.2) on each of the belt/electrode contact areas for a length of 25 mm along the belt; these two zones shall be separated by a dry distance of 100 mm ± 6 mm.

8.4 Test procedure

The test shall be carried out in a place having a standard atmosphere 23/50, in accordance with ISO 23529.

Clean the electrodes. With the belt being in an unstrained state, apply the electrodes on the coated contact areas so only these surfaces of the belt are in contact.

The belt being tested shall not be deformed (flexed). To ensure adequate electrical contact between the belt and electrode, apply the force as detailed in 5.3.

Avoid breathing on the test surface as any condensation of moisture can falsify the result.

Measure the resistance in ohms, 5 s ± 1 s after applying the voltage. The voltage applied shall not be less than 40 V.

Measure the distance, L , between the contact areas of the belt and the sum, l , of the contact lengths of the face or faces of the belt.

8.5 Number of tests

Make at least five tests, spaced at regular intervals along the complete length of the belt.

NOTE If the belt is too short to carry out this minimum of five tests, the number of tests can be reduced accordingly.

8.6 Belt electrical resistance criteria

The specified maximum value belt electrical resistance, R , expressed in ohms, in Tables 1, 2, and 3, is derived from Formula (1):

$$R \leq 6 \times 10^5 \frac{L}{l} \quad (1)$$

where

L is the dry distance between the electrodes;

l is the total length of contact across the width of the belt with the electrode.

For example:

- a) narrow V-belt: sum of two equal flank lengths of the belt section;
- b) V-ribbed belts:
 - 1) on ribs: sum of the measured flank contact lengths per rib multiplied by the number of ribs;
 - 2) on back: pitch, P , multiplied by the number of ribs;
- c) back of a joined V-belt: width of electrode or width of belt, whichever is the lesser;
- d) joined V-belts: sum of two equal flank lengths of the belt section multiplied by the number of belts.

None of the individual values obtained in 8.5 shall be greater than the specified value.

Table 1 — Limit values of electrical resistance when testing the driving surfaces of single V-belts including hexagonal belts

Maximum resistance MΩ	Industrial V-belt			Automotive V-belt	Agricultural belt	
	Classical ISO 4183 ISO 4184	Narrow ISO 4183 ISO 4184	Wide ISO 1604	Narrow ISO 2790	Wide ISO 3410	Hexagonal ISO 5289
8 7,1 6,3	Y					
5,6 5 4,48	Z		W 16			HAA HBB
4 3,6 3,2	A	SPZ	W 20 W 25	AV 10	HG	HCC
2,8 2,5 2,24	B	SPA	W 31,5 W 40	AV 13	HH HI	HDD
2 1,8 1,6	C	SPB SPC	W 50		HJ HK	
1,42 1,26 1,2	D		W 63		HL HM HN	
1,12 1 0,9	E		W 80 W 100		HO	

NOTE 1 Distance between the contact areas: $L = 100$ mm.
 NOTE 2 Electrode configuration: see [Figures 3, 4, 5, and 6](#).

Table 2 — Limit values of electrical resistance when testing the driving surfaces of V-ribbed belts

Number of ribs ^a	Maximum resistance MΩ				
	ISO 9981 and ISO 9982 V-ribbed belts profile				
	PH	PJ	PK	PL	PM
3	9	5,6	3,2	2,1	1,1
4	6,7	4,14	2,5	1,6	0,8
5	5,4	3,3	2	1,3	0,64
6	4,5	2,8	1,6	1,1	0,53
7	3,9	2,4	1,4	0,9	0,46
8	3,4	2	1,3	0,8	0,4
9	3	1,9	1,1	0,7	0,35
10	2,7	1,7	1	0,6	0,33

NOTE 1 Distance between the contact areas: $L = 100$ mm.

NOTE 2 Electrode configuration: see [Figure 4](#).

^a For V-ribbed belts with greater than four ribs, it is necessary to move the belt so that all ribs are tested.

Table 3 — Limit values of electrical resistance when testing the driving surfaces of joined V-belts

Number of strands in band ^a	Maximum resistance MΩ							
	Narrow ISO 5290				Classical ISO 5291			
	9J	15J	20J	25J	AJ	BJ	CJ	DJ
2	1,8	1,26	1	0,8	1,8	1,26	1	0,71

NOTE 1 Distance between the contact areas: $L = 100$ mm.

NOTE 2 Electrode configuration: see [Figure 4](#).

^a For joined V-belts with greater than two strands, it is necessary to move the belt so that the entire belt is tested.

Table 4 — Limit value of electrical resistance when testing the back surface of V-ribbed belts

Number of ribs	Back maximum resistance MΩ				
	ISO 9981 and ISO 9982 V-ribbed belts profile				
	PH	PJ	PK	PL	PM
3	12,5	8,5	5,6	4,3	2,1
4	9,4	6,4	4,2	3,2	1,6
5	7,5	5,1	3,4	2,6	1,3
6	6,3	4,3	2,8	2,1	1,1
7	5,4	3,7	2,4	1,8	0,9
8	4,7	3,2	2,1	1,6	0,8
9	4,2	2,9	1,9	1,4	0,7
10	3,7	2,6	1,7	1,3	0,6

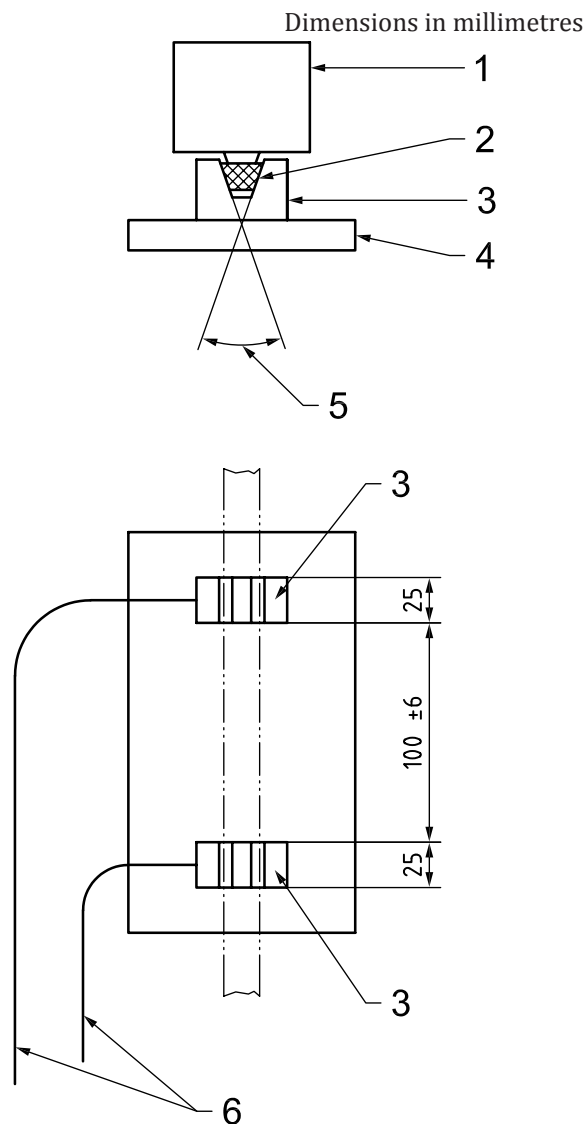

Key

- 1 suitable mass which exerts at each metal contact a force of 1 N/mm of the top width of the belt
- 2 belt
- 3 metal contact
- 4 insulating base
- 5 angle to suit belt
- 6 insulated leads to insulation test meter

Figure 1 — Apparatus for measuring the electrical resistance of belts

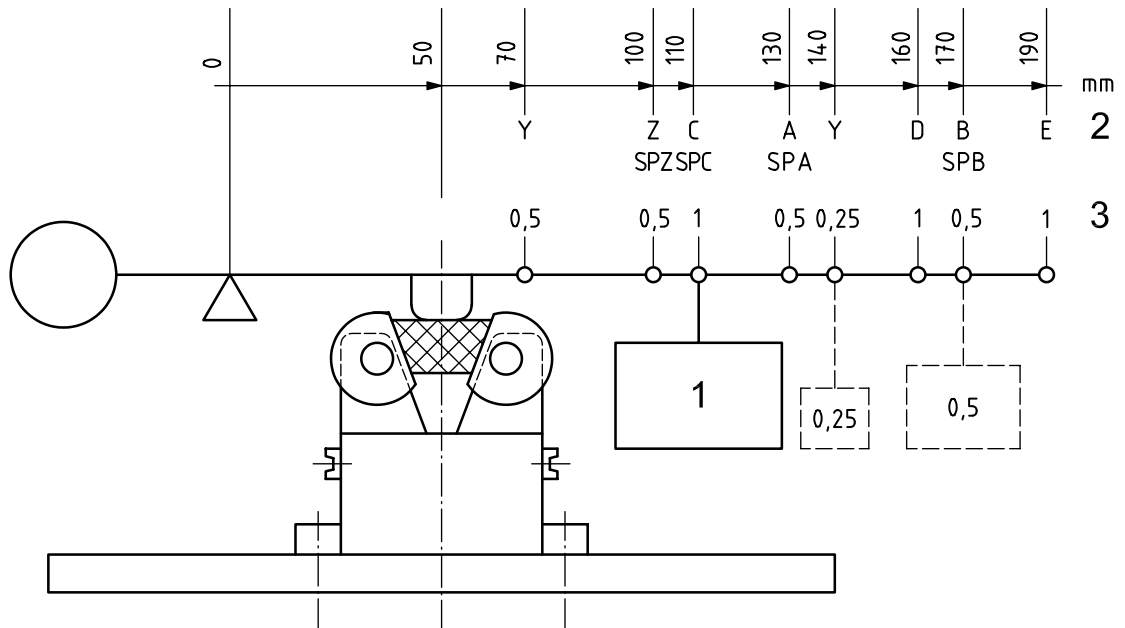

Key

- 1 mass
- 2 profile
- 3 force, in decanewtons (daN)

Figure 2 — Loading apparatus (example)

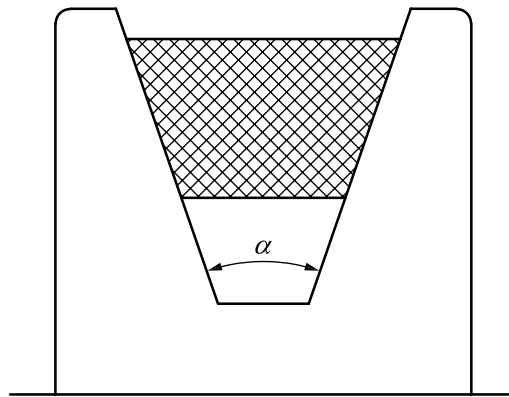
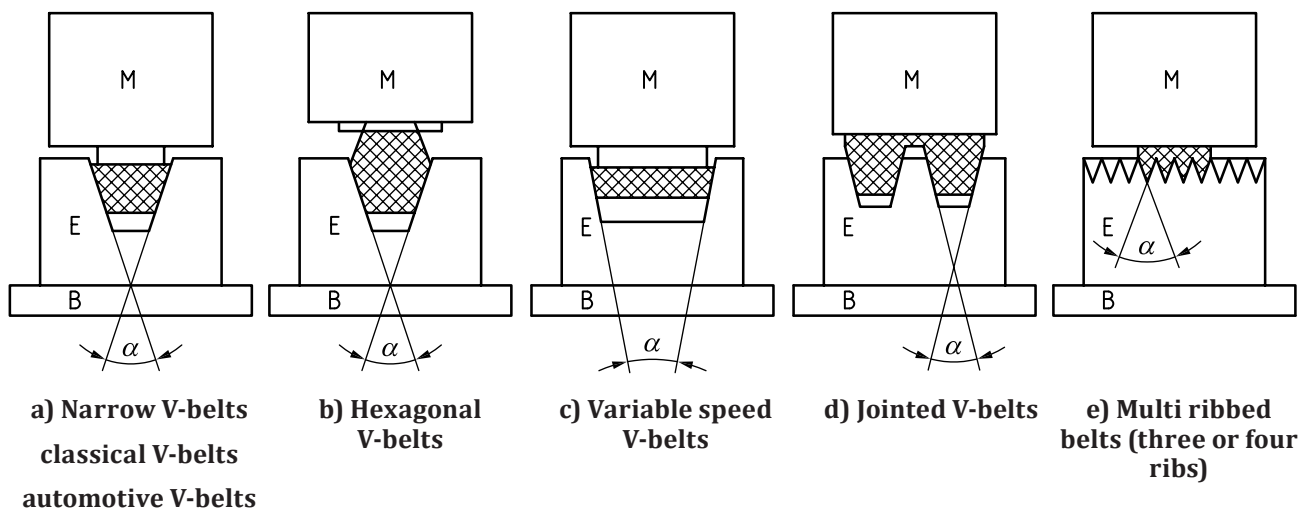

Figure 3 — Fixed electrode for testing single belts



Key

B insulating base

E electrode

M suitable mass which exerts at each metal contact a force of 1 N/mm of the top width of belt

Figure 4 — Electrode configurations for measuring the electrical resistance of belts

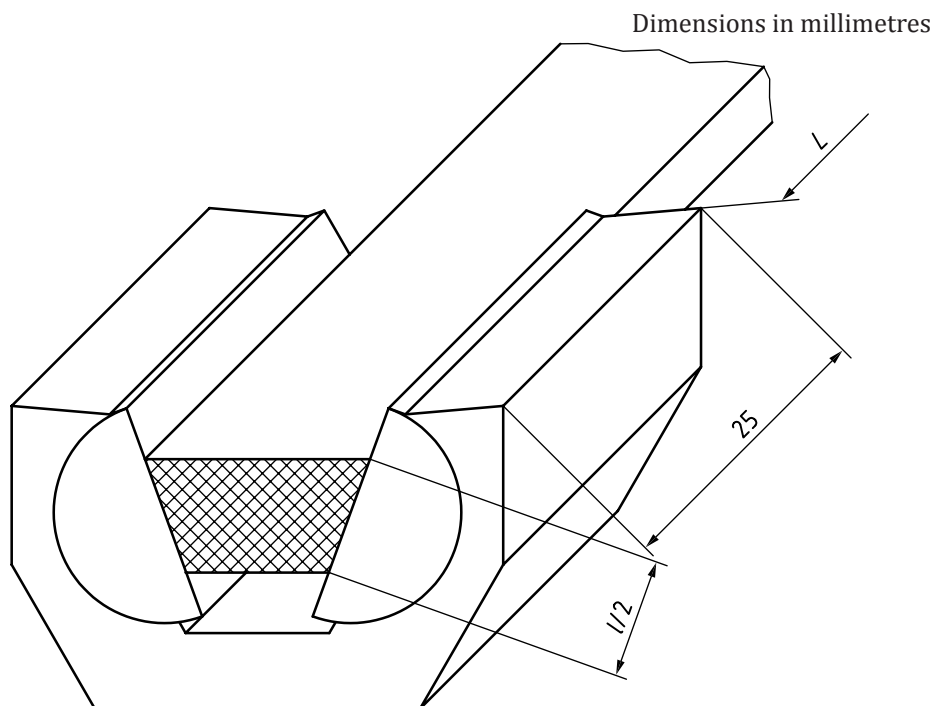

Figure 5 — Movable electrode for testing single belts (schematic diagram)

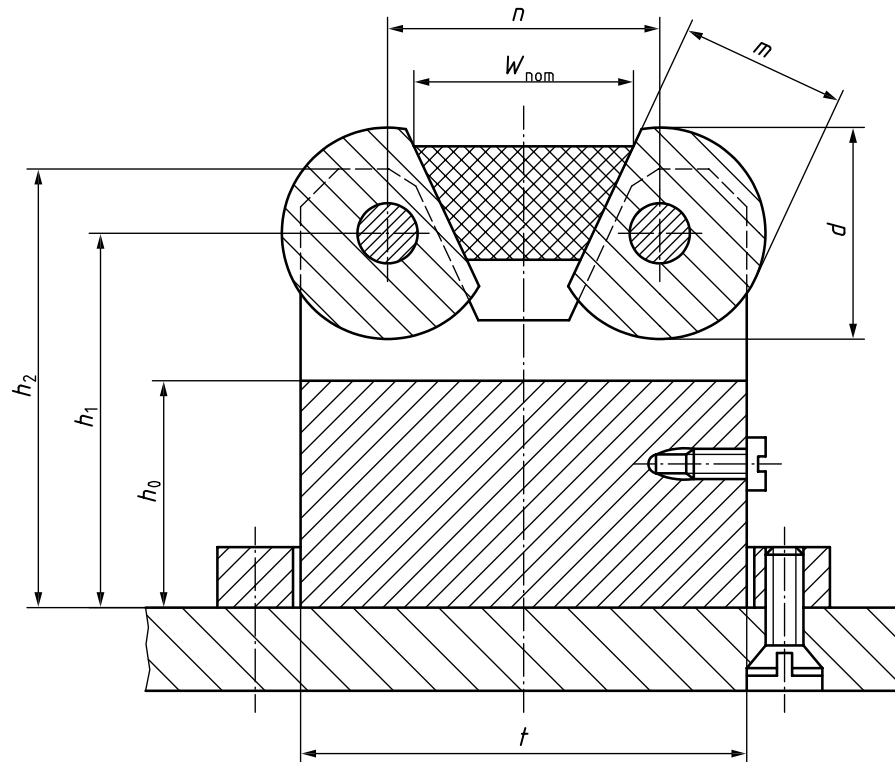

Figure 6 — Movable electrode for testing single belts (example)

Copyright International Organization for Standardization

Annex A (informative)

Movable electrode for testing single belts

Example in accordance with [Figures 3](#) and [6](#).

Table A.1 — Recommended dimensions

Dimensions in millimetres

Profile	w_{nom}	d	m	n
ISO 4183 and ISO 4184 classical V-belts				
Y	6	16	15	18
Z	10	20	18	23
A	13	20	18	25
B	17	25	20	27
C	22	25	20	31
D	32	31,5	25	42
E	40	40	30	50
ISO 4183 and ISO 4184 narrow V-belts				
SPZ	10	20	18	22
SPA	13	20	18	24
SPB	17	25	20	26
SPC	22	25	20	29

.....

ICS 21.220.10

Price based on 12 pages