**Dentistry — Shanks for rotary
instruments —**

**Part 3:
Shanks made of ceramics**

*Médecine bucco-dentaire — Queues pour instruments rotatifs —
Partie 3: Queues en céramique*



Reference number
ISO 1797-3:2013(E)



COPYRIGHT PROTECTED DOCUMENT

© ISO 2013

All rights reserved. Unless otherwise specified, no part of this publication may be reproduced or utilized otherwise in any form or by any means, electronic or mechanical, including photocopying, or posting on the internet or an intranet, without prior written permission. Permission can be requested from either ISO at the address below or ISO's member body in the country of the requester.

ISO copyright office
Case postale 56 • CH-1211 Geneva 20
Tel. + 41 22 749 01 11
Fax + 41 22 749 09 47
E-mail copyright@iso.org
Web www.iso.org

Published in Switzerland

Contents		Page
Foreword		iv
1 Scope		1
2 Normative references		1
3 Terms, definitions and symbols		1
3.1 Terms and definitions		1
3.2 Symbols and terms		2
4 Classification		2
5 Requirements		3
5.1 Material		3
5.2 Dimensions		3
5.3 Shank cylindricity		5
5.4 Surface roughness		5
5.5 Vickers hardness		5
5.6 Marking		5
6 Test methods		6
6.1 Shank diameter		6
6.2 Other dimensions		6
6.3 Shank cylindricity		6
6.4 Surface roughness		6
6.5 Vickers hardness		6
7 Quality control		6
7.1 Types of shank		6
7.2 Defects		6
Annex A (informative) Acceptable quality levels (AQL)		7
Bibliography		8

Foreword

ISO (the International Organization for Standardization) is a worldwide federation of national standards bodies (ISO member bodies). The work of preparing International Standards is normally carried out through ISO technical committees. Each member body interested in a subject for which a technical committee has been established has the right to be represented on that committee. International organizations, governmental and non-governmental, in liaison with ISO, also take part in the work. ISO collaborates closely with the International Electrotechnical Commission (IEC) on all matters of electrotechnical standardization.

International Standards are drafted in accordance with the rules given in the ISO/IEC Directives, Part 2.

The main task of technical committees is to prepare International Standards. Draft International Standards adopted by the technical committees are circulated to the member bodies for voting. Publication as an International Standard requires approval by at least 75 % of the member bodies casting a vote.

Attention is drawn to the possibility that some of the elements of this document may be the subject of patent rights. ISO shall not be held responsible for identifying any or all such patent rights.

ISO 1797-3 was prepared by Technical Committee ISO/TC 106, *Dentistry*, Subcommittee SC 4, *Dental instruments*.

ISO 1797 consists of the following parts, under the general title *Dentistry — Shanks for rotary instruments*:

- *Part 1: Shanks made of metals*
- *Part 2: Shanks made of plastics*
- *Part 3: Shanks made of ceramics*

Dentistry — Shanks for rotary instruments —

Part 3: Shanks made of ceramics

1 Scope

This part of ISO 1797 specifies ceramic shanks of rotary instruments used in dentistry and gives measurement methods for the verification of the dimensions.

2 Normative references

The following documents, in whole or in part, are normatively referenced in this document and are indispensable for its application. For dated references, only the edition cited applies. For undated references, the latest edition of the referenced document (including any amendments) applies.

ISO 1942, *Dentistry — Vocabulary*

ISO 3274, *Geometrical Product Specifications (GPS) — Surface texture: Profile method — Nominal characteristics of contact (stylus) instruments*

ISO 4288, *Geometrical Product Specifications (GPS) — Surface texture: Profile method — Rules and procedures for the assessment of surface texture*

ISO 6507-1, *Metallic materials — Vickers hardness test — Part 1: Test method*

ISO 8325, *Dentistry — Test methods for rotary instruments*

3 Terms, definitions and symbols

3.1 Terms and definitions

For the purposes of this document, the terms and definitions given in ISO 1942 and the following apply.

3.1.1 shank

part of the shaft of a rotary instrument used in dentistry which is designed to fit into the chuck of a straight or contra-angle dental handpiece, a technical handpiece or a dental turbine

3.2 Symbols and terms

Symbols and terms are shown in [Figures 1 to 8](#) with the following key:

d_1	shank diameter;
d_2	diameter in the groove;
s	maximum distance from the circumference to the flat portion;
l_1	fitting length;
l_2	shoulder to end length;
l_3	shoulder to groove length;
l_4	width of groove;
l_5	length of conical or rounded end;
δ	shank cylindricity.

4 Classification

Shanks for rotary instruments are classified into the following types, according to their diameters and designs:

- Type 1: RA (right angle) - diameter 2,35 mm with groove and flat;
- Type 2: HP (handpiece) - diameter 2,35 mm cylindrical;
- Type 3: FG (friction grip) - diameter 1,6 mm cylindrical with conical or rounded end;
- Type 4: HP (handpiece) - diameter 3 mm cylindrical.

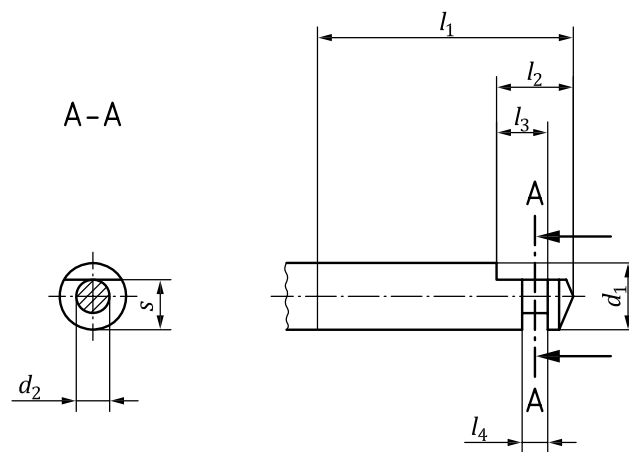

Figure 1 — Type 1 shank

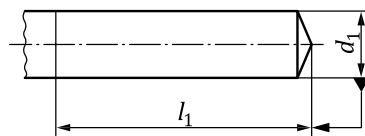

Figure 2 — Type 2 and Type 4 shank

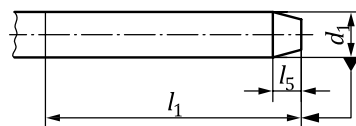

Figure 3 — Type 3 shank

5 Requirements

5.1 Material

Shanks shall be made of ceramic materials. The exact type of material and the treatment given to it are at the discretion of the manufacturer.

5.2 Dimensions

The dimensions and tolerances shall be as shown in [Figure 4](#) to [Figure 7](#) and as given in [Table 1](#).

Dimensions are given in millimetres, surface roughness in micrometres.

The end of the shank for Types 1, 2 and 4 shall be either flat, conical or rounded. The end of the shank for Type 3 shall be either conical or rounded.

The shape of the shank end shall be at the discretion of the manufacturer.

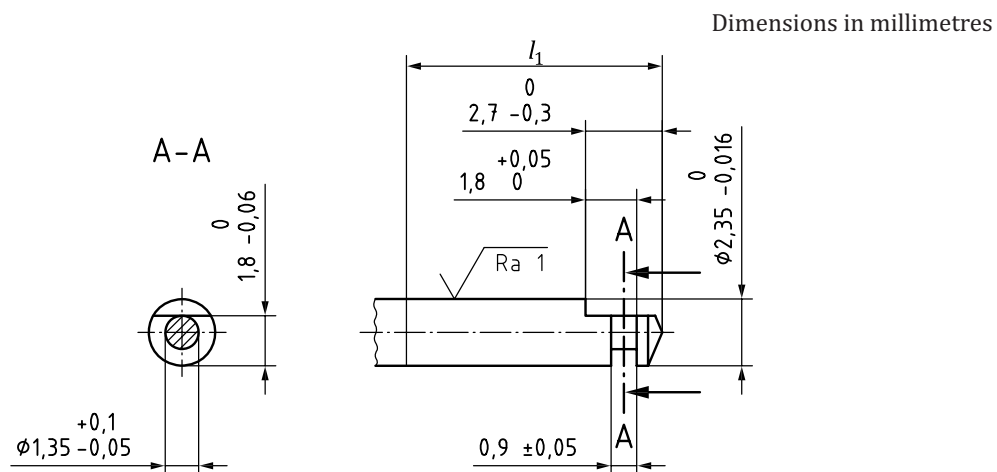

Figure 4 — Dimensions Type 1 shank

Dimensions in millimetres

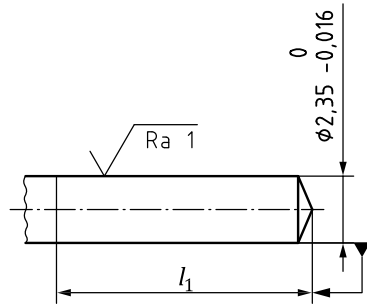

Figure 5 — Dimensions Type 2 shank

Dimensions in millimetres

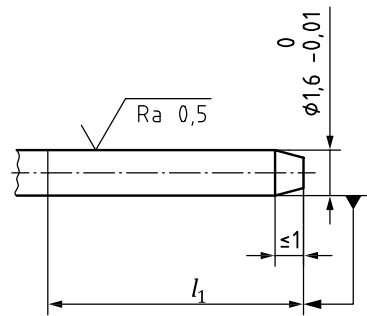

Figure 6 — Dimensions Type 3 shank

Dimensions in millimetres

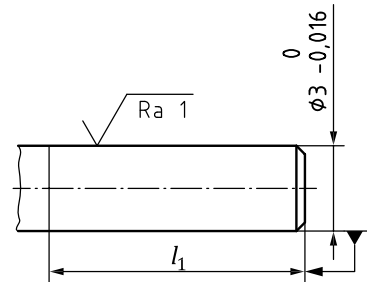

Figure 7 — Dimensions Type 4 shank

Table 1 — Fitting length of shank

Dimensions in millimetres

Shank	Diameter	Fitting length, l_1 min.		
		miniature, short	standard, long	extra long
Type 1 ^a	2,35	—	11	12
Type 2	2,35	15	30	30
Type 3	1,6	9	11	12
Type 4	3	—	30	30

^a The start of any enlargement on a Type 1 shank (e.g. by marking or the working head) shall be outside $l_1 = 13,5$ mm.

5.3 Shank cylindricity

The shank cylindricity, δ (see [Figure 8](#)) shall be within the tolerances of the acceptable shank diameter.

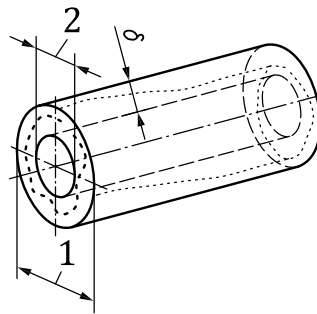

Key

- 1 upper limit of d_1
- 2 lower limit of d_1

Figure 8 — Shank cylindricity

The requirement for the shank cylindricity covers the fitting length, l_1 , of the shank with the exception of the shank end geometry.

Test in accordance with [6.3](#).

5.4 Surface roughness

The surface roughness, Ra , shall be for

- a) Type 1, Type 2, and Type 4: $\leq 1 \mu\text{m}$,
- b) Type 3: $\leq 0,5 \mu\text{m}$,

as it is located and shown in [Figure 4](#) to [Figure 7](#).

Test in accordance with [6.4](#).

5.5 Vickers hardness

The Vickers hardness for shanks made of ceramic material, shall be not less than 1 400 $\text{HV}_{0,5}$.

5.6 Marking

Marking, if envisaged, should be outside the fitting length, l_1 .

If the marking is applied within the fitting length, l_1 , the outside diameter of the shank with the marking shall not exceed the effective diameter of the shank.

Marking shall be resistant to reprocessing procedures such as disinfection, cleaning and sterilization according to the manufacturer's instructions.

6 Test methods

6.1 Shank diameter

Measurements of the shank diameter shall be made in accordance with ISO 8325 with suitable measuring devices with an accuracy of 0,001 mm. The accuracy of the measuring device shall be verified.

The shank diameter, d_1 , shall be measured by traversing the length, l_1 .

6.2 Other dimensions

Measurements shall be made in accordance with ISO 8325 with suitable measuring devices with an accuracy of 0,01 mm. The accuracy of the measuring device shall be verified.

6.3 Shank cylindricity

The test method is left to the discretion of the manufacturer.

6.4 Surface roughness

Test the surface roughness in accordance with ISO 3274 and ISO 4288.

6.5 Vickers hardness

Test the hardness in accordance with ISO 6507-1.

7 Quality control

7.1 Types of shank

For the purpose of quality control, the shanks of the instruments shall be classified as given in [Clause 4](#).

7.2 Defects

7.2.1 Major defects

Major defects shall be those deviations from the specifications listed in [Table 2](#). Major defects include only those items which prevent an instrument from operating.

7.2.2 Minor defects

Minor defects shall be all deviations in fitting dimensions not listed in [Table 2](#). Minor defects include all other deviations from the specification which lower the quality of the instrument.

Acceptable quality levels are given in [Annex A](#).

Table 2 — Major defects

Shank	d_1	d_2	l_3	l_4	s
Type 1	>2,35	>1,45	<1,80	<0,85	>1,80
Type 2	>2,35	—	—	—	—
Type 3	>1,60 <1,59	—	—	—	—
Type 4	>3	—	—	—	—

Annex A (informative)

Acceptable quality levels (AQL)

The acceptable quality level (AQL) expressed in terms of the number of defects per 100 pieces, for each type of instrument, should be as shown in [Table A.1](#).

Table A.1 — Acceptable quality level

Shank	AQL	
	Major defects	Minor defects
Type 1	1	2,5
Type 2	1	2,5
Type 3	1	2,0
Type 4	1	2,5

Bibliography

- [1] ISO 2859-1, *Sampling procedures for inspection by attributes — Part 1: Sampling schemes indexed by acceptance quality limit (AQL) for lot-by-lot inspection*

© ISO 2013 – All rights reserved

11/30/2013 22:27:07 MST

ICS 11.060.20

Price based on 8 pages