**Ships and marine technology — Ships'
side scuttles**

Navires et technologie maritime — Hublots de navires



Reference number
ISO 1751:2012(E)

© ISO 2012



COPYRIGHT PROTECTED DOCUMENT

© ISO 2012

All rights reserved. Unless otherwise specified, no part of this publication may be reproduced or utilized in any form or by any means, electronic or mechanical, including photocopying and microfilm, without permission in writing from either ISO at the address below or ISO's member body in the country of the requester.

ISO copyright office
Case postale 56 • CH-1211 Geneva 20
Tel. + 41 22 749 01 11
Fax + 41 22 749 09 47
E-mail copyright@iso.org
Web www.iso.org

Published in Switzerland

Contents

Page

Foreword	iv
1 Scope	1
2 Normative references	1
3 Terms and definitions	1
4 Classification	2
4.1 Series	2
4.2 Types	2
4.3 Models	2
4.4 Nominal sizes	2
4.5 Survey of types, models and sizes	2
5 Technical requirements	5
5.1 General	5
5.2 Dimensions	5
5.3 Glass retaining frame	7
5.4 Glass panes	9
5.5 Glazing	9
5.6 Fasteners (closing devices and hinges)	9
5.7 Gaskets for glassholder and deadlight	10
6 Materials	10
6.1 General	10
6.2 Main frame, glassholder, glass retaining frame and deadlight	10
6.3 Closing device and hinge pin	12
7 Testing	12
7.1 Board test	12
7.2 Shop test	12
7.3 Mechanical strength test	13
7.4 Fire-resistance test	14
8 Marking	14
8.1 Regular side scuttles (series N)	14
8.2 Side scuttles for fire-resistant constructions (series P)	14
9 Designation	14
9.1 Elements for designation	15
9.2 Examples	15
10 Positioning	15
11 Installation	15
Annex A (normative) Maximum allowable pressure for glass panes for side scuttles	17

© ISO 2012. All rights reserved.
 Provided by IHS under license with ISO.
 No reproduction or networking permitted without license from IHS.

Foreword

ISO (the International Organization for Standardization) is a worldwide federation of national standards bodies (ISO member bodies). The work of preparing International Standards is normally carried out through ISO technical committees. Each member body interested in a subject for which a technical committee has been established has the right to be represented on that committee. International organizations, governmental and non-governmental, in liaison with ISO, also take part in the work. ISO collaborates closely with the International Electrotechnical Commission (IEC) on all matters of electrotechnical standardization.

International Standards are drafted in accordance with the rules given in the ISO/IEC Directives, Part 2.

The main task of technical committees is to prepare International Standards. Draft International Standards adopted by the technical committees are circulated to the member bodies for voting. Publication as an International Standard requires approval by at least 75 % of the member bodies casting a vote.

Attention is drawn to the possibility that some of the elements of this document may be the subject of patent rights. ISO shall not be held responsible for identifying any or all such patent rights.

ISO 1751 was prepared by Technical Committee ISO/TC 8, *Ships and marine technology*, Subcommittee SC 8, *Ship design*.

This third edition cancels and replaces the second edition (ISO 1751:1993), which has been technically revised.

Ships and marine technology — Ships' side scuttles

1 Scope

This International Standard specifies the classification of side scuttles for ships (series, types and models), and gives the dimensions for interchangeability and construction, materials, tests, marking and designation of these framed side scuttles with thermally toughened safety glass panes.

NOTE This International Standard is based on the experience of side scuttles and glass manufacturers, shipbuilders and authorities who apply to ships the Regulations of the *International Convention for the Safety of Life at Sea, 1974 (SOLAS 1974)*, as amended, 1981, and of the *International Convention of Load Lines, 1966*, as amended.

2 Normative references

The following referenced documents are indispensable for the application of this document. For dated references, only the edition cited applies. For undated references, the latest edition of the referenced document (including any amendments) applies.

ISO 261, *ISO general purpose metric screw threads — General plan*

ISO 614, *Ships and marine technology — Toughened safety glass panes for rectangular windows and side scuttles — Punch method of non-destructive strength testing*

ISO 1207, *Slotted cheese head screws — Product grade A*

ISO 1580, *Slotted pan head screws — Product grade A*

ISO 2009, *Slotted countersunk flat head screws — Product grade A*

ISO 2010, *Slotted raised countersunk head screws — Product grade A*

ISO 3902, *Shipbuilding and marine structures — Gaskets for rectangular windows and side scuttles*

ISO 5780, *Shipbuilding — Side scuttles — Positioning*

ISO 5797, *Ships and marine technology — Windows and side scuttles for fire-resistant constructions*

ISO 6345, *Shipbuilding and marine structures — Windows and side scuttles — Vocabulary*

ISO 7045, *Pan head screws with type H or type Z cross recess — Product grade A*

ISO 7046-2, *Countersunk flat head screws (common head style) with type H or type Z cross recess — Product grade A — Part 2: Steel screws of property class 8.8, stainless steel screws and non-ferrous metal screws*

ISO 7047, *Raised countersunk head screws (common head style) with type H or type Z cross recess — Product grade A*

ISO 21005, *Ships and marine technology — Thermally toughened safety glass panes for windows and side scuttles*

3 Terms and definitions

For the purposes of this document, the terms and definitions given in ISO 6345 and ISO 21005 apply.

4 Classification

Side scuttles shall be classified by series, types, models and nominal sizes in accordance with 4.1 to 4.4, respectively.

NOTE A survey of standardized side scuttles is given in 4.5 and Table 3.

Further classification characteristics are the material classes; see 6.2 and Table 10.

4.1 Series

4.1.1 Regular series (N)

Side scuttles of the regular series shall contain a thermally toughened safety glass pane that meets the requirements of ISO 21005.

4.1.2 Fire-resistant series (P)

Side scuttles of the fire-resistant series shall be provided for installation in “A” or “B” class divisions. These side scuttles shall contain glass panes that meet the requirements of ISO 5797.

Modifications to the construction and installation of the glassholder and main frame, as well as additional testing and marking, shall be in accordance with ISO 5797.

4.2 Types

Ships' side scuttles may be of three types:

- Type A: Heavy-type side scuttle;
- Type B: Medium-type side scuttle;
- Type C: Light-type side scuttle.

4.3 Models

Models shall be designated in accordance with the following principal characteristics:

- opening or non-opening model;
- with or without deadlight;
- opening direction of glassholder;
- type of fastening.

The various combinations of these, which are in accordance with the definitions in ISO 6345, are given in Table 1.

4.4 Nominal sizes

The nominal size is defined by the clear light diameter d_1 of the side scuttle; see Table 2.

4.5 Survey of types, models and sizes

A survey is given in Table 3 for all side scuttles standardized in this International Standard. It applies to series N (regular) and series P (fire-resistant) side scuttles.

The illustrations given in Table 3 do not define the construction; they are simplified examples for information only.

Table 1 — Principal characteristics of models

Opening or non-opening	Deadlight	Further attributes	Fastening		Model designation code		
			bolted (B)	welded (W)	Type		
					A	B	C
opening	with	left hand ^a (L)	B	—	LB	—	—
			—	W	LW	—	—
		right hand ^a (R)	B	—	RB	—	—
			—	W	RW	—	—
		common hinged (S)	B	—	SB	—	—
			—	W	SW	—	—
	without	—	B	—	—	—	LRB
		—	—	W	—	—	LRW
non-opening	with	—	B	—	NB	—	—
			—	W	NW	—	—
	without		B	—	—	—	NB
			—	W	—	—	NW

^a The deadlight opening upwards. Opening side scuttles with deadlight opening downwards may be supplied by special agreement only.

Table 2 — Nominal sizes of side scuttles

Type	Nominal size						Illustration
	d_1 mm						
A	200	250	300	350	400	450	
B	200	250	300	350	400	450	
C	200	250	300	350	400	450	

Table 3 — Survey of side scuttles

Type (see 4.2)	Model (see 4.3)		Nominal size d_1 (see 4.4)	Illustration (bolted side scuttles are shown)
	bolted	welded		
Opening side scuttle				
A and B	LB	—	Type A: 200 to 450	<p style="text-align: center;">with deadlight</p> 
	—	LW		
	RB	—		
	—	RW	Type B: 200 to 450	
	SB	—		
	—	SW		
C	LRB	—	200 to 450	<p style="text-align: center;">without deadlight</p> 
	—	LRW		
Non-opening side scuttle				
A and B	NB	—	Type A: 200 to 450	<p style="text-align: center;">with deadlight</p> 
	—	NW	Type B: 200 to 450	
C	NB	—	200 to 450	<p style="text-align: center;">without deadlight</p> 
	—	NW		

5 Technical requirements

5.1 General

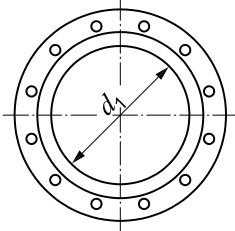
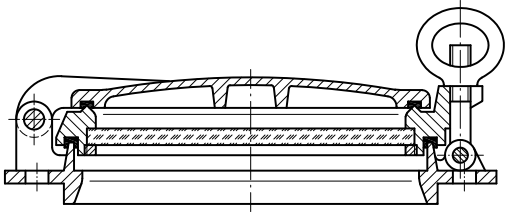
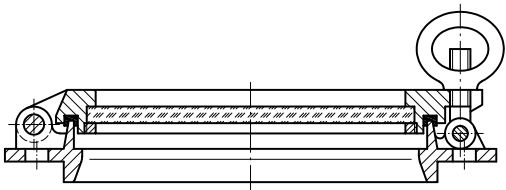
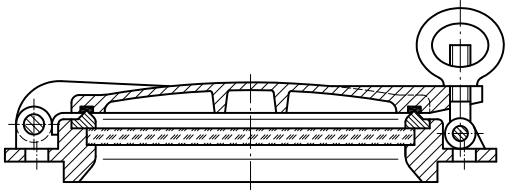
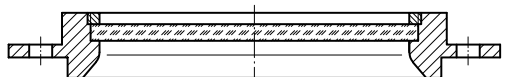
Side scuttles of all series, types, models and nominal sizes shall be manufactured to the requirements (dimensions, materials, etc.) given in this International Standard. They shall be capable of meeting the test requirements specified in Clause 7.

In addition, for side scuttles for fire-resistant construction, the glassholder and the main frame shall be made of a material that keeps its mechanical characteristics at the temperatures given in ISO 5797.

They shall be designed so that temperature gradients do not develop stresses in the glass which could result in rupture.

5.2 Dimensions

5.2.1 Main dimensions

The main dimensions of side scuttles shall be as given in Figure 1 and Tables 4 and 5.

NOTE Figure 1 does not define the construction of any series, type or model of side scuttle; it is given for the indication of standardized dimensions only. The illustration shows an opening side scuttle with deadlight.

Table 4 — Main dimensions and number of fasteners of side scuttles

Nominal size d_1 mm	d_2 mm ± 2	d_3 mm max.	g mm max.	Minimum number of fasteners ^a				
				Type A		Type B		Type C
				glass-holder	dead-light	glass-holder	dead-light	glass-holder
200	250	350	50	2	2	2	2	2
250	305	400	47,5	3	2	3	2	2
300	360	450	45	3	3	3	2	3
350	410	500	45	3	3	3	3	3
400	460	550	45	3	3	3	3	3
450	510	600	45	4	3	4	3	3

^a The number of fasteners comprises only closing devices and hinges with round holes; see 5.6.

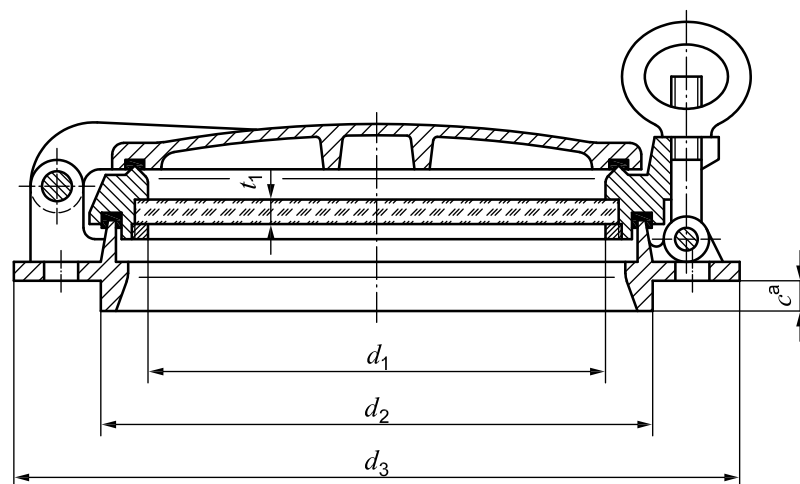

a) Bolted model

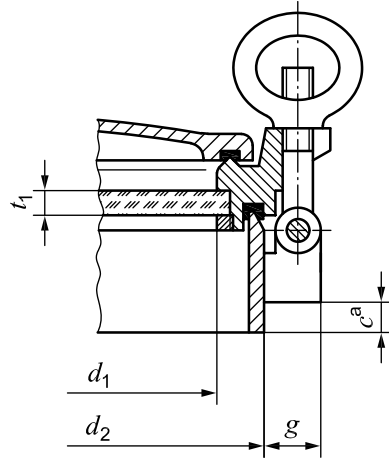

b) Welded model

^a For the spigot height (dimension *c*), see 5.2.2 and Table 5.

Figure 1 — Main dimensions of side scuttle

5.2.2 Height of spigot

The recommended nominal heights of the main frame spigot, which should be preferred for all types, models and nominal sizes of side scuttles, are given in Table 5.

Table 5 — Height of spigot (dimension *c*)

	Model	Manufacturing height mm	Actual height mm
Bolted		16	
Welded		≥ 30	The actual required delivery height of the spigot may be agreed when ordering the side scuttle.

5.2.3 Glass recess

The diameter of the glass recess, *d₄*, in the glassholder of opening side scuttles and in the main frame of non-opening side scuttles shall be as given in Figure 5 and Table 6.

The minimum glass thicknesses for side scuttles series N (regular) are given in ISO 21005.

The minimum glass thicknesses for side scuttles series P (fire-resistant) are given in ISO 5797.

5.3 Glass retaining frame

For fixing the glass pane, a glass retaining frame shall be provided.

Threaded glass retaining frames for screwing in or flanged glass retaining frames with holes for screwing on with screws are acceptable.

5.3.1 Threaded glass retaining frame (RFA)

The main dimensions of a threaded glass retaining frame are given in Figure 2 and Table 6.

A Type RFA glass retaining frame shall not be used for non-opening, welded side scuttles (model NW).

5.3.2 Flanged glass retaining frame (RFB and RFC)

The main dimensions of a flanged glass retaining frame are given in Figures 3 and 4, and Table 6.

A Type RFB glass retaining frame may be used for all types and models of side scuttles.

Type RFC may only be used for side scuttles without deadlight.

5.3.3 Screws for flanged glass retaining frames

To fasten glass retaining frames of Types RFB and RFC, slotted or cross recessed screws in accordance with ISO 1207, ISO 1580, ISO 2009, ISO 2010, ISO 7045, ISO 7046-2 or ISO 7047 shall be used, at the window manufacturer's discretion. Such screws shall have the following characteristics:

- thread: M 6;
- length: minimum 16 mm;
- material: marine corrosion-resistant stainless steel A50, copper alloy and aluminium, strength corresponding to the maximum allowable pressure, see Annex A.

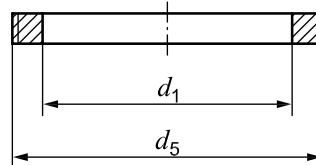
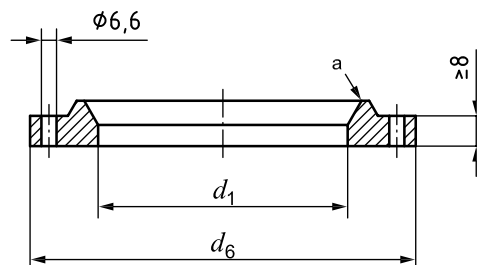

Figure 2 — Glass retaining frame, Type RFA

Dimensions in millimetres



a Sealing surface.

Figure 3 — Flanged glass retaining frame, Type RFB

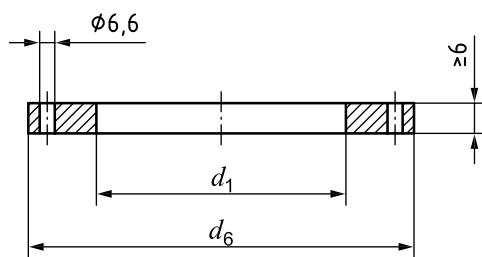
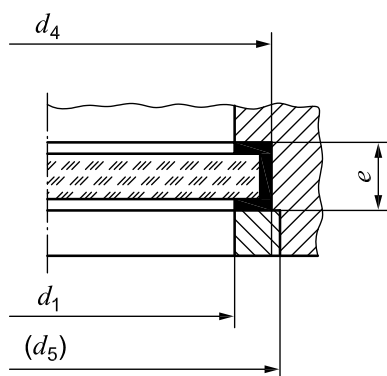
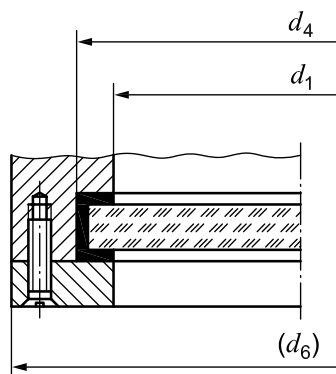

Figure 4 — Flanged glass retaining frame, Type RFC



a) Threaded glass retaining frame



b) Flanged glass retaining frame

Figure 5 — Fixing of glass pane and glass recess

Table 6 — Mounting dimensions for glass pane

Nominal size	200	250	300	350	400	450
d_1 mm	200	250	300	350	400	450
d_4 mm min.	217	267	322	372	422	472
d_5 mm	M 220 × 2	M 270 × 2	M 325 × 2	M 375 × 2	M 425 × 2	M 475 × 2
d_6 mm min.	248	298	348	398	448	498
Number of screw holes ^a	10	12	14	16	18	20
e mm	This dimension is left to the manufacturer's option. It depends on the thickness of the glass pane and glazing sealing material.					
^a Uniform pitch.						

5.4 Glass panes

5.4.1 Panes for regular side scuttles (series N)

Thermally toughened safety glass panes, clear or surface treated, in accordance with ISO 21005 shall be used. Appropriate codes are given in Table 7. Correlation of glass thickness with types and nominal sizes shall be as given in ISO 21005.

Table 7 — Finish of glass pane

Kind of finish	Code
clear	Y1
surface treated	Y2

5.4.2 Panes for side scuttles for fire-resistant constructions (series P)

Glass panes in accordance with ISO 5797 shall be used. Depending on the application conditions, the shipbuilder shall decide for which fire-resistance class the side scuttle is suitable.

5.5 Glazing

5.5.1 Glazing material

An appropriate glazing material, resistant to sea water and ultraviolet light, shall be used.

5.5.2 Mounting of glass pane

When glazing, it is essential that the glass pane is centralized in the glassholder of opening side scuttles or in the main frame of non-opening side scuttles so that there is the same clearance all round.

The necessity of using additional packing for the mounting of special glass panes for side scuttles for fire-resistant constructions (series P) depends on the construction of the mainframe or glassholder, and on the composition and edge protection (if any) of these glass panes.

5.6 Fasteners (closing devices and hinges)

5.6.1 Number of fasteners

- a) The minimum number of fasteners comprising closing devices and hinges with round holes for glassholders and deadlights of Type A, B, and C side scuttles shall be as given in Table 4.

- b) The total number of the fasteners and their construction shall be such that the side scuttle meets the strength and watertightness requirements in Clause 7.

NOTE If the hole for the hinge of the glassholder and/or deadlight is oval, the hinge is not regarded as a fastener.

5.6.2 Closing device

The swing bolt, swing bolt nut and swing bolt hinge pin are component parts of a closing device. Their main dimensions shall be as given in Table 8.

5.6.3 Hinges

The diameter of hinge pins shall be as given in Table 8.

Table 8 — Diameter of bolts and pins

Dimensions in millimetres

Thread of swing bolt and nut (according to ISO 261)	Diameter of hinge pin for	
	swing bolt	glassholder and deadlight
M 20	12	16

5.7 Gaskets for glassholder and deadlight

To ensure watertightness between the glassholder and main frame and also between the deadlight and glassholder, gaskets shall be used.

5.7.1 Type of gasket

The gasket shapes shall be in accordance with ISO 3902, or equivalent, at the manufacturer's direction.

5.7.2 Fixing of gaskets

The gaskets shall be secured in the grooves of the glassholder and deadlight by means of a suitable adhesive.

6 Materials

6.1 General

All materials shall have sufficient mechanical characteristics, and corresponding documentation shall be provided.

6.2 Main frame, glassholder, glass retaining frame and deadlight

The main components of the side scuttle (main frame, glassholder, glass retaining frame and deadlight) shall be manufactured from the materials given in Table 10. These materials shall have the minimum mechanical properties given in Table 11. The values for the minimum tensile strength and minimum elongation given in Table 11 are valid for the types of side scuttle indicated. However, the material used should comply with any relevant national standard.

The material class code numbers given in Table 10, which are for indicating the material in the side scuttle designation, are combinations of the material code numbers, given in Table 9, for the main frame, the glassholder and/or glass retaining frame and the deadlight, in that order.

Table 9 — Material code numbers

Material code no.	Material
1	Copper material (for example brass, gun metal)
2	Ferrous and austenitic material (for example mild steel, stainless steel, cast steel, iron)
3	Aluminium material
0	No components (for example deadlights for Type C side scuttles)

Table 10 — Material classes

Type of side scuttle	Method of fastening side scuttle	Material class code no. in accordance with Table 9	Material		
			main frame	glassholder and/or glass retaining frame	deadlight
A	bolted	112	copper alloy ^a		steel ^b
		212	steel	copper alloy ^a	steel ^b
	welded	222	steel		
B	bolted	112	copper alloy ^a		steel ^b
		333	corrosion-resistant aluminium alloy ^c		
	welded	212	steel	copper alloy ^a	steel ^b
		222	steel		
		333	corrosion-resistant aluminium alloy ^c		
		d	c	c	
C	bolted	110	copper alloy ^a		—
		330	corrosion-resistant aluminium alloy ^c		
	welded	210	steel	copper alloy ^a	
		220	steel		
		330	corrosion-resistant aluminium alloy		
			d	c	

^a The use of brass (cast or wrought) or gun metal is optional.

^b The use of iron (cast iron with spheroidal graphite) or steel or copper alloy or aluminium alloy is optional.

^c The use of cast or wrought alloy is optional.

^d The use of plate or extruded materials is optional.

Table 11 — Tensile strength and elongation for main components

Type of side scuttle	Minimum tensile strength N/mm ²	Minimum elongation %
A	270	10
B	180	10
C	140	8

6.3 Closing device and hinge pin

Swing bolts, pins and nuts of the closing device and hinge pins for the glassholder and deadlight shall be manufactured from materials having the following properties:

- a) resistant to corrosion;
- b) no effect on the corrosion resistance of other parts;
- c) minimum mechanical properties as given in Table 12.

The values for the minimum tensile strength and minimum elongation given in Table 12 are valid for the types of side scuttles indicated. However, the material used should comply with any relevant national standard.

For aluminium alloy side scuttles, the swing bolts and hinge pin of the glassholder shall be made of non-corrodible steel, stainless steel or such alloys as are not likely to cause corrosion of side scuttles, bolts or pins.

Table 12 — Tensile strength and elongation for closing devices

Type of side scuttle	Hinge pin swing bolt and swing bolt pin		Nut	
	minimum tensile strength N/mm ²	minimum elongation %	minimum tensile strength N/mm ²	minimum elongation %
A	350	15	250	14
B	350	15	250	14
C	250	14	180	8

7 Testing

7.1 Board test

To ensure that the side scuttle and packing are watertight when fitted, a hose test or equivalent shall be carried out by the shipbuilder to the satisfaction of the owner’s or surveyor’s representative.

The hose test shall consist of hosing the side scuttle by means of at least 12,5 mm nominal size hose held at a distance of not more than 1,5 m from the side scuttle and with a water pressure of a least 250 kPa.

7.2 Shop test

An equivalent hydraulic test shall be carried out by the manufacturer before despatch by means of batch tests (approximately 10 % of the delivery batch, with a minimum of two side scuttles).

The side scuttle shall be tested by being subjected to the hydraulic pressures given in Table 13, under the following conditions:

Procedure 1: With glass pane and open deadlight except for Type A, with diameters of 350 mm and 400 mm, where at a test pressure of 150 kPa the deadlight shall be closed.

Procedure 2: Without glass pane and with closed deadlight.

The rationale behind procedure 1 is that practice has shown that for normal side scuttles of Type A, with a diameter of 350 mm, 400 mm or 450 mm, when subjected to a test pressure of 150 kPa, the deflection between the fixed points is so heavy that leakage occurs. A closed deadlight would support the glassholder and diminish the deflection.

Table 13 — Test pressures for watertightness

Side scuttle type	Test pressure	
	kPa	
	Procedure 1	Procedure 2
A	150	100
B	75	50
C	35	—

7.3 Mechanical strength test

7.3.1 Prototype test

A prototype side scuttle without glass pane and with closed deadlight shall be subjected to a mechanical strength test by a punch method using the test pressures given in Table 14, see Figure 6.

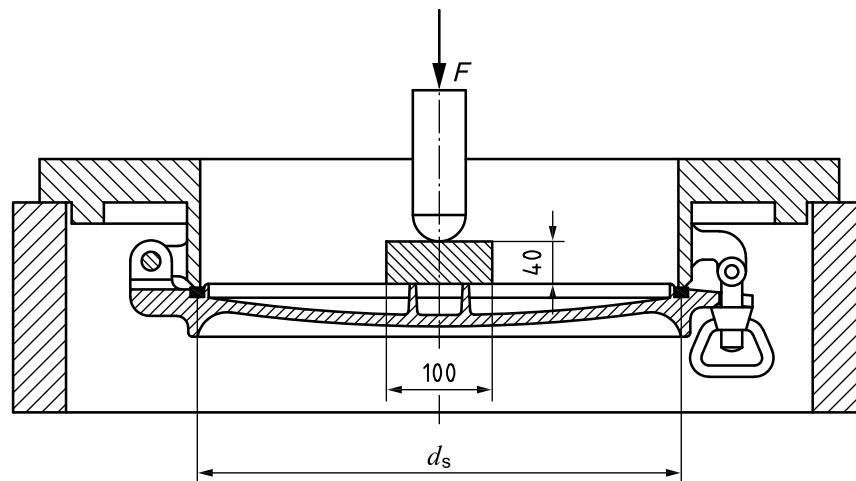

Figure 6 — Prototype test

7.3.2 Test performance

7.3.2.1 The punch shall be placed that side of the deadlight which could be subjected to direct contact with the sea. If the construction of the deadlight makes it necessary, a plate of 100 mm diameter and 10 mm thickness may be placed between the punch and the deadlight.

7.3.2.2 When subjected to the pressure given in Table 14, the permanent deformation of the deadlight shall not exceed 1 % of the nominal size of the side scuttle.

Table 14 — Test pressures for mechanical strength

Side scuttle type	Test pressure
	kPa
A	240
B	120

NOTE The test pressures in Table 14 are the values assumed for the calculation of the proof loads to be applied by the punch test.

7.4 Fire-resistance test

Side scuttles for fire-resistant constructions (series P) shall have been subjected to prototype testing for fire-resistance, see ISO 5797.

8 Marking

Side scuttles conforming to this International Standard shall be marked according to 8.1 to 8.2.2.

8.1 Regular side scuttles (series N)

8.1.1 Marking of body

- a) The main frame or some other metallic main component part shall be marked with the letter for the Type (A, B or C).
- b) Further marking indications are optional, for example:
 - nominal size;
 - material class;
 - manufacturer's name or trade-mark;
 - number of this International Standard¹⁾.

8.1.2 Marking of glass pane

The glass pane shall be marked according to ISO 614.

8.2 Side scuttles for fire-resistant constructions (series P)

8.2.1 Marking of body

The indications given in 8.1.1 apply. In addition, fire-resistant side scuttles shall be marked on the inside of the glassholder with the following indications:

- fire-resistance class (e.g. B-0 or B-15; see 5.4.2);
- number of the test report.

8.2.2 Marking of glass pane

The fire-resistant glass pane shall be marked in accordance with ISO 5797.

9 Designation

For ordering and reference purposes, side scuttles conforming to this International Standard shall be designated in accordance with 9.1 to 9.2.2.

1) Admissible only in connection with the manufacturer's name or trade-mark.

9.1 Elements for designation

The following basic elements and additional elements for the different series of side scuttles (depending on the type of side scuttle glass pane) shall be used, in the order given:

- a) basic elements:
 - 1) denomination (abbreviated): side scuttle;
 - 2) number of this International Standard: ISO 1751;
 - 3) series (code letter), as specified in 4.1;
 - 4) type (code letter), as specified in 4.2;
 - 5) nominal size, as specified in Table 2;
 - 6) height of spigot, as specified in 5.2.2;
 - 7) model (code), as specified in Table 1;
 - 8) material class of side scuttle (code number), as specified in Table 10;
- b) additional elements for designation of regular side scuttles with safety glass panes (series N):
 - finish of glass pane (code), as specified in 5.4.1;
- c) additional elements for designation of side scuttles for fire-resistant constructions (series P):
 - fire-resistance class of side scuttle, as specified in 5.4.2.

9.2 Examples

9.2.1 Example for regular side scuttles (N)

A side scuttle in accordance with this International Standard of regular series (N), heavy type A, nominal size $d_1 = 400$ mm, height of spigot $c = 16$ mm, right-hand opening bolted model (RB), material class 112, with glass pane of plate glass and glass finish clear (Y1) is designated as follows:

Side scuttle ISO 1751-N-A400 × 16-RB-112-Y1

9.2.2 Example for side scuttles for fire-resistant constructions (P)

A side scuttle in accordance with this International Standard of fire-resistance series (P), heavy type A, nominal size $d_1 = 400$ mm, height of spigot $c = 16$ mm, right-hand opening bolted model (RB), material class 112, for fire-resistance class B-15 is designated as follows:

Side scuttle ISO 1751-P-A400 × 16-RB-112-B15

10 Positioning

Side scuttles shall be positioned in accordance with ISO 5780.

11 Installation

For installation the relevant national rules and regulations apply, if any.

The diameter of the pre-cut hole in the shell plate should be as given in Table 15.

Table 15 — Pre-cut hole

Dimensions in millimetres

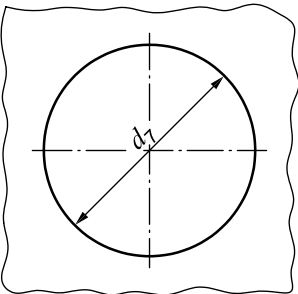
Nominal size d_1	d_7		Illustration
	bolted frame +2 0	welded frame 0 -2	
200	254		
250	309		
300	364		
350	414		
400	464		
450	514		

www.iso.org/iso/home/standards/standards_browse.htm

Annex A (normative)

Maximum allowable pressure for glass panes for side scuttles

The maximum allowable pressure p to which glass panes for side scuttles of regular series N (glazed with toughened safety glass panes in accordance with ISO 21005) and side scuttles of fire-resistance series P (glazed with glass panes in accordance with ISO 5797) may be subjected is given in Table A.1.

Table A.1 — Maximum allowable pressure

Type	Side scuttle Nominal size	Glass thickness ^a	Maximum allowable pressure
	d_1 mm		
A Heavy	200	10	328
	250	12	302
	300	15	328
	350	15	241
	400	19	297
	450	25	406
B Medium	200	8	210
	250	8	134
	300	10	146
	350	12	154
	400	12	118
	450	15	146
C Light	200	8	210
	250	8	134
	300	8	93
	350	8	68
	400	10	82
	450	10	65

^a The glass thickness applies to glass panes of side scuttles (series N) and to the main glass pane of side scuttles for fire-resistant constructions (series P). In special cases, a greater glass thickness shall be used for surface treated glass panes, see ISO 21005.

© ISO 2012. All rights reserved.

ICS 47.020.10

Price based on 17 pages