**Evaporated milk and sweetened
condensed milk — Determination of fat
content — Gravimetric method
(Reference method)**

*Lait concentré sucré et non sucré — Détermination de la teneur en
matière grasse — Méthode gravimétrique (Méthode de référence)*



Reference numbers
ISO 1737:2008(E)
IDF 13:2008(E)

© ISO and IDF 2008

PDF disclaimer

This PDF file may contain embedded typefaces. In accordance with Adobe's licensing policy, this file may be printed or viewed but shall not be edited unless the typefaces which are embedded are licensed to and installed on the computer performing the editing. In downloading this file, parties accept therein the responsibility of not infringing Adobe's licensing policy. Neither the ISO Central Secretariat nor the IDF accepts any liability in this area.

Adobe is a trademark of Adobe Systems Incorporated.

Details of the software products used to create this PDF file can be found in the General Info relative to the file; the PDF-creation parameters were optimized for printing. Every care has been taken to ensure that the file is suitable for use by ISO member bodies and IDF national committees. In the unlikely event that a problem relating to it is found, please inform the ISO Central Secretariat at the address given below.



COPYRIGHT PROTECTED DOCUMENT

© ISO and IDF 2008

All rights reserved. Unless otherwise specified, no part of this publication may be reproduced or utilized in any form or by any means, electronic or mechanical, including photocopying and microfilm, without permission in writing from either ISO or IDF at the respective address below.

ISO copyright office
Case postale 56 • CH-1211 Geneva 20
Tel. + 41 22 749 01 11
Fax + 41 22 749 09 47
E-mail copyright@iso.org
Web www.iso.org

International Dairy Federation
Diamant Building • Boulevard Auguste Reyers 80 • B-1030 Brussels
Tel. + 32 2 733 98 88
Fax + 32 2 733 04 13
E-mail info@fil-idf.org
Web www.fil-idf.org

Published in Switzerland

Contents

Page

Foreword.....	iv
Foreword.....	v
1 Scope	1
2 Normative references	1
3 Term and definitions	1
4 Principle.....	1
5 Reagents.....	2
6 Apparatus	2
7 Sampling.....	3
8 Preparation of test sample.....	4
8.1 Evaporated milk	4
8.2 Sweetened condensed milk.....	4
9 Procedure	4
9.1 Test portion	4
9.2 Blank tests.....	4
9.3 Preparation of fat-collecting vessel	5
9.4 Determination.....	5
10 Calculation and expression of results.....	7
10.1 Calculation.....	7
10.2 Expression of results	8
11 Precision.....	8
11.1 Interlaboratory test	8
11.2 Repeatability.....	8
11.3 Reproducibility.....	8
12 Test report	9
Annex A (informative) Notes on procedures	10
Annex B (informative) Alternative procedure using fat-extraction tubes with siphon or wash-bottle fittings	12
Bibliography	15

Foreword

ISO (the International Organization for Standardization) is a worldwide federation of national standards bodies (ISO member bodies). The work of preparing International Standards is normally carried out through ISO technical committees. Each member body interested in a subject for which a technical committee has been established has the right to be represented on that committee. International organizations, governmental and non-governmental, in liaison with ISO, also take part in the work. ISO collaborates closely with the International Electrotechnical Commission (IEC) on all matters of electrotechnical standardization.

International Standards are drafted in accordance with the rules given in the ISO/IEC Directives, Part 2.

The main task of technical committees is to prepare International Standards. Draft International Standards adopted by the technical committees are circulated to the member bodies for voting. Publication as an International Standard requires approval by at least 75 % of the member bodies casting a vote.

Attention is drawn to the possibility that some of the elements of this document may be the subject of patent rights. ISO shall not be held responsible for identifying any or all such patent rights.

ISO 1737|IDF 13 was prepared by Technical Committee ISO/TC 34, *Food products*, Subcommittee SC 5, *Milk and milk products*, and the International Dairy Federation (IDF). It is being published jointly by ISO and IDF.

This fourth edition of ISO 1737|IDF 13 cancels and replaces the third edition (ISO 1737:1999), of which it constitutes a minor revision.

Foreword

IDF (the International Dairy Federation) is a non-profit organization representing the dairy sector worldwide. IDF membership comprises National Committees in every member country as well as regional dairy associations having signed a formal agreement on cooperation with IDF. All members of IDF have the right to be represented at the IDF Standing Committees carrying out the technical work. IDF collaborates with ISO in the development of standard methods of analysis and sampling for milk and milk products.

Draft International Standards adopted by the Action Teams and Standing Committees are circulated to the National Committees for voting. Publication as an International Standard requires approval by at least 50 % of the IDF National Committees casting a vote.

Attention is drawn to the possibility that some of the elements of this document may be the subject of patent rights. IDF shall not be held responsible for identifying any or all such patent rights.

ISO 1737|IDF 13 was prepared by the International Dairy Federation (IDF) and Technical Committee ISO/TC 34, *Food products*, Subcommittee SC 5, *Milk and milk products*. It is being published jointly by IDF and ISO.

All work was carried out by the Joint ISO-IDF Action Team *Fat* of the Standing Committee on *Main components in milk* under the aegis of its project leader, Mr G.J. Beutick (NL).

This edition of ISO 1737|IDF 13 cancels and replaces IDF 13:1987, of which it constitutes a minor revision.

Evaporated milk and sweetened condensed milk — Determination of fat content — Gravimetric method (Reference method)

WARNING — The use of this International Standard may involve hazardous materials, operations and equipment. This International Standard does not purport to address all the safety problems associated with its use. It is the responsibility of the user of this International Standard to establish safety and health practices and determine the applicability of regulatory limitations prior to use.

1 Scope

This International Standard specifies the reference method for the determination of the fat content of all types of evaporated milk and sweetened condensed milk (liquid sweetened and unsweetened concentrated milk).

2 Normative references

The following referenced documents are indispensable for the application of this document. For dated references, only the edition cited applies. For undated references, the latest edition of the referenced document (including any amendments) applies.

ISO 835, *Laboratory glassware — Graduated pipettes*

ISO 1042, *Laboratory glassware — One-mark volumetric flasks*

ISO 3889|IDF 219, *Milk and milk products — Specification of Mojonnier-type fat extraction flasks*

ISO 4788, *Laboratory glassware — Graduated measuring cylinders*

3 Term and definitions

For the purposes of this document, the following terms and definitions apply.

3.1

fat content of evaporated milk and sweetened condensed milk

mass fraction of substances determined by the procedure specified in this International Standard

NOTE The fat content is expressed as a percentage mass fraction.

4 Principle

An ammoniacal ethanolic solution of a test portion is extracted with diethyl ether and light petroleum. The solvents are removed by distillation or evaporation. The mass of the substances extracted is determined.

NOTE This is usually known as the Röse-Gottlieb principle.

5 Reagents

Use only reagents of recognized analytical grade, unless otherwise specified, and distilled or demineralized water or water of equivalent purity.

The reagents shall leave no appreciable residue when the determination is carried out by the method specified (see 9.2.2).

5.1 Ammonia solution, containing a mass fraction of NH_3 of approximately 25 % ($\rho_{20} = 910 \text{ g/l}$).

NOTE If ammonia solution of this concentration is not available, a more concentrated solution of known concentration may be used (see 9.4.2).

5.2 Ethanol ($\text{C}_2\text{H}_5\text{OH}$), or ethanol denatured by methanol, containing a volume fraction of ethanol of at least 94 %. (See Clause A.5.)

5.3 Congo red solution

Dissolve 1 g of Congo red ($\text{C}_{32}\text{H}_{22}\text{N}_6\text{Na}_2\text{O}_6\text{S}_2$) in water in a 100 ml one-mark volumetric flask (6.14). Make up to the mark with water.

NOTE The use of this solution, which allows the interface between the solvent and aqueous layers to be seen more clearly, is optional (see 9.4.3). Other aqueous indicator solutions can be used provided that they do not affect the result of the determination.

5.4 Diethyl ether ($\text{C}_2\text{H}_5\text{OC}_2\text{H}_5$), free from peroxides (see Clause A.3), containing no more than 2 mg/kg of antioxidants, and complying with the requirements for the blank test (see 9.2.2, Clauses A.1 and A.4).

WARNING — The use of diethyl ether can lead to hazardous situations. Observe current safety precautions for handling, use, and disposal.

5.5 Light petroleum, with any boiling range between 30 °C and 60 °C or, as equivalent, **pentane** ($\text{CH}_3[\text{CH}_2]_3\text{CH}_3$) with a boiling point of 36 °C and complying with the requirements for the blank test (see 9.2.2, Clauses A.1 and A.4).

The use of pentane is recommended because of its higher purity and consistent quality.

5.6 Mixed solvent

Shortly before use, mix equal volumes of diethyl ether (5.4) and light petroleum (5.5).

6 Apparatus

WARNING — Since the determination involves the use of volatile flammable solvents, all electrical apparatus employed shall comply with legislation relating to the hazards in using such solvents.

Usual laboratory equipment and, in particular, the following.

6.1 Analytical balance, capable of weighing to the nearest 1 mg, with a readability of 0,1 mg.

6.2 Centrifuge, capable of holding the fat-extraction flasks or tubes (6.6) and capable of spinning at a rotational frequency of 500 min^{-1} to 600 min^{-1} to produce a radial acceleration of 80g to 90g at the outer end of the flasks or tubes.

The use of the centrifuge is optional but recommended (see 9.4.6).

6.3 Distillation or evaporation apparatus, for distilling the solvents and ethanol from the boiling or conical flasks, or evaporating from beakers and dishes (see 9.4.13) at a temperature not exceeding 100 °C.

6.4 Drying oven, electrically heated, with ventilation port(s) fully open, capable of being maintained at a temperature of $102\text{ °C} \pm 2\text{ °C}$ throughout its working space.

The oven shall be fitted with a suitable thermometer.

6.5 Water baths, capable of being maintained at a temperature of between 30 °C and 40 °C , and 40 °C and 60 °C .

6.6 Mojonnier-type fat-extraction flasks, as specified in ISO 3889|IDF 219.

NOTE It is also possible to use fat-extraction tubes with siphon or wash-bottle fittings, but then the procedure is different. The alternative procedure is given in Annex B.

The fat-extraction flasks shall be provided with good quality cork bungs or stoppers of other material (e.g. silicone rubber or polytetrafluoroethylene) unaffected by the reagents used. Cork bungs shall be extracted with the diethyl ether (5.4), kept in water at a temperature of 60 °C or more for at least 15 min, and shall then be allowed to cool in the water so that they are saturated when used.

6.7 Rack, for holding the fat-extraction flasks (or tubes) (6.6).

6.8 Wash bottle, suitable for use with the mixed solvent (5.6).

A plastics wash bottle shall not be used.

6.9 Fat-collecting vessels, such as boiling flasks (flat-bottomed), of capacities 125 ml to 250 ml, conical flasks, of capacity 250 ml, or metal dishes.

If metal dishes are used, they shall be of stainless steel, flat-bottomed with a diameter of 80 mm to 100 mm and a height of approximately 50 mm.

6.10 Boiling aids, fat-free, of non-porous porcelain or silicon carbide (optional when metal dishes are used).

6.11 Measuring cylinders, of capacities 5 ml and 25 ml, complying with the requirements of ISO 4788, class A, or any other apparatus suitable for the product concerned.

6.12 Pipettes, graduated, of capacity 10 ml, complying with the requirements of ISO 835, class A.

6.13 Tongs, made of metal, for holding flasks, beakers or dishes.

6.14 Volumetric flask, one-mark, of capacity 100 ml, complying with the requirements of ISO 1042, class A.

7 Sampling

A representative sample should have been sent to the laboratory. It should not have been damaged or changed during transport or storage.

Sampling is not part of the method specified in this International Standard. A recommended sampling method is given in ISO 707|IDF 50^[1].

Store laboratory samples at a temperature between 2 °C and 6 °C from the time of sampling to the time of commencing the procedure. Store samples in sealed cans unopened at a temperature below 20 °C .

8 Preparation of test sample

8.1 Evaporated milk

Shake and invert the sample container. Open the sample container and pour the sample slowly into a second sample container (provided with an airtight lid). Mix by repeated transfer, taking care to incorporate in the sample any fat or other constituent adhering to the wall and ends of the first container. Finally, transfer the product as completely as possible to the second container.

If necessary in the case of samples in sealed cans, condition the unopened container in the water bath (6.5) maintained at a temperature of between 40 °C and 60 °C. Remove and shake the can vigorously every 15 min. After 2 h, remove the can and allow it to cool to room temperature.

Remove the lid entirely and thoroughly mix the sample by stirring with a spoon or spatula. (If fat separates, do not test the sample.)

8.2 Sweetened condensed milk

Open the sample container and mix thoroughly with a spoon or spatula. Use an up-and-down rotary movement in such a way that the top layers and the content of the lower corners of the container are moved and mixed. Take care to incorporate in the sample any milk adhering to the wall and ends of the container. Transfer the sample as completely as possible to a second sample container (provided with an airtight lid). Close the second container.

If necessary, in the case of samples in sealed cans, condition the unopened can in the water bath (6.5) at a temperature of between 30 °C and 40 °C. Open the can, scrape out all milk adhering to the interior of the can, transfer to a dish large enough to permit stirring thoroughly and mix until the whole mass is homogeneous.

In the case of a sample in a collapsible tube, open the tube and transfer the contents to a jar. Then cut open the tube and scrape out all material adhering to the interior and add to the contents of the jar.

9 Procedure

NOTE An alternative procedure using fat-extraction tubes with siphon or wash-bottle fittings (see Note to 6.6) is given in Annex B.

9.1 Test portion

Mix the test sample (Clause 8), by stirring in the case of sweetened condensed milk, or by gently inverting the bottle three or four times in the case of evaporated milk. Immediately weigh, to the nearest 1 mg, directly or by difference, 4,000 g to 5,000 g of the test sample of evaporated milk, or 2,000 g to 2,500 g of the test sample of sweetened condensed milk in a fat-extraction flask (6.6).

Transfer the test portion as completely as possible into the lower (small) bulb of the fat-extraction flask.

9.2 Blank tests

9.2.1 Blank test for method

Carry out a blank test simultaneously with the determination using the same procedure and same reagents, but replacing the test portion by 10 ml of water (see Clause A.2).

When one blank sample is used for a batch of test samples of which the individual samples may not have exactly the same conditions, ensure that the procedure for obtaining the value of the blank used in the calculation of the result corresponds exactly to that of the individual test sample.

If the value obtained in the blank test regularly exceeds 1,0 mg, check the reagents if this has not been recently done (9.2.2). Corrections of more than 2,5 mg should be mentioned in the test report.

9.2.2 Blank test for reagents

To test the quality of the reagents, carry out a blank test as specified in 9.2.1. Additionally, use an empty fat-collecting vessel, prepared as specified in 9.3, for mass control purposes. The reagents shall leave no residue greater than 1,0 mg (see Clause A.1).

If the residue of the complete reagent blank test is greater than 1,0 mg, determine the residue of the solvents separately by distilling 100 ml of the diethyl ether (5.4) and light petroleum (5.5), respectively. Use an empty fat-collecting vessel, prepared for control purposes as in the preceding paragraph, to obtain the real mass of residue which shall not exceed 1,0 mg.

Very occasionally, the solvents may contain volatile matter which is strongly retained in fat. If there are indications of the presence of such substances, carry out blank tests on all the reagents and for each solvent using a fat-collecting vessel with about 1 g of anhydrous butterfat. If necessary, redistil solvents in the presence of 1 g of anhydrous butterfat per 100 ml of solvent. Use the solvents only shortly after the redistillation.

Replace unsatisfactory reagents and solvents, or redistil solvents.

9.3 Preparation of fat-collecting vessel

Dry a fat-collecting vessel (6.9) with a few boiling aids (6.10) in the oven (6.4) maintained at 102 °C for 1 h.

NOTE 1 Boiling aids are desirable to promote gentle boiling during the subsequent removal of solvents, especially when using glass fat-collecting vessels; their use is optional with metal dishes.

Protect the fat-collecting vessel from dust and allow it to cool to the temperature of the weighing room (glass fat-collecting vessel for at least 1 h; metal dish for at least 30 min).

To avoid insufficient cooling or unduly long cooling times, the fat-collecting vessel should not be placed in a desiccator.

Use tongs (6.13) to place the fat-collecting vessel on the balance. Weigh the fat-collecting vessel to the nearest 1,0 mg.

NOTE 2 The use of tongs effectively avoids, in particular, inducing temperature variations.

9.4 Determination

9.4.1 Carry out the determination without delay.

Add water at a temperature of about 50 °C to the test portion in the fat-extraction flask (9.1) to obtain a total volume of 10 ml to 11 ml. Use the water to wash the test portion on to the bottom of the flask. Shake gently with slight warming at about 50 °C in the water bath (6.5) until the test portion is completely dispersed. Cool in running water to room temperature.

9.4.2 Add 2 ml of ammonia solution (5.1) to the dispersed test portion in the fat-extraction flask (9.4.1), or an equivalent volume of a more concentrated ammonia solution (see Note to 5.1). Mix thoroughly with the test portion in the small bulb of the fat-extraction flask.

9.4.3 Add 10 ml of ethanol (5.2). Mix gently but thoroughly by allowing the contents of the fat-extraction flask to flow backwards and forwards between the small and large bulb. Avoid bringing the liquid too near to the neck of the flask. If desired, add 2 drops of the Congo red solution (5.3).

9.4.4 Add 25 ml of diethyl ether (5.4). Close the fat-extraction flask with a cork bung saturated with water or with a stopper of other material wetted with water (6.6). Shake the flask vigorously, but not excessively, for 1 min to avoid the formation of persistent emulsions.

While shaking, keep the fat-extraction flask in a horizontal position with the small bulb extending upwards, periodically allowing the liquid to run from the large bulb into the small bulb. If necessary, cool the flask in running water to about room temperature. Carefully remove the bung or stopper and rinse it and the neck of the flask with a little mixed solvent (5.6). Use the wash bottle (6.8) so that the rinsings run into the flask.

9.4.5 Add 25 ml of the light petroleum (5.5). Close the fat-extraction flask with the rewetted (by dipping into water) bung or stopper. Shake the flask gently again for 30 s as specified in 9.4.3. Proceed with shaking as specified in 9.4.4.

9.4.6 Centrifuge the closed fat-extraction flask for between 1 min and 5 min at a radial acceleration of 80g to 90g. If a centrifuge (6.2) is not available, allow the closed flask to stand in the rack (6.7) for at least 30 min until the supernatant layer is clear and distinctly separated from the aqueous layer. If necessary, cool the flask in running water, to room temperature.

9.4.7 Carefully remove the bung or stopper and rinse it and the inside of the neck of the fat-extraction flask with a little mixed solvent (5.6). Use the wash bottle (6.8) so that the rinsings run into the flask. If the interface is below the bottom of the stem of the flask, raise it slightly above this level by gently adding water down the side of the flask (see Figure 1) to facilitate the decanting of solvent.

NOTE In Figures 1 and 2, one of the three types of fat-extraction flasks as specified in ISO 3889|IDF 219 has been chosen, but this does not imply any preference over other types.

9.4.8 Hold the fat-extraction flask by the small bulb and carefully decant as much as possible of the supernatant layer into the prepared fat-collecting vessel (see 9.3) containing a few boiling aids (6.10) in the case of a boiling or conical flask (optional with metal dishes). Avoid decanting any of the aqueous layer (see Figure 2).

9.4.9 Rinse the outside of the neck of the fat-extraction flask with a little mixed solvent (5.6). Collect the rinsings in the fat-collecting vessel. Take care that the mixed solvent does not spread over the outside of the fat-extraction flask. If desired, remove the solvent or a part of it from the fat-collecting vessel by distillation or evaporation as specified in 9.4.13.

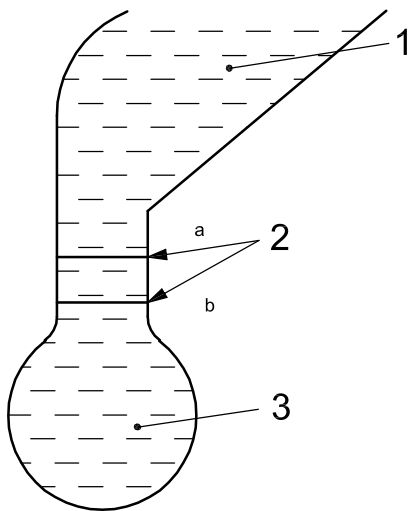

Key

- 1 solvent
- 2 interface
- 3 aqueous layer
- a At second and third extraction.
- b At first extraction.

Figure 1 — Before decanting

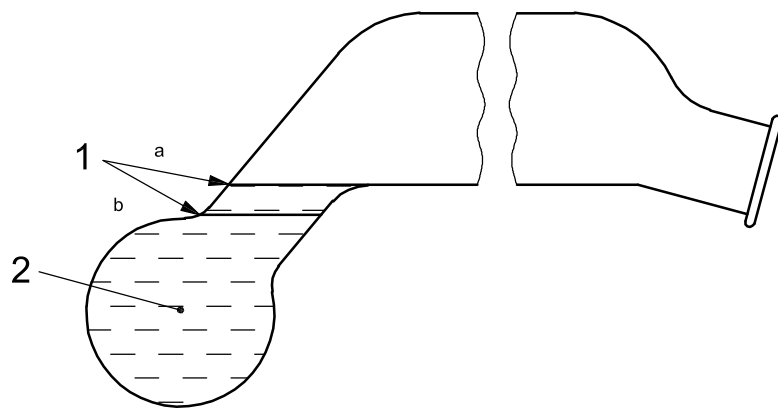

Key

- 1 interface
- 2 aqueous layer
- a At second and third extraction.
- b At first extraction.

Figure 2 — After decanting

9.4.10 Add 5 ml of ethanol (5.2) to the contents of the fat-extraction flask. Using the ethanol, rinse the inside of the neck of the flask and mix as specified in 9.4.3.

9.4.11 Carry out a second extraction by repeating the operations specified in 9.4.4 to 9.4.8 inclusive. Instead of 25 ml, use only 15 ml of diethyl ether (5.4) and 15 ml of light petroleum (5.5). Using the diethyl ether, also rinse the inner wall of the neck of the fat-extraction flask.

If necessary, raise the interface slightly to the middle of the stem of the flask by gently adding water down the side of the flask (see Figure 1) to enable the final decanting of solvent to be as complete as possible (see Figure 2).

9.4.12 Carry out a third extraction without addition of ethanol by again repeating the operations specified in 9.4.4 to 9.4.8 inclusive. Again, use only 15 ml of diethyl ether (5.4) and 15 ml of light petroleum (5.5). Using the diethyl ether, rinse the inside of the neck of the fat-extraction flask again.

If necessary, raise the interface slightly to the middle of the stem of the flask by gently adding water down the side of the flask (see Figure 1) to enable the final decanting of solvent to be as complete as possible (see Figure 2).

NOTE The third extraction may be omitted for evaporated milk and sweetened condensed milk with a fat content of less than 1 % mass fraction.

9.4.13 Remove the solvents (including the ethanol) as completely as possible from the fat-collecting vessel, by distillation if using a boiling or conical flask, or by evaporation if using a beaker or dish (6.3). Rinse the inside of the neck of the boiling or conical flask with a little mixed solvent (5.6) before commencing the distillation.

9.4.14 Heat the fat-collecting vessel, with the boiling or conical flask placed on its side to allow solvent vapour to escape, for 1 h in the drying oven (6.4) maintained at 102 °C. Remove the fat-collecting vessel from the oven and immediately verify whether or not the fat is clear. If the fat is not clear, fatty extraneous matter is presumed to be present and the whole procedure shall be repeated. If the fat is clear, protect the fat-collecting vessel from dust and allow the fat-collecting vessel to cool (preferably not in a desiccator) to the temperature of the weighing room (a glass fat-collecting vessel for at least 1 h, a metal dish for at least 30 min).

Do not wipe the fat-collecting vessel immediately before weighing. Use tongs (6.13) to place the fat-collecting vessel on the balance. Weigh the fat-collecting vessel to the nearest 1,0 mg.

9.4.15 Heat the fat-collecting vessel, with the boiling or conical flask placed on its side to allow solvent vapour to escape, for a further 30 min in the drying oven (6.4) maintained at 102 °C. Cool and reweigh as specified in 9.4.14. If necessary, repeat the heating and weighing procedures until the mass of the fat-collecting vessel decreases by 1,0 mg or less, or increases between two successive weighings. Record the minimum mass as the mass of the fat-collecting vessel and extracted matter.

10 Calculation and expression of results

10.1 Calculation

Calculate the fat content, w_f , expressed as a percentage mass fraction, of the sample using Equation (1):

$$w_f = \frac{(m_1 - m_2) - (m_3 - m_4)}{m_0} \times 100 \quad (1)$$

where

m_0 is the mass, in grams, of the test portion (9.1);

m_1 is the mass, in grams, of the fat-collecting vessel and extracted matter, determined in 9.4.15;

m_2 is the mass, in grams, of the prepared fat-collecting vessel (9.3);

m_3 is the mass, in grams, of the fat-collecting vessel used in the blank test (9.2) and any extracted matter determined in 9.4.15;

m_4 is the mass, in grams, of the fat-collecting vessel (9.3) used in the blank test (9.2).

10.2 Expression of results

Round the result to two decimal places.

11 Precision

11.1 Interlaboratory test

Details of an interlaboratory test in accordance with ISO 5725:1986¹⁾ (see Reference [2]) on the precision of the method appear in Reference [3].

The values for repeatability and reproducibility limits are expressed for the 95 % probability level and may not be applicable to concentration ranges and matrices other than those given.

11.2 Repeatability

The absolute difference between two independent single test results, obtained using the same method on identical test material in the same laboratory by the same operator using the same equipment within a short interval of time, will in not more than 5 % of cases be greater than a mass fraction of fat of:

- a) 0,02 % for products with a fat content < 1 %;
- b) 0,03 % for products with a fat content from 1 % to 4 %;
- c) 0,04 % for products with a fat content from 4 % to 10 %;
- d) 0,50 % of the proportion of fat in the test sample for products with a fat content > 10 %.

11.3 Reproducibility

The absolute difference between two independent single test results, obtained using the same method on identical test material in different laboratories with different operators using different equipment, will in not more than 5 % of cases be greater than a mass fraction of fat of:

- a) 0,03 % for products with a fat content < 1 %;
- b) 0,04 % for products with a fat content from 1 % to 4 %;
- c) 0,06 % for products with a fat content from 4 % to 10 %;
- d) 1 % of the proportion of fat in the test sample for products with a fat content > 10 %.

1) ISO 5725:1986 (now superseded) was used to obtain the precision data.

12 Test report

The test report shall include at least the following information:

- a) all information necessary for the complete identification of the sample;
- b) the sampling method used, if known;
- c) the test method used, together with reference to this International Standard;
- d) all operating details not specified in this International Standard, or regarded as optional, together with details of any incidents which may have influenced the test result(s);
- e) the corrections made, if a value of more than 2,5 mg is obtained in the blank test for the method;
- f) the test result(s) obtained or, if the repeatability has been checked, the final quoted result obtained.

Annex A (informative)

Notes on procedures

A.1 Blank test to check the reagents (see 9.2.2)

In this blank test, a fat-collecting vessel for mass control purposes has to be used so that changes in the atmospheric condition of the balance room or temperature effects of the fat-collecting vessel do not falsely suggest the presence or absence of non-volatile matter in the extract of the reagents. This fat-collecting vessel may be used as a counterweight vessel in the case of a two-pan balance. Otherwise, deviations of the apparent mass ($m_3 - m_4$ in 10.1) of the fat-collecting vessel for control purposes should be considered when checking the mass of the fat-collecting vessel used for the blank test. Hence, the change in apparent mass of the fat-collecting vessel, corrected for the apparent change in mass of the fat-collecting vessel for control purposes, shall show no increase in mass greater than 1,0 mg.

Very occasionally, the solvents may contain volatile matter which is strongly retained in fat. If there are indications of the presence of such substances, carry out blank tests on all the reagents and for each solvent using a fat-collecting vessel with about 1 g of anhydrous butterfat. If necessary, redistil solvents in the presence of 1 g of anhydrous butterfat per 100 ml of solvent. Use the solvents only shortly after redistillation.

A.2 Blank test carried out simultaneously with the determination (see 9.2.1)

The value obtained in the blank test, carried out simultaneously with the determination, enables the apparent mass of substances extracted from a test portion ($m_1 - m_2$) to be corrected for the presence of any non-volatile matter derived from the reagents and also for any change of atmospheric conditions of the balance room and some temperature difference between the fat-collecting vessel and the balance room at the two weighings (9.4.15 and 9.3).

Under favourable conditions (low value in the blank test on reagents, equable temperature of the balance room, sufficient cooling time for fat-collecting vessel), the value will usually be less than 1,0 mg and can then be neglected in the calculation in the case of routine determinations. Slightly higher values (positive and negative) up to 2,5 mg are also often encountered. After correction for these values, the results will still be accurate. Corrections of more than 2,5 mg should be mentioned in the test report (Clause 12).

If the value obtained in this blank test regularly exceeds 1,0 mg, the reagents should be checked, if no recent check has been made. Any impure reagent or reagents traced should be replaced or purified (see 9.2.2 and Clause A.1).

A.3 Test for peroxides

To test for peroxides, add 1 ml of a freshly prepared 100 g/l potassium iodide solution to 10 ml of diethyl ether (5.4) in a small glass-stoppered cylinder which has been previously rinsed with the ether. Shake the cylinder and allow to stand for 1 min. No yellow colour should be observed in the diethyl ether layer.

Other suitable methods of testing for peroxides may be used.

To ensure that the diethyl ether is free, and is maintained free, from peroxides, treat the diethyl ether, at least 3 days before it is to be used, as follows.

Cut zinc foil into strips that will reach at least halfway up the bottle containing the diethyl ether, using approximately 8 000 mm² of foil per litre of diethyl ether.

Before use, completely immerse the strips of foil for 1 min in a solution containing 10 g of copper(II) sulfate pentahydrate (CuSO₄·5H₂O) and 2 ml of concentrated (98 % mass fraction) sulfuric acid per litre. Wash the strips gently but thoroughly with water, place the wet copper-plated strips in the bottle containing the diethyl ether, and leave the strips in the bottle.

Other methods may be used provided that they do not affect the result of the determination.

A.4 Diethyl ether containing antioxidants

Diethyl ether containing about 1 mg of antioxidants per kilogram is available in some countries, especially for fat determinations. This content does not exclude its use for reference purposes.

In other countries, diethyl ether with higher antioxidant contents, for example up to 7 mg/kg, is available. Such ether should only be used for routine determinations with an obligatory blank test carried out simultaneously with the determination(s) to correct for systematic errors due to the antioxidant residue. For reference purposes, such diethyl ether shall always be distilled before use.

A.5 Ethanol

Ethanol denatured otherwise than by the addition of methanol may be used, provided that the denaturant does not affect the result of the determination.

Annex B (informative)

Alternative procedure using fat-extraction tubes with siphon or wash-bottle fittings

B.1 General

If fat-extraction tubes with siphon or wash-bottle fittings are to be used, use the procedure specified in this annex. The tubes shall be provided with good quality cork bungs or stoppers as specified for the flasks in 6.6 (see Figure B.1 as an example).

B.2 Procedure

B.2.1 Preparation of test sample

See Clause 8.

B.2.2 Test portion

Proceed as specified in 9.1, but using the fat-extraction tubes (see Note in 6.6 and Figure B.1).

The test portion shall be delivered as completely as possible to the bottom of the fat-extraction tube.

B.2.3 Blank test

See 9.2 and Clause A.2.

B.2.4 Preparation of fat-collecting vessel

See 9.3.

B.2.5 Determination

B.2.5.1 Carry out the determination without delay.

Add water at about 50 °C to the test portion in the fat-extraction tube (B.2.2) to obtain a total volume of 10 ml to 11 ml. Use the water to wash the test portion on to the bottom of the tube. Shake gently with slight warming at about 50 °C in the water bath (6.5) until the test portion is completely dispersed. Cool in running water to room temperature.

B.2.5.2 Add 2 ml of ammonia solution (5.1) to the dispersed test portion in the fat-extraction tube (B.2.5.1), or an equivalent volume of a more concentrated ammonia solution (see Note to 5.1). Mix thoroughly with the pretreated test portion at the bottom of the fat-extraction tube.

B.2.5.3 Add 10 ml of ethanol (5.2). Mix gently but thoroughly at the bottom of the fat-extraction tube. If desired, add 2 drops of the Congo red solution (5.3).

B.2.5.4 Add 25 ml of diethyl ether (5.4). Close the fat-extraction tube with a cork bung saturated with water or with a stopper of other material wetted with water (6.6). Shake the tube vigorously, but not excessively, with repeated inversions, for 1 min, to avoid the formation of persistent emulsions. If necessary, cool the tube in running water. Carefully remove the bung or stopper and rinse it and the neck of the tube with a little mixed solvent (5.6). Use the wash bottle (6.8) so that the rinsings run into the tube.

Dimensions in millimetres

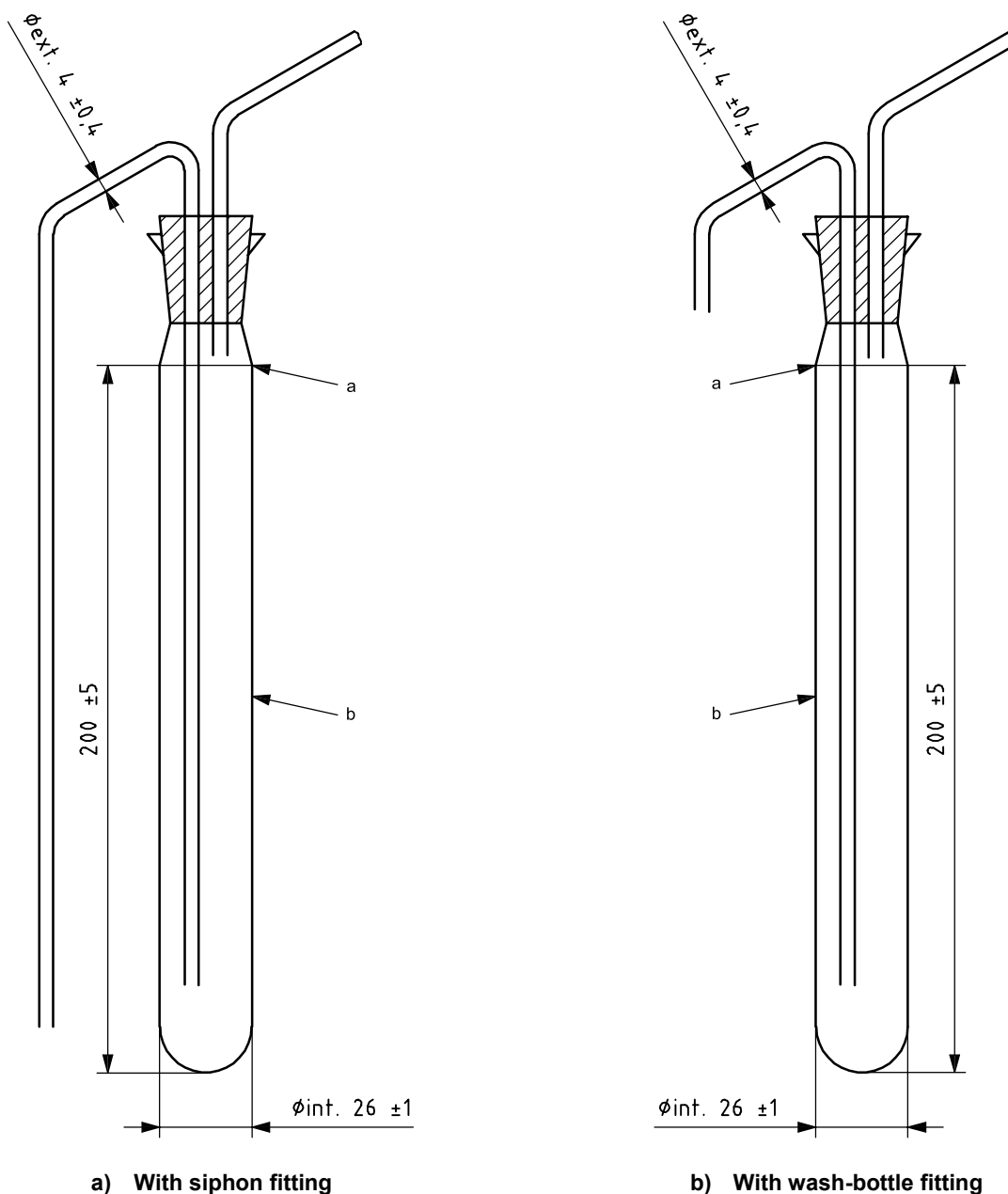

- a Capacity to this level with fittings removed $105 \text{ ml} \pm 5 \text{ ml}$.
- b Wall thickness $1,5 \text{ mm} \pm 0,5 \text{ mm}$.

Figure B.1 — Examples of fat-extraction tubes

B.2.5.5 Add 25 ml of the light petroleum (5.5). Close the fat-extraction tube with the rewetted (by dipping in water) bung or stopper. Shake the tube gently for 30 s, as described in B.2.5.4.

B.2.5.6 Centrifuge the closed fat-extraction tube for 1 min to 5 min at a radial acceleration of $80g$ to $90g$. If a centrifuge (6.2) is not available, allow the closed tube to stand in the rack (6.7) for at least 30 min until the supernatant layer is clear and distinctly separated from the aqueous layer. If necessary, cool the tube in running water to room temperature.

B.2.5.7 Carefully remove the bung or stopper and rinse it and the neck of the fat-extraction tube with a little mixed solvent (5.6). Use the wash bottle (6.8) so that the rinsings run into the tube.

B.2.5.8 Insert a siphon fitting or a wash-bottle fitting into the fat-extraction tube. Push down the long inner limb of the fitting until the inlet is approximately 4 mm above the interface between the layers. The inner limb of the fitting shall be parallel to the axis of the fat-extraction tube.

Carefully transfer the supernatant layer out of the fat-extraction tube into the fat-collecting vessel (see 9.3) containing a few boiling aids (6.10) in the case of boiling or conical flasks (optional with metal dishes). Avoid the transfer of any of the aqueous layer. Rinse the outlet of the fitting with a little mixed solvent, collecting the rinsings in the fat-collecting vessel.

NOTE The supernatant layer can be transferred out of the fat-extraction tube by using, for example, a rubber bulb attached to the short stem to apply pressure.

B.2.5.9 Loosen the fitting from the neck of the fat-extraction tube. Slightly raise the fitting and rinse the lower part of its long inner limb with a little mixed solvent (5.6). Lower and re-insert the fitting and transfer the rinsings to the fat-collecting vessel.

Rinse the outlet of the fitting with a little mixed solvent again, collecting the rinsings in the fat-collecting vessel. If desired, remove the solvent or a part of it from the fat-collecting vessel by distillation or evaporation as specified in 9.4.13.

B.2.5.10 Again loosen the fitting from the neck. Slightly raise the fitting and add 5 ml of ethanol to the contents of the fat-extraction tube. Use the ethanol to rinse the long inner limb of the fitting. Mix as described in B.2.5.3.

B.2.5.11 Carry out a second extraction by repeating the operations described in B.2.5.4 to B.2.5.10. Instead of 25 ml, use only 15 ml of diethyl ether (5.4) and 15 ml of light petroleum (5.5). Using the diethyl ether, rinse the long inner limb of the fitting during the removal of the fitting from the fat-extraction tube after the previous extraction.

B.2.5.12 Carry out a third extraction without the addition of ethanol by again repeating the operations described in B.2.5.4 to B.2.5.10. Again, use only 15 ml of diethyl ether and 15 ml of light petroleum. Using the diethyl ether, rinse the long inner limb of the fitting as described in B.2.5.11.

NOTE The third extraction can be omitted for evaporated milk and sweetened condensed milk with a fat content of less than 1 % mass fraction.

B.2.5.13 Proceed as specified in 9.4.13 to 9.4.15.

Bibliography

- [1] ISO 707|IDF 50, *Milk and milk products — Guidance on sampling*
- [2] ISO 5725:1986²⁾, *Precision of test methods — Determination of repeatability and reproducibility for a standard test method by inter-laboratory tests*
- [3] INTERNATIONAL DAIRY FEDERATION. Interlaboratory collaborative studies, Second series. *Bull. Int. Dairy Fed.* 1988, (235)

2) Superseded.

ISO 1737:2008(E)
IDF 13:2008(E)

ICS 67.100.10

Price based on 15 pages