

INTERNATIONAL STANDARD

**ISO
1726**

Third edition
2000-05-15

Road vehicles — Mechanical coupling between tractors and semi-trailers — Interchangeability

Véhicules routiers — Liaisons mécaniques entre tracteurs et semi-remorques — Interchangeabilité



Reference number
ISO 1726:2000(E)

© ISO 2000

PDF disclaimer

This PDF file may contain embedded typefaces. In accordance with Adobe's licensing policy, this file may be printed or viewed but shall not be edited unless the typefaces which are embedded are licensed to and installed on the computer performing the editing. In downloading this file, parties accept therein the responsibility of not infringing Adobe's licensing policy. The ISO Central Secretariat accepts no liability in this area.

Adobe is a trademark of Adobe Systems Incorporated.

Details of the software products used to create this PDF file can be found in the General Info relative to the file; the PDF-creation parameters were optimized for printing. Every care has been taken to ensure that the file is suitable for use by ISO member bodies. In the unlikely event that a problem relating to it is found, please inform the Central Secretariat at the address given below.

© ISO 2000

All rights reserved. Unless otherwise specified, no part of this publication may be reproduced or utilized in any form or by any means, electronic or mechanical, including photocopying and microfilm, without permission in writing from either ISO at the address below or ISO's member body in the country of the requester.

ISO copyright office
Case postale 56 • CH-1211 Geneva 20
Tel. + 41 22 749 01 11
Fax + 41 22 734 10 79
E-mail copyright@iso.ch
Web www.iso.ch

Printed in Switzerland

Contents

Page

Foreword.....	iv
1 Scope	1
2 Normative reference	1
3 Interchangeability dimensions	2
3.1 Height of fifth wheel of laden tractor	2
3.2 Height of fifth wheel of uncoupled tractor	2
3.3 Forward-clearance-zone radius of semi-trailer	2
3.4 Gooseneck contour	3
4 Operating dimensions	6
4.1 Angles of inclination of semi-trailer in relation to tractor	6
4.2 Lateral inclination	6
4.3 Angle of articulation	6
4.4 Free space between tractor and semi-trailer	7
5 Designation	7
Annex A (normative) Interface specifications for tractors designed for towing high-cube semi-trailers	8

Foreword

ISO (the International Organization for Standardization) is a worldwide federation of national standards bodies (ISO member bodies). The work of preparing International Standards is normally carried out through ISO technical committees. Each member body interested in a subject for which a technical committee has been established has the right to be represented on that committee. International organizations, governmental and non-governmental, in liaison with ISO, also take part in the work. ISO collaborates closely with the International Electrotechnical Commission (IEC) on all matters of electrotechnical standardization.

International Standards are drafted in accordance with the rules given in the ISO/IEC Directives, Part 3.

Draft International Standards adopted by the technical committees are circulated to the member bodies for voting. Publication as an International Standard requires approval by at least 75 % of the member bodies casting a vote.

Attention is drawn to the possibility that some of the elements of this International Standard may be the subject of patent rights. ISO shall not be held responsible for identifying any or all such patent rights.

International Standard ISO 1726 was prepared by Technical Committee ISO/TC 22, *Road Vehicles*, Subcommittee SC 15, *Interchangeability of components of commercial vehicles and buses*.

This third edition cancels and replaces the second edition (ISO 1726:1989), which has been technically revised.

Annex A forms a normative part of this International Standard.

Road vehicles — Mechanical coupling between tractors and semi-trailers — Interchangeability

1 Scope

This International Standard specifies dimensions to ensure interchangeability between a tractor vehicle and a coupled semi-trailer, the two together constituting an articulated vehicle. It specifies certain interchangeability dimensions, including those of the gooseneck contour, as well as operating dimensions related to angle values. The specifications permit the same semi-trailer to be used with either two- or three-axle tractors.

Annex A gives interface technical specifications for tractors designed for towing high-cube semi-trailers, including ISO containers having an external height of 2,9 m.

This International Standard covers articulated vehicles used in commercial cargo transport of the greatest possible variety. However, it may not be applicable to special combination types such as low-bed or tipper vehicles.

This International Standard does not provide limitations of maximum gross mass and overall dimensions, which are generally laid down by legislative requirements.

2 Normative reference

The following normative document contains provisions which, through reference in this text, constitute provisions of this International Standard. For dated references, subsequent amendments to, or revisions of, this publication do not apply. However, parties to agreements based on this International Standard are encouraged to investigate the possibility of applying the most recent edition of the normative document indicated below. For undated references, the latest edition of the normative document referred to applies. Members of ISO and IEC maintain registers of currently valid International Standards.

ISO 337, *Road vehicles — 50 semi-trailer fifth wheel coupling pin — Basic and mounting/interchangeability dimensions*.

3 Interchangeability dimensions

3.1 Height of fifth wheel of laden tractor

The height, h , of the fifth wheel of a laden tractor above the ground reference plane, GRP (see Figure 1), shall be in the range 1 150 mm to 1 300 mm.

3.2 Height of fifth wheel of uncoupled tractor

The height h above GRP of the fifth wheel of an uncoupled tractor shall not exceed 1 400 mm.

3.3 Forward-clearance-zone radius of semi-trailer

The semi-trailer's forward-clearance-zone radius, d (see Figure 2), shall not exceed 2 040 mm.

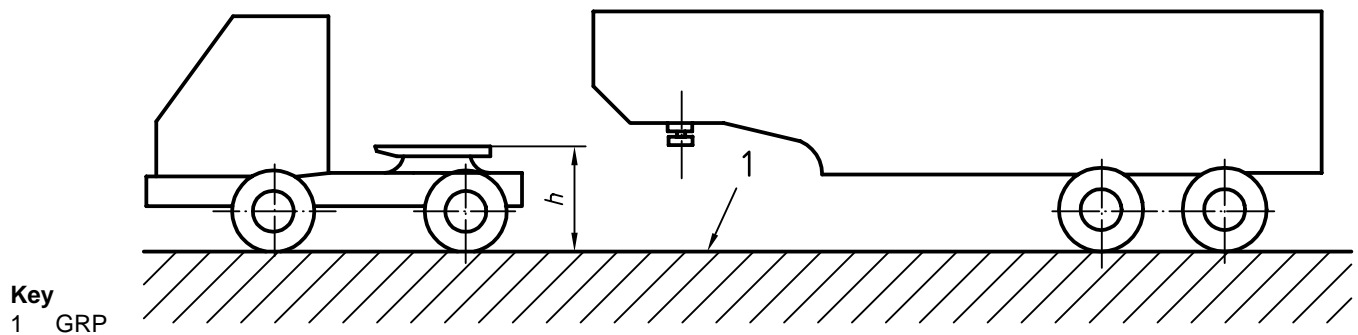
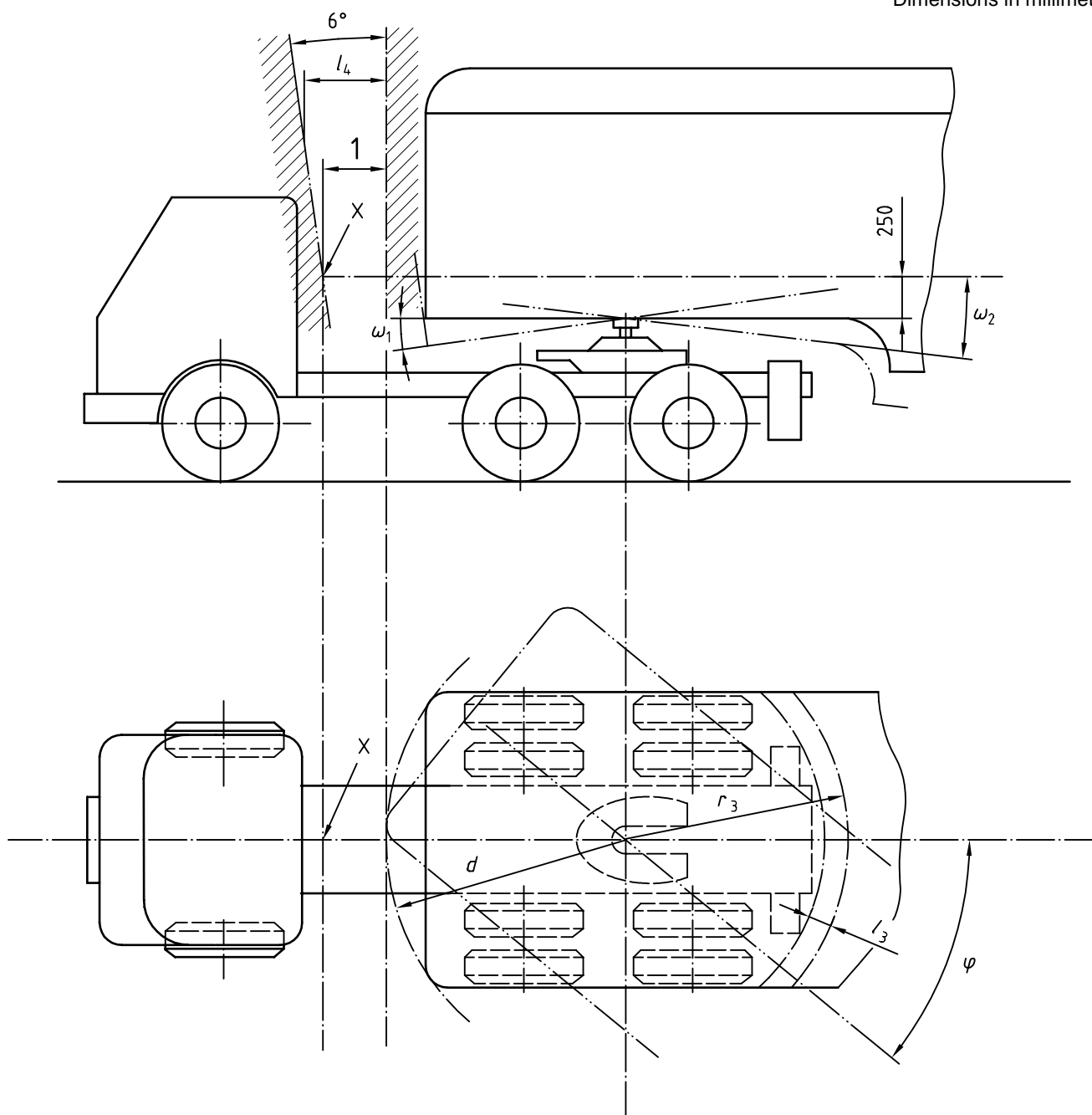

Figure 1 — Height of fifth wheel

Dimensions in millimetres



Key

1 l_4 at point X = 80 mm min

Figure 2 — Free space between tractor and semi-trailer

3.4 Gooseneck contour

The gooseneck shall be located on the outside of a surface consisting of two planes and one surface of revolution interconnected without forming a step. These three parts of the total surface are shown in Figure 3 and defined as follows:

- a plane horizontal and perpendicular to the axis of the coupling pin with a length of l_2 (AB) and a width of that of the semi-trailer, limited by the intersection of
- a second plane of the same width, making an angle γ with the first plane, limited by the intersection of

ISO 1726:2000(E)

- a surface of revolution generated by rotating the vertical portion DE, situated at a radius, r_3 , from the axis of the coupling pin, and an arc of a circle of radius r_2 (CD – C'D'), between the second plane and DE, such that no discontinuity arises.

The values adopted for these generator elements:

- $l_2 = 750$ mm
- $\gamma = 4^\circ$
- $r_2 = 450$ mm
- $r_3 = 2300$ mm

The above dimensions allow the determination of the centre of the circle of radius r_2 .

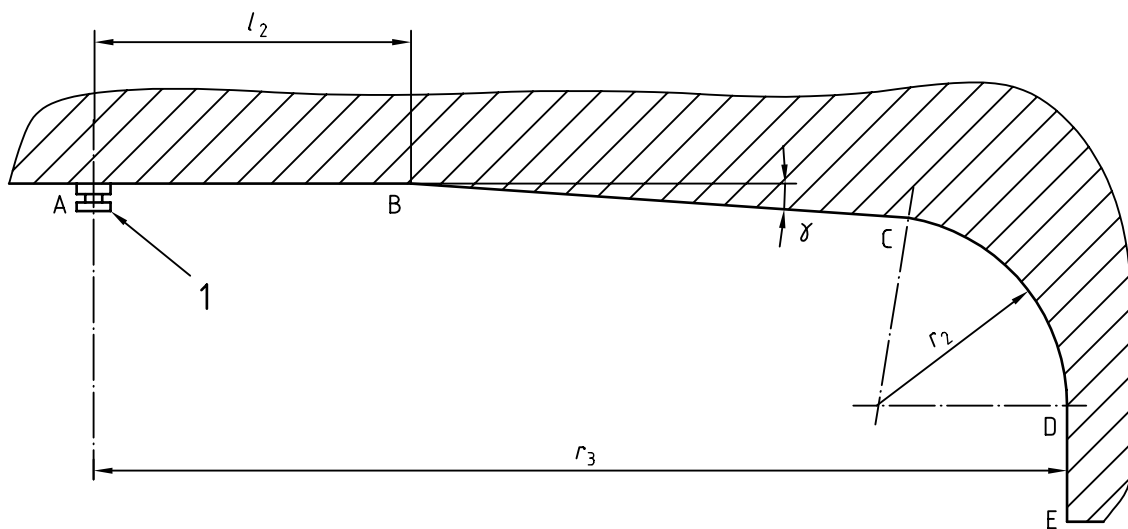

a) Gooseneck contour: generator elements

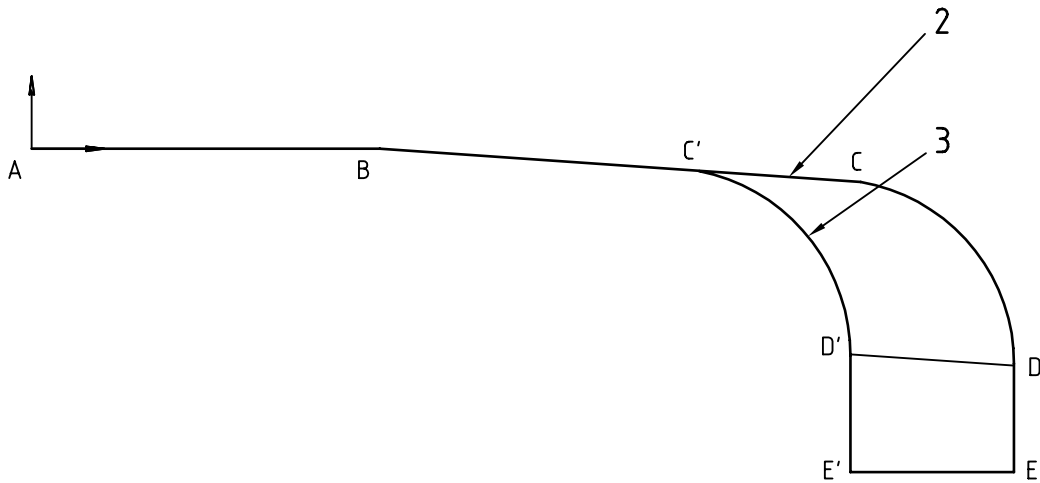

b) Gooseneck contour: centre and outer profiles

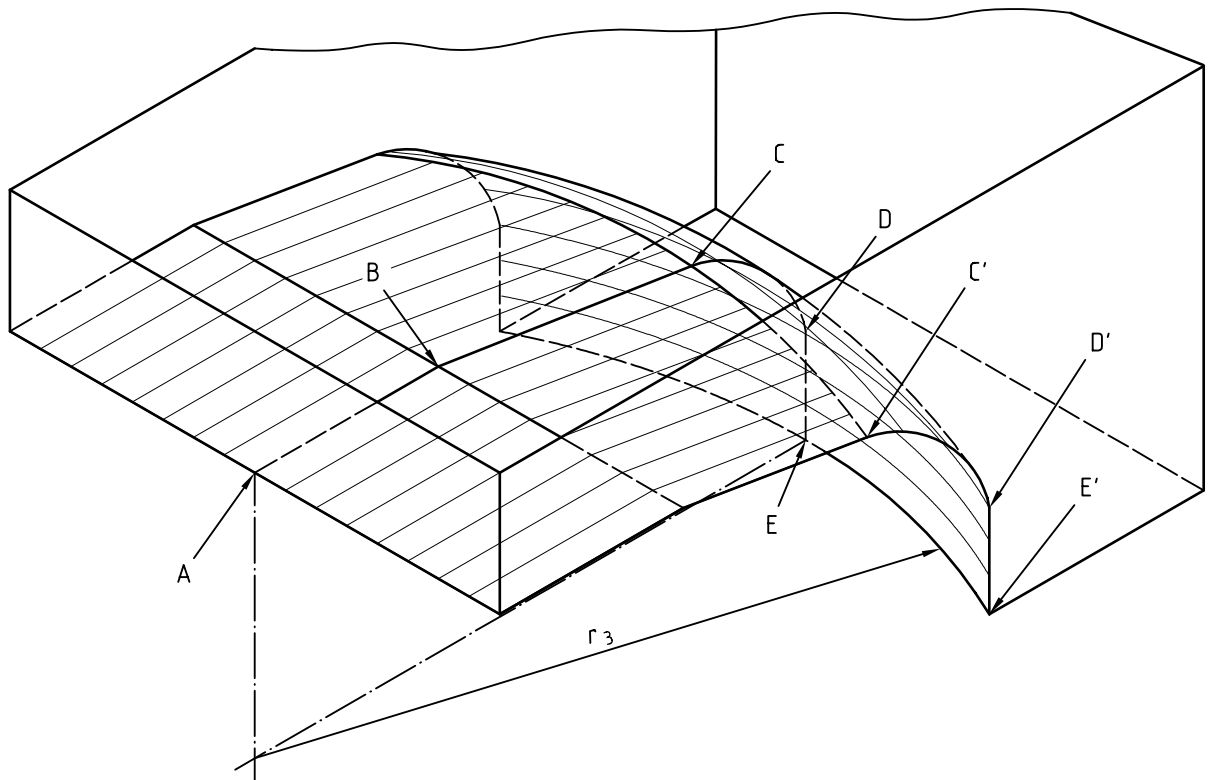

c) Gooseneck contour: three-dimensional view

Key

- 1 Coupling pin (in accordance with ISO 337)
- 2 Centre profile
- 3 Outer profile

Figure 3 — Gooseneck contour

4 Operating dimensions

4.1 Angles of inclination of semi-trailer in relation to tractor

The tractor shall be constructed so that tractor and semi-trailer components, except for those concerned with articulation, do not make contact with each other when the articulated vehicle is running in a straight line, and when the angle of inclination of the semi-trailer relative to the tractor does not exceed the following values (see Figure 2):

- $\omega_1 = 6^\circ$ towards the front;
- $\omega_2 = 7^\circ$ towards the rear.

For the purposes of the measurement of ω_1 and ω_2 , the fifth wheel plate is assumed to be situated in a horizontal plane. The tractor shall be set at the attitude which corresponds to the design laden condition when the tractor is standing on a horizontal plane.

4.2 Lateral inclination

When the trailer is at a lateral inclination, δ (see Figure 4), of a maximum of 3° relative to the tractor chassis, there shall be no contact between the tractor chassis and the semi-trailer.

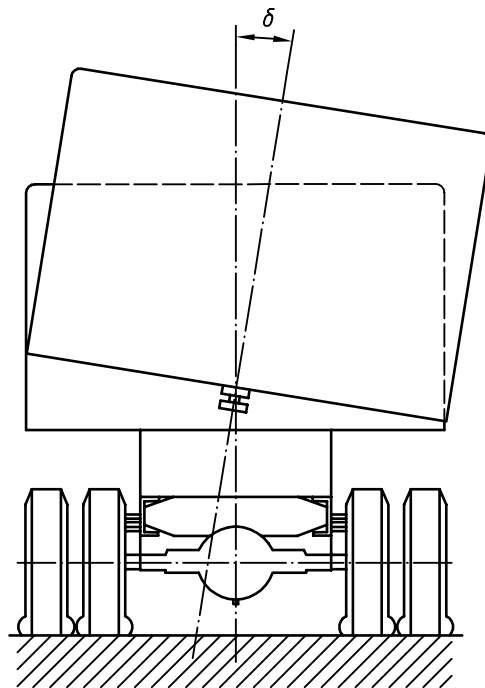

Figure 4 — Lateral inclination

4.3 Angle of articulation

The angle of articulation φ (see Figure 2) is the projection of the angle between the longitudinal axes of the tractor and semi-trailer in the horizontal plane.

The articulation of the vehicle shall be such that no contact is made between the semi-trailer and the tyres or spray-suppression equipment of the tractor, taking into account the maximum value $\omega_2 = 7^\circ$ for all angles φ up to 25° , for both two- and three-axle tractors.

Under manoeuvring conditions, the angle of articulation φ shall be able to reach 90° , with the angle of inclination ω_2 varying from 7° to 3° as φ varies from 25° to 90° .

4.4 Free space between tractor and semi-trailer

The free space between the tractor and semi-trailer is measured as follows (see Figure 2).

- a) l_3 is the distance between two cylinders of revolution, both having the kingpin axis as their axis. One of these cylinders has the radius r_3 (lower part of the gooseneck); the other cylinder is that of the smallest radius within which all points of the rear part of the tractor are located. The distance l_3 shall be a minimum of 100 mm.
- b) l_4 is the horizontal clearance between a cylinder of revolution having as its axis the axis of the fifth wheel coupling and a conical surface of revolution having the same axis. The cylinder of revolution has the radius d . The conical surface is generated by a line making an angle of 6° from the vertical towards the front of the tractor. This line is positioned in such a way that the conical surface does not interfere with any point of the tractor located above the fifth-wheel coupling horizontal plane. A point, X, of this surface is positioned on the plane of symmetry of the semi-trailer at a height of 250 mm above the fifth wheel coupling face. At X, l_4 shall be a minimum of 80 mm.

5 Designation

Tractors and semi-trailers in compliance with the requirements of this International Standard (excluding annex A) shall be designated:

Tractors and semi-trailers ISO 1726-S

Tractors and semi-trailers in compliance with annex A of this International Standard shall be designated:

Tractors and semi-trailers ISO 1726-A

Annex A
(normative)

Interface specifications for tractors designed for towing high-cube semi-trailers

For tractors designed to tow high-cube semi-trailers, including ISO containers having an external height of 2,9 m, the requirements in stead of those stated in 3.1 and 3.2 of this International Standard are:

- the height h above GRP of the fifth wheel of a laden tractor shall be in the range 1 025 mm to 1 100 mm;
- the height h above GRP of the fifth wheel of an uncoupled tractor shall not exceed 1 150 mm.

Although three-axle tractors are not excluded from annex A, it might be difficult to apply its specifications and at the same time comply with the angles of inclination and other requirements specified elsewhere in this International Standard. Any deviations from compliance should be carefully evaluated by those competent to do so in order to decide whether safe and satisfactory operation can be ensured.

ISO 1726:2000(E)

ICS 43.040.70

Price based on 8 pages

© ISO 2000 – All rights reserved