**Road vehicles — Mechanical couplings
between tractors and semi-trailers —**

**Part 2:
Interchangeability between low-coupling
tractors and high-volume semi-trailers**

Véhicules routiers — Liaisons mécaniques entre tracteurs et semi-remorques —

Partie 2: Interchangeabilité entre tracteurs avec accouplement bas et semi-remorques de grand volume



Reference number
ISO 1726-2:2007(E)

© ISO 2007

PDF disclaimer

This PDF file may contain embedded typefaces. In accordance with Adobe's licensing policy, this file may be printed or viewed but shall not be edited unless the typefaces which are embedded are licensed to and installed on the computer performing the editing. In downloading this file, parties accept therein the responsibility of not infringing Adobe's licensing policy. The ISO Central Secretariat accepts no liability in this area.

Adobe is a trademark of Adobe Systems Incorporated.

Details of the software products used to create this PDF file can be found in the General Info relative to the file; the PDF-creation parameters were optimized for printing. Every care has been taken to ensure that the file is suitable for use by ISO member bodies. In the unlikely event that a problem relating to it is found, please inform the Central Secretariat at the address given below.



COPYRIGHT PROTECTED DOCUMENT

© ISO 2007

All rights reserved. Unless otherwise specified, no part of this publication may be reproduced or utilized in any form or by any means, electronic or mechanical, including photocopying and microfilm, without permission in writing from either ISO at the address below or ISO's member body in the country of the requester.

ISO copyright office
Case postale 56 • CH-1211 Geneva 20
Tel. + 41 22 749 01 11
Fax + 41 22 749 09 47
E-mail copyright@iso.org
Web www.iso.org

Published in Switzerland

Foreword

ISO (the International Organization for Standardization) is a worldwide federation of national standards bodies (ISO member bodies). The work of preparing International Standards is normally carried out through ISO technical committees. Each member body interested in a subject for which a technical committee has been established has the right to be represented on that committee. International organizations, governmental and non-governmental, in liaison with ISO, also take part in the work. ISO collaborates closely with the International Electrotechnical Commission (IEC) on all matters of electrotechnical standardization.

International Standards are drafted in accordance with the rules given in the ISO/IEC Directives, Part 2.

The main task of technical committees is to prepare International Standards. Draft International Standards adopted by the technical committees are circulated to the member bodies for voting. Publication as an International Standard requires approval by at least 75 % of the member bodies casting a vote.

Attention is drawn to the possibility that some of the elements of this document may be the subject of patent rights. ISO shall not be held responsible for identifying any or all such patent rights.

ISO 1726-2 was prepared by Technical Committee ISO/TC 22, *Road vehicles*, Subcommittee SC 15, *Interchangeability of components of commercial vehicles and buses*.

ISO 1726 consists of the following parts, under the general title *Road vehicles — Mechanical couplings between tractors and semi-trailers*:

- *Part 1: Interchangeability between tractors and semi-trailers for general cargo*¹⁾
- *Part 2: Interchangeability between low-coupling tractors and high-volume semi-trailers*

1) Revision of ISO 1726:2000.

Road vehicles — Mechanical couplings between tractors and semi-trailers —

Part 2: Interchangeability between low-coupling tractors and high-volume semi-trailers

1 Scope

This part of ISO 1726 specifies dimensions to ensure interchangeability between a low coupling height tractor vehicle and a coupled high-volume semi-trailer, the two together constituting a high-volume articulated vehicle. It specifies certain interchangeability dimensions, including those of the optimised gooseneck contour, as well as operating dimensions related to angle values. The specifications are primarily intended to permit semi-trailers to be coupled with two-axle tractors. However, three-axle tractors are not excluded, provided they are in compliance with the requirements of this part of ISO 1726.

This part of ISO 1726 does not provide limitations of maximum gross mass and overall dimensions, which are generally laid down by legislative requirements.

2 Interchangeability dimensions

2.1 Height of fifth wheel of a laden tractor

The height, h , of the fifth wheel of a laden low-coupling tractor above ground (see Figure 1) shall be in the range 900 mm to 975 mm.

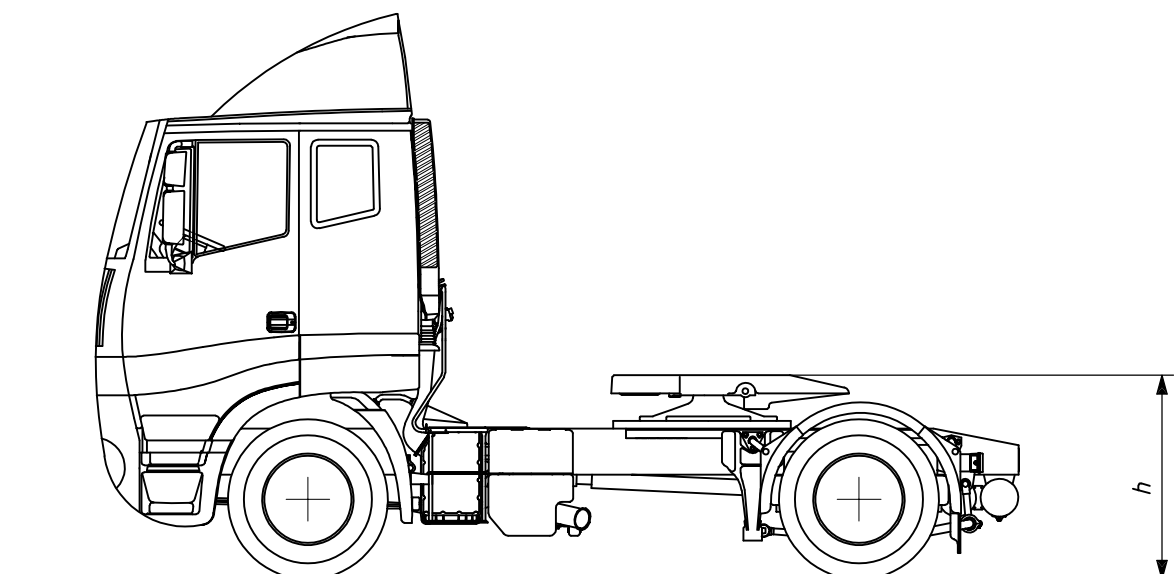

Key

h height of fifth wheel

Figure 1 — Height of fifth wheel

2.2 Height of fifth wheel of an uncoupled tractor

The height, h , of the fifth wheel of an uncoupled low-coupling tractor shall not exceed 1 000 mm.

2.3 Forward clearance zone radius of a semi-trailer

The front end of the semi-trailer (see Figure 2) shall not exceed the radius, r_1 , of 2 040 mm.

Dimensions in millimetres

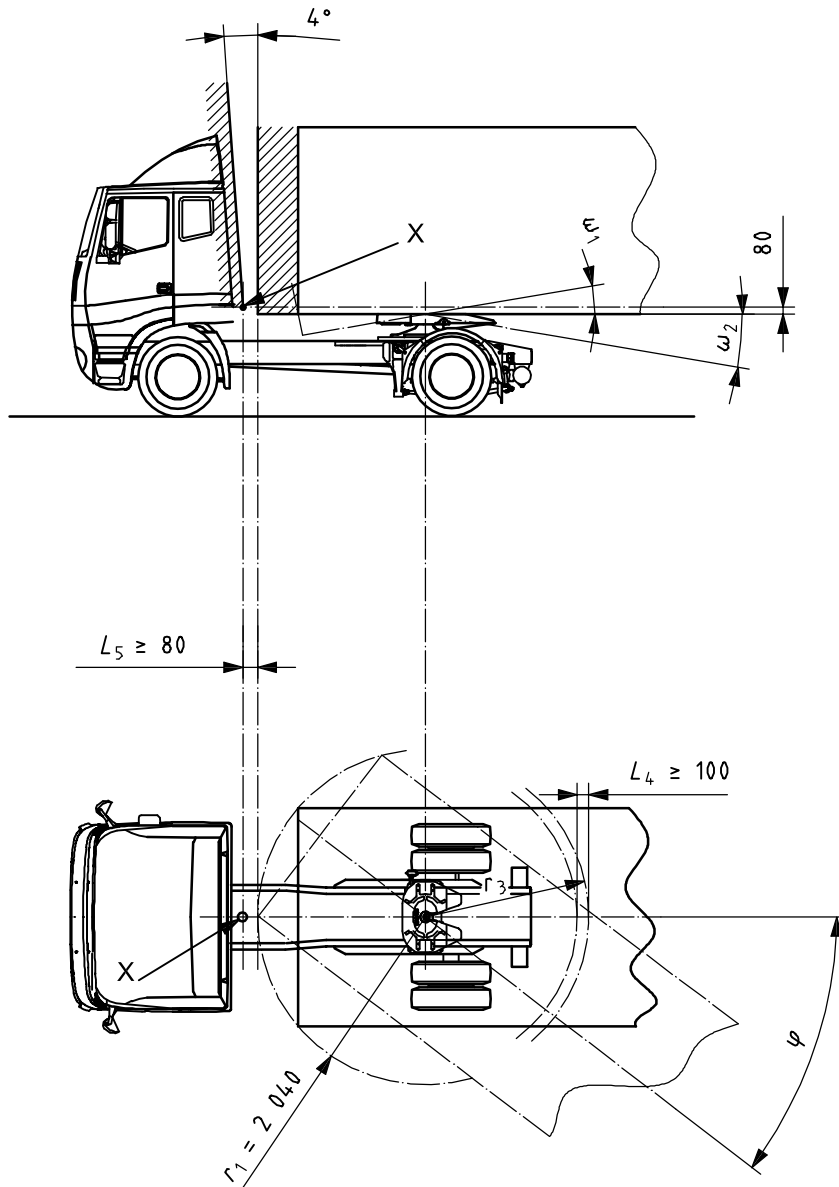

Key

- L_4 distance between two cylinders of revolution [see 3.4 a)]
- L_5 distance between surface of cylinder of revolution and conical surface of revolution [see 3.4 b)]
- r_1 forward clearance zone radius of semi-trailer (see 2.3)
- r_3 radius between axis of coupling pin and lower part of the semi-trailer gooseneck [see 2.4 d)]
- ω_1 angle of inclination towards the front
- ω_2 angle of inclination towards the rear
- φ angle of articulation

Figure 2 — Free space between tractor and semi-trailer

2.4 Gooseneck contour

The gooseneck shall be located on the outside of a surface consisting of different planes and one surface of revolution specified below, which are interconnected one to the next without forming a step, as shown in Figures 3 a) and 3 b).

These parts of the total surface are defined as follows:

- a) a first plane, AB, horizontal and perpendicular to the axis of the coupling pin (kingpin) with a length of L_1 and a width the same as the semi-trailer, limited by the intersection of a second plane, described in b);
- b) a second plane, BC, with a width the same as the semi-trailer, making an angle γ_1 with the first plane, limited by the intersection of a third plane, described in c);
- c) a third plane, CD, with a width the same as the semi-trailer, making an angle γ_2 with the first plane, limited by the intersection of a surface of revolution, described in d);
- d) a surface of revolution, generated by rotating the vertical portion, EF, situated at a radius r_3 from the axis of the coupling pin (kingpin), and an arc of a circle of radius r_2 (DE) between the third plane and the vertical portion, EF, such that no discontinuity arises;
- e) a fourth plane, AU, situated towards the front end of the semi-trailer, horizontal and perpendicular to the axis of the coupling pin (kingpin), with a length L_3 and a width the same as the semi-trailer, limited by the intersection of an inclined plane, UV, making an angle α with the horizontal; the extremity of the front end (V) shall not protrude beyond a surface of revolution generated by a vertical plane at radius $r_1 = 2\,040$ mm from the axis of the coupling pin (kingpin).

The values adopted for these elements of the generator are as follows:

length of first plane, $L_1 = 500$ mm

length of first and second planes combined, $L_2 = 1\,350$ mm

length of fourth plane, $L_3 = 1\,800$ mm

radius of arc between third plane and vertical portion, $r_2 = 450$ mm

radius between axis of coupling pin (kingpin) and vertical portion, $r_3 = 2\,100$ mm

angle between second plane and first plane, $\gamma_1 = 1^\circ$

angle between third plane and first plane, $\gamma_2 = 7^\circ$

angle between inclined plane and the horizontal, $\alpha \geq 3,5^\circ$

The centre of the circle of radius r_2 is determined on the basis of these dimensions.

A-A

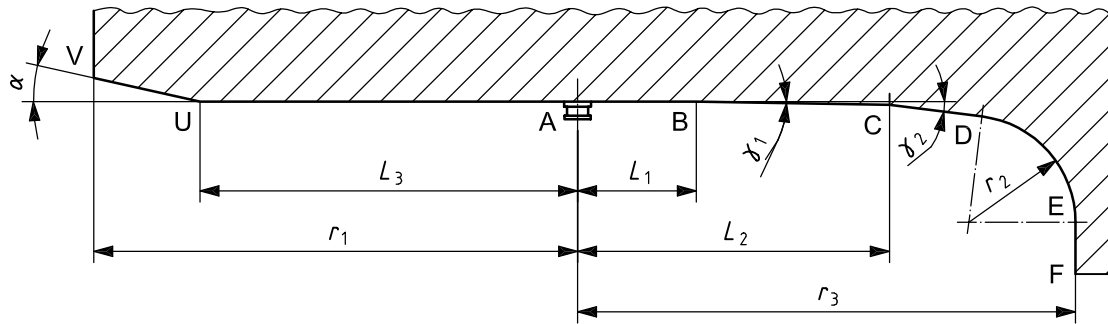

a) Generator elements

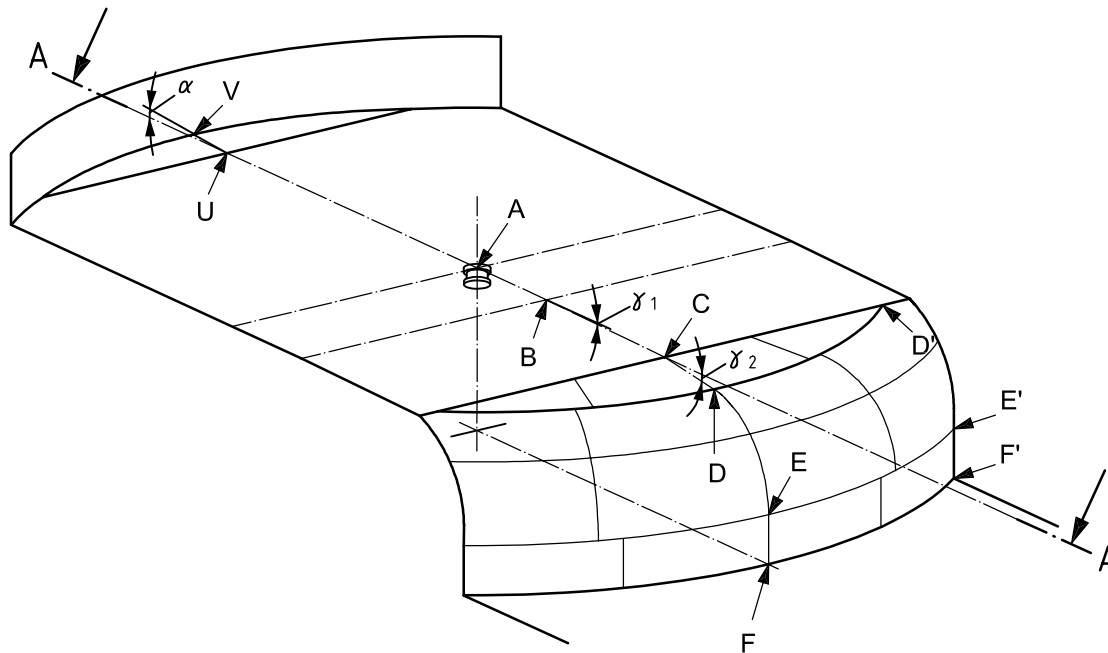

b) 3-dimensional view

Key

- L_1 length of first plane (AB)
- L_2 length of first and second planes combined (AB and BC)
- L_3 length of fourth plane (AU)
- r_1 radius of cylinder of revolution at the front end = 2 040
- r_2 radius of arc (DE)
- r_3 radius between coupling pin (kingpin) axis and vertical portion (EF)
- α angle between inclined plane (UV) and the horizontal
- γ_1 angle between second plane (BC) and first plane (AB)
- γ_2 angle between third plane (CD) and first plane (AB)

Figure 3 — Optimized gooseneck contour

3 Operating dimensions

3.1 Angles of inclination of the semi-trailer in relation to the tractor

The tractor shall be so constructed that the tractor and the semi-trailer components, except for those concerned with articulation, do not make contact with each other when the articulated vehicle is running in a straight line, when the angle of inclination of the semi-trailer relative to the tractor does not exceed the values shown below (see Figure 2):

angle of inclination towards the front, $\omega_1 \leq 3,5^\circ$;

angle of inclination towards the rear, $\omega_2 \leq 4,5^\circ$.

For the purposes of the measurement of ω_1 and ω_2 , the fifth wheel plate is assumed to be situated in a horizontal plane. The tractor shall be set at the attitude which corresponds to the design laden condition when the tractor is standing on a horizontal plane.

3.2 Lateral inclination

When the semi-trailer is at a lateral inclination, δ , of a maximum of 2° relative to the tractor chassis (see Figure 4), there shall be no contact between the tractor chassis and the semi-trailer.

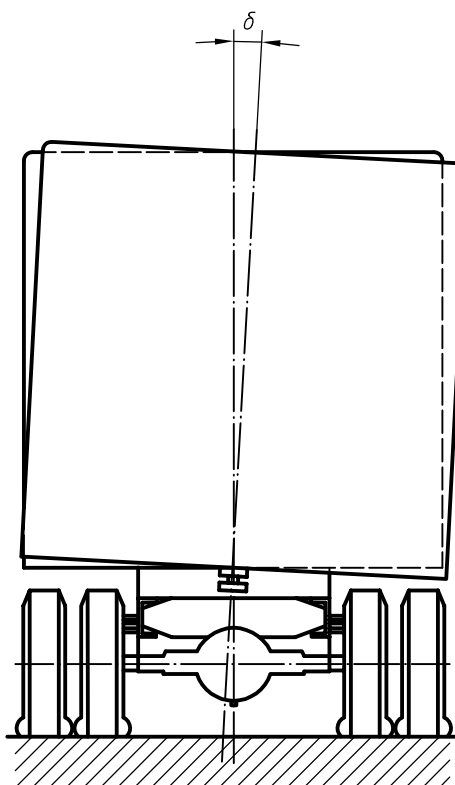

Key

δ lateral inclination

Figure 4 — Lateral inclination

3.3 Angle of articulation

The angle of articulation, φ , is the projection of the angle between the longitudinal axes of the tractor and semi-trailer in the horizontal plane (see Figure 2).

The articulation of the vehicle shall be such that no contact is made between the semi-trailer and the tyres or spray suppression equipment of the tractor, taking into account that $\omega_2 \leq 4,5^\circ$ for all angles of $\varphi \leq 25^\circ$.

Under manoeuvring conditions, the angle of articulation, φ , shall be able to reach 90° and the maximum angle of inclination, ω_2 , may vary from $4,5^\circ$ to 3° as φ varies from 25° to 90° .

3.4 Free space between the tractor and the semi-trailer

The free space between the tractor and semi-trailer is measured as follows (see Figure 2).

- a) L_4 is the distance between two cylinders of revolution, both having the kingpin (coupling pin) axis as their axis. One of these cylinders has radius r_3 (lower part of the gooseneck) and the other is the cylinder of smallest radius within which all points of the rear part of the tractor are located. $L_4 \geq 100$ mm.
- b) L_5 is the clearance between the surface of the cylinder of revolution, whose axis is the axis of the fifth wheel coupling and whose radius, r_1 , is 2 040 mm, and a conical surface of revolution which has the same axis. This conical surface is generated by a line making an angle of 4° from the vertical towards the front of the tractor. A point, X, of this surface is positioned on the plane of symmetry of the semi-trailer at a height 80 mm above the fifth wheel coupling face. At this point, $L_5 \geq 80$ mm.

4 Designation

Low-coupling tractors and high-volume semi-trailers in compliance with the requirements of this part of ISO 1726 shall be designated as follows:

Tractor ISO 1726 - L

Semi-trailer ISO 1726 - L

where

L means "low coupling height".

Bibliography

- [1] ISO 337, *Road vehicles — 50 semi-trailer fifth wheel coupling pin — Basic and mounting/interchangeability dimensions*

ICS 43.040.70

Price based on 7 pages