

---

---

**Assembly tools for screws and nuts —  
Technical specifications —**

Part 2:  
**Machine-operated sockets (impact)**

*Outils de manoeuvre pour vis et écrous — Spécifications techniques —  
Partie 2: Douilles à machine (impact)*



**COPYRIGHT PROTECTED DOCUMENT**

© ISO 2016, Published in Switzerland

All rights reserved. Unless otherwise specified, no part of this publication may be reproduced or utilized otherwise in any form or by any means, electronic or mechanical, including photocopying, or posting on the internet or an intranet, without prior written permission. Permission can be requested from either ISO at the address below or ISO's member body in the country of the requester.

ISO copyright office  
Ch. de Blandonnet 8 • CP 401  
CH-1214 Vernier, Geneva, Switzerland  
Tel. +41 22 749 01 11  
Fax +41 22 749 09 47  
copyright@iso.org  
www.iso.org

# Contents

	Page
<b>Foreword</b> .....	<b>iv</b>
<b>Introduction</b> .....	<b>v</b>
<b>1 Scope</b> .....	<b>1</b>
<b>2 Normative references</b> .....	<b>1</b>
<b>3 Terms and definitions</b> .....	<b>1</b>
<b>4 Test torsion torques</b> .....	<b>1</b>
<b>5 Materials</b> .....	<b>2</b>
<b>6 Hardness testing</b> .....	<b>2</b>
<b>7 Torque testing</b> .....	<b>2</b>
7.1 Method .....	<b>2</b>
7.2 Test of machine-operated square drive sockets .....	<b>3</b>
<b>Bibliography</b> .....	<b>6</b>

## Foreword

ISO (the International Organization for Standardization) is a worldwide federation of national standards bodies (ISO member bodies). The work of preparing International Standards is normally carried out through ISO technical committees. Each member body interested in a subject for which a technical committee has been established has the right to be represented on that committee. International organizations, governmental and non-governmental, in liaison with ISO, also take part in the work. ISO collaborates closely with the International Electrotechnical Commission (IEC) on all matters of electrotechnical standardization.

The procedures used to develop this document and those intended for its further maintenance are described in the ISO/IEC Directives, Part 1. In particular the different approval criteria needed for the different types of ISO documents should be noted. This document was drafted in accordance with the editorial rules of the ISO/IEC Directives, Part 2 (see [www.iso.org/directives](http://www.iso.org/directives)).

Attention is drawn to the possibility that some of the elements of this document may be the subject of patent rights. ISO shall not be held responsible for identifying any or all such patent rights. Details of any patent rights identified during the development of the document will be in the Introduction and/or on the ISO list of patent declarations received (see [www.iso.org/patents](http://www.iso.org/patents)).

Any trade name used in this document is information given for the convenience of users and does not constitute an endorsement.

For an explanation on the meaning of ISO specific terms and expressions related to conformity assessment, as well as information about ISO's adherence to the World Trade Organization (WTO) principles in the Technical Barriers to Trade (TBT) see the following URL: [www.iso.org/iso/foreword.html](http://www.iso.org/iso/foreword.html).

The committee responsible for this document is ISO/TC 29, *Small tools*, Subcommittee SC 10, *Assembly tools for screws and nuts, pliers and nippers*.

This third edition cancels and replaces the second edition (ISO 1711-2:2015), which has been technically revised with the following changes:

- [Clause 4](#) has been added, giving empiric formulae for minimum test torsion torques as a function of width across flats;
- in [7.1](#) the angle chamfer  $\alpha$  of the test mandrel in [Figure 1](#) has been changed from  $30^\circ \text{ max}$  to  $15^\circ \leq \alpha \leq 30^\circ$ ;
- revision of sizes for width across flats covered in [Table 3](#); Sizes 3,5, 4,5, 26 and 28 have been deleted;
- revision of minimum test torque values in [Table 3](#).

A list of all parts in the ISO 1711 series can be found on the ISO website.

## Introduction

When testing machine-operated impact sockets, there are three types of testing that could be relevant:

- torsional testing;
- impact testing;
- endurance testing.

This document covers only torsional testing of machine-operated sockets. Presently, the torsional test and hardness values given in this document ensure sockets will last a reasonable impact life if the appropriate tool is used.

An impact test or endurance test is desired, but at present, there is no procedure suitable for standardization available. This will be an issue for a future revision of this document.



# Assembly tools for screws and nuts — Technical specifications —

## Part 2: Machine-operated sockets (impact)

### 1 Scope

This document specifies hardness and minimum torsional strength for machine-operated square drive sockets in accordance with ISO 2725-2 intended for use with impact wrenches.

EXAMPLE Reference nos. 2 2 02 01 0; 2 2 02 02 0; 5 2 00 04 0.

NOTE The sockets mentioned above are listed under their respective reference numbers in ISO 1703.

### 2 Normative references

The following documents are referred to in the text in such a way that some or all of their content constitutes requirements of this document. For dated references, only the edition cited applies. For undated references, the latest edition of the referenced document (including any amendments) applies.

ISO 6508-1, *Metallic materials — Rockwell hardness test — Part 1: Test method*

### 3 Terms and definitions

No terms and definitions are listed in this document.

ISO and IEC maintain terminological databases for use in standardization at the following addresses:

- IEC Electropedia: available at <http://www.electropedia.org/>
- ISO Online browsing platform: available at <http://www.iso.org/obp>

### 4 Test torsion torques

The empiric formulae giving minimum test torsion torques,  $M$ , in newton metres, as a function of width across flats,  $s$ , in millimetres, are given for information in [Table 1](#).

The minimum test torsion torques to be applied are given in [Table 3](#).

**Table 1 — Formulae giving minimum test torsion torques**

Nominal dimension for driving square	Minimum test torsion torque $M$ N · m
6,3	$s^{1,7}$
10	$0,6 \cdot s^{2,3}$
12,5	$1,85 \cdot s^2$

**Table 1** (continued)

20	$6,5 \cdot s^{1,85}$
25	$70 \cdot s^{1,2}$
40	$48 \cdot s^{1,5}$

## 5 Materials

Sockets, driving squares and all accessories shall be manufactured from steel.

The chemical composition and heat treatment shall be to produce tools conforming to requirements specified hereinafter.

## 6 Hardness testing

The hardness test shall be carried out in accordance with ISO 6508-1.

Sockets and attachments shall be hardened and tempered to Rockwell hardness values given in [Table 2](#).

**Table 2 — Rockwell hardness values for machine-operated sockets as function of driving square and hexagon width across flats,  $s^a$**

Hardness HRC	Driving square nominal size <sup>b</sup>					
	6,3	10	12,5	20	25	40
40 to 48	$3,2 \leq s \leq 16$	$7 \leq s \leq 14$	$8 \leq s \leq 14$	—	—	—
38 to 46	—	$15 \leq s \leq 24$	$15 \leq s \leq 34$	$17 \leq s \leq 60$	$27 \leq s \leq 70$	$36 \leq s \leq 70$
<sup>a</sup> Width across flats $s$ are according to ISO 272. <sup>b</sup> For dimensions of driving squares, see ISO 1174-2.						

## 7 Torque testing

### 7.1 Method

The minimum test torsion torque values to be applied are given in [Table 3](#).

The socket shall be fully engaged in a hexagon test mandrel as shown in [Figure 1](#). The height,  $h$ , and the width across corners,  $e_{min}$ , of the mandrel are specified in [Table 3](#). The angle of the chamfer  $\alpha$  shall be between 15° and 30°.

Smoothly apply the load until the minimum testing torque as given in [Table 3](#) is reached.

The nominal across-flats dimension of the test mandrel shall be equal to the nominal dimension,  $s$ , with a tolerance of h8. The mandrel shall be hardened to not less than hardness 55 HRC.

A device in which the mandrel can be rotated at a certain torque determined with an accuracy of  $\pm 2,5$  % can also be used for this test.

Following the application of the minimum test torsion torque, any possible damage or deformation shall not affect the usability of the tool.

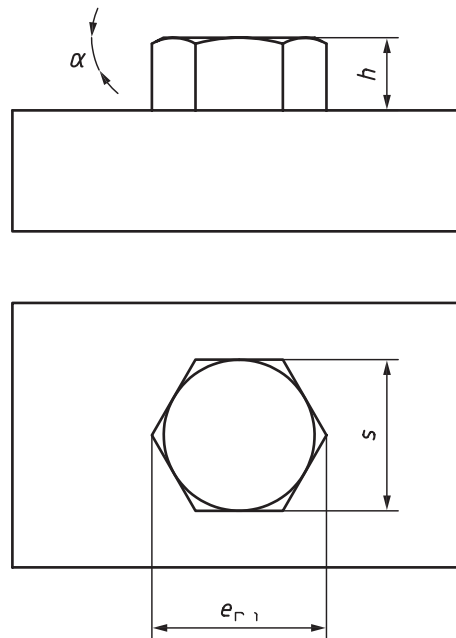

**Key**

$\alpha$  angle of the chamfer,  $15^\circ \leq \alpha \leq 30^\circ$

$e_{\min}$  width across corners

$h$  test mandrel height

$s$  width across flats

NOTE The use of the  $30^\circ$  chamfer will reduce the effective engagement which might affect the ultimate test torque.

**Figure 1 — Test mandrel height,  $h$ , and width across flats,  $s$**

## 7.2 Test of machine-operated square drive sockets

A square mandrel of hardness not less than 55 HRC shall be used for driving the socket for nominal width across flats 22 mm and smaller. A square mandrel of hardness not less than 50 HRC shall be used for driving the socket for nominal width across flats 24 mm and larger. The nominal width across-flats dimension of this mandrel shall be equal to the maximum dimension, with a tolerance of h8, of the corresponding square drive.

The axis of the two mandrels and the axis of the socket shall remain coaxial during the test.

Table 3 — Minimum test torsion torque and test mandrel height as a function of width across flats

Nominal width across flats <i>s</i>	Minimum test torsion torque <sup>b</sup> <i>M</i> N·m						Test mandrel mm	
	Driving square nominal size <sup>c</sup>						Height <i>h</i> <i>h</i> <sub>13</sub>	Width across corners <sup>e</sup> <i>e</i> <sub>min</sub>
	6,3	10	12,5	20	25	40		
3,2	7,2	—	—	—	—	—	1,3	3,62
4	10,6	—	—	—	—	—	1,6	4,52
5	15,4	—	—	—	—	—	2	5,65
5,5	18,1	—	—	—	—	—	2,4	6,22
6 <sup>a</sup>	21,0	37	—	—	—	—	2,8	6,78
7	27,3	53	—	—	—	—	3,2	7,91
8	34,3	72	118	—	—	—	4	9,04
9 <sup>a</sup>	41,9	94	150	—	—	—	4,4	10,17
10	50,1	120	185	—	—	—	4,8	11,30
11	58,9	149	224	—	—	—	5,6	12,43
12 <sup>a</sup>	68,3	182	266	—	—	—	6	13,56
13	75,0 <sup>d</sup>	219	313	—	—	—	6,4	14,69
14 <sup>a</sup>	75,0 <sup>d</sup>	260	363	—	—	—	7	15,82
15	75,0 <sup>d</sup>	280 <sup>d</sup>	416	—	—	—	7,4	16,95
16	75,0 <sup>d</sup>	280 <sup>d</sup>	474	—	—	—	8	18,08
17 <sup>a</sup>	75,0 <sup>d</sup>	280 <sup>d</sup>	535	—	—	—	8,8	19,21
18	—	280 <sup>d</sup>	599	—	—	—	9,6	20,34
19 <sup>a</sup>	—	280 <sup>d</sup>	650 <sup>d</sup>	—	—	—	10,2	21,47
20 <sup>a</sup>	—	280 <sup>d</sup>	650 <sup>d</sup>	—	—	—	10,7	22,6
21	—	280 <sup>d</sup>	650 <sup>d</sup>	1 816	—	—	11,2	23,73
22 <sup>a</sup>	—	280 <sup>d</sup>	650 <sup>d</sup>	1 979	—	—	11,8	24,86
23 <sup>a</sup>	—	280 <sup>d</sup>	650 <sup>d</sup>	2 148	—	—	12,3	25,99
24	—	280 <sup>d</sup>	650 <sup>d</sup>	2 200 <sup>d</sup>	—	—	12,8	27,12
25 <sup>a</sup>	—	280 <sup>d</sup>	650 <sup>d</sup>	2 200 <sup>d</sup>	—	—	13,3	28,25
27	—	—	650 <sup>d</sup>	2 200 <sup>d</sup>	3 654	—	14,4	30,51
30	—	—	650 <sup>d</sup>	2 200 <sup>d</sup>	4 000 <sup>d</sup>	—	16	33,90
32 <sup>a</sup>	—	—	650 <sup>d</sup>	2 200 <sup>d</sup>	4 000 <sup>d</sup>	—	16,8	36,16
34	—	—	650 <sup>d</sup>	2 200 <sup>d</sup>	4 000 <sup>d</sup>	—	17,6	38,42
36	—	—	—	2 200 <sup>d</sup>	4 000 <sup>d</sup>	10 368	19,2	40,68
41	—	—	—	2 200 <sup>d</sup>	4 000 <sup>d</sup>	12 601	21,6	46,33
46	—	—	—	2 200 <sup>d</sup>	4 000 <sup>d</sup>	14 975	24	51,98
50	—	—	—	2 200 <sup>d</sup>	4 000 <sup>d</sup>	15 100 <sup>d</sup>	26,4	56,50
55	—	—	—	2 200 <sup>d</sup>	4 000 <sup>d</sup>	15 100 <sup>d</sup>	28,8	62,15

<sup>a</sup> Not according to ISO 272.

<sup>b</sup> Hexagons larger than tabled sizes are required to pass the highest tabled test torsion torque value shown for the applicable driving square.

<sup>c</sup> In accordance with ISO 1174-2.

<sup>d</sup> The test torsion torque values have been limited due to the strength of the driving square for that hexagon size.

<sup>e</sup>  $e_{min} = s_{nom} \times 1,13$  values of  $e_{min}$  are rounded with two decimals.

Table 3 (continued)

Nominal width across flats $s$	Minimum test torsion torque <sup>b</sup> $M$ N·m						Test mandrel mm	
	Driving square nominal size <sup>c</sup>						Height $h$ $h_{13}$	Width across corners <sup>e</sup> $e_{min}$
	6,3	10	12,5	20	25	40		
60	—	—	—	2 200 <sup>d</sup>	4 000 <sup>d</sup>	15 100 <sup>d</sup>	31,2	67,80
65	—	—	—	—	4 000 <sup>d</sup>	15 100 <sup>d</sup>	33,6	73,45
70	—	—	—	—	4 000 <sup>d</sup>	15 100 <sup>d</sup>	36	79,10

<sup>a</sup> Not according to ISO 272.

<sup>b</sup> Hexagons larger than tabled sizes are required to pass the highest tabled test torsion torque value shown for the applicable driving square.

<sup>c</sup> In accordance with ISO 1174-2.

<sup>d</sup> The test torsion torque values have been limited due to the strength of the driving square for that hexagon size.

<sup>e</sup>  $e_{min} = s_{nom} \times 1,13$  values of  $e_{min}$  are rounded with two decimals.

## Bibliography

- [1] ISO 272, *Fasteners — Hexagon products — Widths across flats*
- [2] ISO 1174-2, *Assembly tools for screws and nuts — Driving squares — Part 2: Driving squares for power socket tools*
- [3] ISO 1703, *Assembly tools for screws and nuts — Designation and nomenclature*
- [4] ISO 2725-2, *Assembly tools for screws and nuts — Square drive sockets — Part 2: Machine-operated sockets ("impact")*



