**Rubber latex — Determination of
apparent viscosity by the Brookfield test
method**

*Latex de caoutchouc — Détermination de la viscosité apparente par la
méthode d'essai de Brookfield*



Reference number
ISO 1652:2011(E)

© ISO 2011

PDF disclaimer

This PDF file may contain embedded typefaces. In accordance with Adobe's licensing policy, this file may be printed or viewed but shall not be edited unless the typefaces which are embedded are licensed to and installed on the computer performing the editing. In downloading this file, parties accept therein the responsibility of not infringing Adobe's licensing policy. The ISO Central Secretariat accepts no liability in this area.

Adobe is a trademark of Adobe Systems Incorporated.

Details of the software products used to create this PDF file can be found in the General Info relative to the file; the PDF-creation parameters were optimized for printing. Every care has been taken to ensure that the file is suitable for use by ISO member bodies. In the unlikely event that a problem relating to it is found, please inform the Central Secretariat at the address given below.



COPYRIGHT PROTECTED DOCUMENT

© ISO 2011

All rights reserved. Unless otherwise specified, no part of this publication may be reproduced or utilized in any form or by any means, electronic or mechanical, including photocopying and microfilm, without permission in writing from either ISO at the address below or ISO's member body in the country of the requester.

ISO copyright office
Case postale 56 • CH-1211 Geneva 20
Tel. + 41 22 749 01 11
Fax + 41 22 749 09 47
E-mail copyright@iso.org
Web www.iso.org

Published in Switzerland

Contents

Page

| | |
|--|-----------|
| Foreword | iv |
| 1 Scope | 1 |
| 2 Normative references | 1 |
| 3 Terms and definitions | 1 |
| 4 Principle | 1 |
| 5 Apparatus | 2 |
| 6 Sampling | 2 |
| 7 Further preparation of test sample | 4 |
| 8 Procedure | 4 |
| 9 Expression of results | 5 |
| 10 Precision | 5 |
| 11 Test report | 5 |
| Annex A (informative) Viscosity-measurement methods | 6 |
| Annex B (informative) Precision statement | 7 |
| Bibliography | 9 |

Foreword

ISO (the International Organization for Standardization) is a worldwide federation of national standards bodies (ISO member bodies). The work of preparing International Standards is normally carried out through ISO technical committees. Each member body interested in a subject for which a technical committee has been established has the right to be represented on that committee. International organizations, governmental and non-governmental, in liaison with ISO, also take part in the work. ISO collaborates closely with the International Electrotechnical Commission (IEC) on all matters of electrotechnical standardization.

International Standards are drafted in accordance with the rules given in the ISO/IEC Directives, Part 2.

The main task of technical committees is to prepare International Standards. Draft International Standards adopted by the technical committees are circulated to the member bodies for voting. Publication as an International Standard requires approval by at least 75 % of the member bodies casting a vote.

Attention is drawn to the possibility that some of the elements of this document may be the subject of patent rights. ISO shall not be held responsible for identifying any or all such patent rights.

ISO 1652 was prepared by Technical Committee ISO/TC 45, *Rubber and rubber products*, Subcommittee SC 3, *Raw materials (including latex) for use in the rubber industry*.

This fourth edition cancels and replaces the third edition (ISO 1652:2004), which has been technically revised. The main change is the inclusion of precision data (see Annex B).

Rubber latex — Determination of apparent viscosity by the Brookfield test method

WARNING — Persons using this International Standard should be familiar with normal laboratory practice. This standard does not purport to address all of the safety problems, if any, associated with its use. It is the responsibility of the user to establish appropriate safety and health practices and to ensure compliance with any national regulatory conditions.

1 Scope

This International Standard specifies a method for the determination of the apparent viscosity of both natural rubber latex concentrate and synthetic rubber latices by the Brookfield method. The method is also suitable for the determination of the viscosity of natural latices from sources other than *Hevea brasiliensis* and also for compounded latices. Other methods for the determination of viscosity are referred to in Annex A.

2 Normative references

The following referenced documents are indispensable for the application of this document. For dated references, only the edition cited applies. For undated references, the latest edition of the referenced document (including any amendments) applies.

ISO 123, *Rubber latex — Sampling*

ISO 124, *Latex, rubber — Determination of total solids content*

3 Terms and definitions

For the purposes of this document, the following terms and definitions apply.

3.1

test sample

quantity of latex suitable for testing, obtained by straining a laboratory sample

[ISO 123]

4 Principle

The viscosity of a latex sample is determined by means of a viscometer which measures the torque produced on a specific spindle driven by an electric motor to rotate at a constant rotational frequency and at a controlled rate of shear while immersed to a specified depth in the latex. The apparent viscosity is obtained by multiplying the torque reading by a coefficient which depends on the rotational frequency and size of the spindle. Measurements may be made on the undiluted latex or on the latex after dilution to a required total-solids content.

This International Standard relates primarily to the manually operated type of viscometer rather than the digital ones currently produced. Comparative reference is made to the latter where appropriate.

NOTE Other methods exist for the determination of the viscosity of latices and emulsions (see Annex A).

5 Apparatus

5.1 Viscometer, consisting of an electric motor which drives, at a constant rotational frequency, a shaft to which spindles of different shapes and dimensions may be attached. The rotational frequency can be selected from a number of speeds. For the purpose of this International Standard, two are specified but other speeds may be used for practical reasons. The spindle is immersed in the latex to a specified depth and the drag on the spindle rotating in the latex causes a torque to be developed on the spindle shaft. The equilibrium torque developed is indicated by means of a pointer and a scale which is calibrated in units from 0 to 100¹).

The L instrument uses a spring torque of $67,37 \mu\text{N}\cdot\text{m} \pm 0,07 \mu\text{N}\cdot\text{m}$ ($673,7 \text{ dyn}\cdot\text{cm} \pm 0,7 \text{ dyn}\cdot\text{cm}$) at full-scale deflection.

The R instrument uses a spring torque of $718,7 \mu\text{N}\cdot\text{m} \pm 0,7 \mu\text{N}\cdot\text{m}$ ($7\,187 \text{ dyn}\cdot\text{cm} \pm 7 \text{ dyn}\cdot\text{cm}$) at full-scale deflection.

The spindles shall be accurately made in accordance with Figure 1 and the dimensions given in Table 1. They shall have a groove, or other marking device, on the shaft to indicate the required depth of immersion.

A spirit level shall be incorporated in the motor housing to indicate, with the spindle attached to the motor shaft, when the spindle is vertical.

A guard shall be used to protect the spindle in operation. This shall consist of a rectangular bar of cross-section approximately $9,5 \text{ mm} \times 3 \text{ mm}$, with the corners rounded, bent into a U.

The upper ends of the guard shall be attached to the motor housing in such a way that the guard is removable for cleaning. The horizontal portion of the guard shall join the vertical legs of the guard through internal radii of approximately 6 mm.

NOTE Although the function of the guard is primarily for protection, it is an integral part of the equipment and the measured viscosity is likely to change if it is not in place.

The perpendicular distance between the inner faces of the two vertical legs of the guard when the guard is securely attached to the motor housing shall be $31,8 \text{ mm} \pm 0,8 \text{ mm}$ with the L instrument and $76,2 \text{ mm} \pm 0,8 \text{ mm}$ with the R instrument. The perpendicular distance between the upper face of the horizontal portion of the guard and the bottom of the spindle shaft, when the guard is securely attached to the motor housing and when the spindle is attached to the motor shaft, shall be not less than 10 mm with the L instrument and not less than 4,5 mm with the R instrument.

5.2 Beaker, glass, of internal diameter at least 85 mm and capacity 600 cm³.

The actual value of the viscosity determined is affected by the size of the beaker. Care shall therefore be taken to ensure that the size of the container used is consistent.

5.3 Water-bath, capable of being maintained at $23 \text{ }^\circ\text{C} \pm 2 \text{ }^\circ\text{C}$, or $27 \text{ }^\circ\text{C} \pm 2 \text{ }^\circ\text{C}$ in tropical climates.

6 Sampling

Carry out sampling in accordance with one of the methods described in ISO 123. From the sample thus obtained, prepare a test sample as specified in ISO 123.

1) Suitable instruments are obtainable from several sources, such as Brookfield Engineering Laboratories, Inc., Stoughton, Mass. 02072, USA (whose models LVF and LVT meet the requirements for the L instrument and models RVF and RVT meet the requirements for the R instrument) and Gebrüder Haake GmbH, Dieselstr. 4, D-76227 Karlsruhe, Germany. This information is given for the convenience of users of this International Standard and does not constitute an endorsement by ISO of these products.

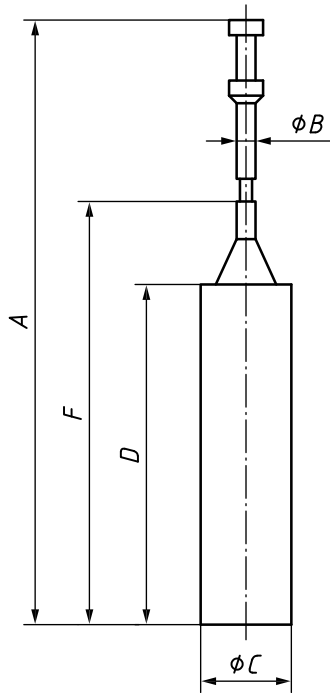

a) No. L1

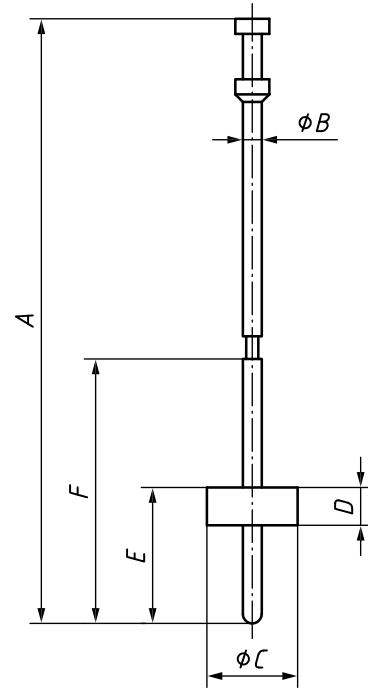

b) Nos. L2 and L3

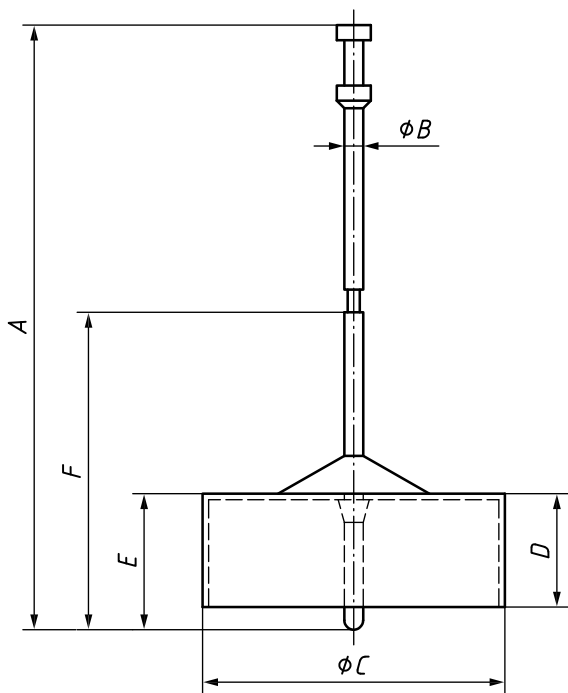

c) No. R1

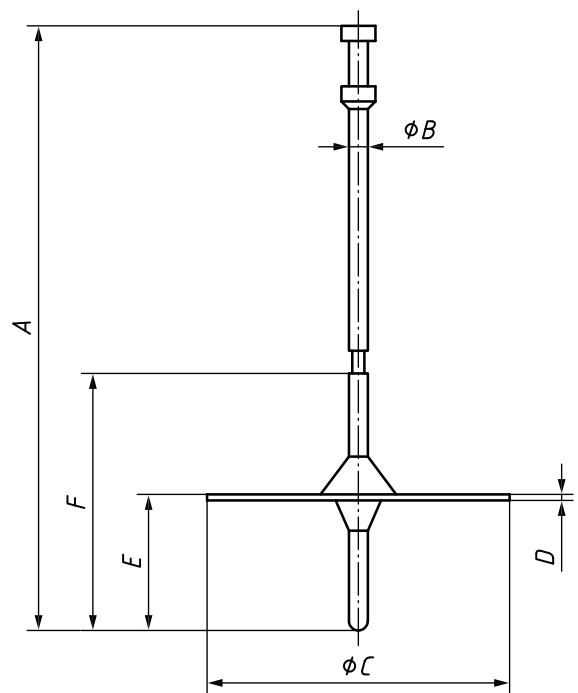

d) Nos. R2 and R3

Figure 1 — Spindles

Table 1 — Spindle dimensions

Values in millimetres

| Spindle number | A ±1,3 | B ±0,03 | C ±0,03 | D ±0,06 | E ±1,3 | F ±0,15 |
|----------------|--------------------------------------|------------|--------------------|--------------------|-----------|------------|
| L1 | 115,1 | 3,18 | 18,84 | 65,10 | — | 81,0 |
| L2 | 115,1 | 3,18 | 18,72 | 6,86 | 25,4 | 50,0 |
| L3 | 115,1 | 3,18 | 12,70 | 1,65 | 25,4 | 50,0 |
| R1 | 133,3 | 3,18 | 56,26 ^a | 22,48 ^b | 27,0 | 61,1 |
| R2 | 133,3 | 3,18 | 46,93 | 1,57 | 27,0 | 49,2 |
| R3 | 133,3 | 3,18 | 34,69 | 1,65 | 27,0 | 49,2 |
| ^a | Wall thickness approximately 0,6 mm. | | | | | |
| ^b | Wall thickness approximately 1,0 mm. | | | | | |

7 Further preparation of test sample

If the requirement is for the viscosity at a specific solids content, determine the total solids content of the test sample of latex in accordance with ISO 124 and then, if necessary, accurately adjust to the required value by the addition of distilled water or water of equivalent purity. Add the water slowly to the latex and stir the mixture gently for 5 min, taking care to avoid the inclusion of air.

If the test sample contains occluded air and has a viscosity of less than 200 mPa·s (200 cP), remove the air by allowing the latex to stand for 24 h.

If the latex contains occluded air and no other volatile component, and has a viscosity greater than about 200 mPa·s (200 cP), remove the air by allowing the latex to stand under vacuum until foaming ceases.

8 Procedure

Pour a portion of the test sample (see Clause 7) into the beaker (5.2). Place the beaker in the water-bath (5.3), maintained at 23 °C ± 2 °C or 27 °C ± 2 °C, and stir the latex gently until its temperature is 23 °C ± 2 °C or 27 °C ± 2 °C. Record the precise temperature. Immediately attach the spindle securely to the motor shaft and attach the guard securely to the motor housing of the viscometer (5.1). Carefully insert the spindle and guard into the latex, in such a way as to avoid air being trapped on the underside of the spindle, until the surface of the latex is at the midpoint of the groove on the spindle shaft. The spindle shall be positioned vertically in the sample (as indicated by the spirit level on the motor housing) and in the centre of the beaker.

Select the rotational frequency of the instrument as follows:

L instrument: 60 min⁻¹ ± 0,2 min⁻¹ (1 s⁻¹ ± 0,003 s⁻¹)

R instrument: 20 min⁻¹ ± 0,2 min⁻¹ (0,333 s⁻¹ ± 0,003 s⁻¹)

Switch on the viscometer motor and take the equilibrium reading to the nearest unit scale division, in accordance with the manufacturer's operating instructions. Equilibrium may not be attained until 20 s to 30 s have elapsed.

It is preferable to have a reading between 10 and 90 scale units. If the reading is less than 10 scale units or greater than 90 scale units, then a further reading should be taken using the next larger or smaller spindle, respectively. This refinement is not practical with digital viscometers.

If the method is being used for monitoring or quality control purposes, care shall be taken to ensure that the spindle size and rotational frequency are constant.

For specific purposes, such as the assessment of rheological characteristics, it may be desirable to measure the viscosity at more than one rotational frequency (see Annex A). For this purpose, the viscometer shall be switched off and the latex allowed to stand for not less than 30 s before restarting at another speed. If the determination is made at more than one rotational frequency or at speeds other than those specified above, this fact shall be included in the test report.

9 Expression of results

Calculate the viscosity of the latex, expressed in millipascal seconds (centipoises), using the appropriate factor given in Table 2.

Table 2 — Factors necessary to convert readings on the scale 0 to 100 to millipascal seconds (centipoises)

| Spindle number | Factor |
|----------------|--------|
| L1 | ×1 |
| L2 or R1 | ×5 |
| L3 or R2 | ×20 |
| R3 | ×50 |

10 Precision

See Annex B.

11 Test report

The test report shall include the following particulars:

- a) a reference to this International Standard;
- b) all details necessary to identify the test sample;
- c) the results and the units in which they are expressed;
- d) the instrument used (L or R);
- e) the spindle number and rotational speed used;
- f) the total solids content of the latex and whether the latex was diluted;
- g) the test temperature of the latex;
- h) any unusual features noted during the determination;
- i) any operation not included in this International Standard or in the International Standards to which reference is made, as well as any operation regarded as optional;
- j) the date of the test.

Annex A (informative)

Viscosity-measurement methods

Latices are generally non-Newtonian in their behaviour, i.e. their resistance to shear is not directly related to the rate at which the shear is applied. It is for this reason that the viscosity measured is referred to as an “apparent” viscosity.

The ratio of the apparent viscosities measured using the same spindle at two different rotational frequencies can provide an indication of the degree of thixotropy (thixotropy index) and is particularly useful in comparing the effects of different thickening agents in a latex or latex compound.

There are numerous other methods which exist for the determination of the apparent viscosity of emulsions, for example:

ISO 2555, *Plastics — Resins in the liquid state or as emulsions or dispersions — Determination of apparent viscosity by the Brookfield Test method* (which uses similar equipment with different spindles);

ISO 3219, *Plastics — Polymers/resins in the liquid state or as emulsions or dispersions — Determination of viscosity using a rotational viscometer with defined shear rate.*

There are also methods which employ efflux viscometers. Their use is generally not appropriate for latices. However, because of their simplicity they are convenient for monitoring compounds being used in manufacturing.

Annex B (informative)

Precision statement

B.1 General

The precision of the test method was determined in accordance with ISO/TR 9272. Refer to this document for terminology and other statistical details.

The precision data are given in Table B.1. The precision parameters should not be used for acceptance or rejection of any group of materials without documentation that the parameters are applicable to those particular materials and specific test protocols of the test method. The precision is expressed on the basis of a 95 % confidence level for the values established for repeatability, r , and reproducibility, R .

The results contained in Table B.1 are average values and give an estimate of the precision of this test method as determined in an interlaboratory testing programme (ITP) carried out in 2007. 12 laboratories took part in this ITP, performing duplicate analyses on two samples, A and B, which were prepared from high-ammonia latex. Before the bulk was sub-sampled into two bottles labelled A and B, it was filtered and homogenized by thorough stirring. Thus, essentially, samples A and B were the same and were treated as such in the statistical computations. Each participating laboratory was required to carry out the test using these two samples on the dates given to them.

A Type 1 precision was determined, based on the method of sampling used for the interlaboratory test programme.

The precision data were obtained using digital viscometers since the analogue scale is unsuitable for measuring the differences in viscosity.

Table B.1 — Precision data

| Average result | Within-laboratory | | Between laboratories | |
|---|-------------------|------|----------------------|------|
| | s_r | r | s_R | R |
| 60,08 | 0,05 | 0,15 | 0,09 | 0,25 |
| s_r is the within-laboratory standard deviation (in measurement units); r is the repeatability (in measurement units); s_R is the between-laboratory standard deviation (in measurement units); R is the reproducibility (in measurement units). | | | | |

B.2 Repeatability

The repeatability, r , in measurement units, of the test method has been established as the appropriate value tabulated in Table B.1. Two single test results, obtained from the same laboratory using the normal test procedure, that differ by more than the tabulated r (for any given level) should be considered to have come from different, or non-identical, sample populations.

B.3 Reproducibility

The reproducibility, R , in measurement units, of the test method has been established as the appropriate value tabulated in Table B.1. Two single test results, obtained from different laboratories using the normal test procedure, that differ by more than the tabulated R (for any given level) should be considered to have come from different, or non-identical, sample populations.

B.4 Bias

In test method terminology, bias is the difference between an average test value and the reference (or true) test property value. Reference values do not exist for this test method since the value of the test property is exclusively defined by the test method. Bias cannot therefore be determined for this particular method.

.....

Bibliography

- [1] ISO 2555, *Plastics — Resins in the liquid state or as emulsions or dispersions — Determination of apparent viscosity by the Brookfield Test method*
- [2] ISO 3219, *Plastics — Polymers/resins in the liquid state or as emulsions or dispersions — Determination of viscosity using a rotational viscometer with defined shear rate*
- [3] ISO/TR 9272, *Rubber and rubber products — Determination of precision for test method standards*

ICS 83.040.10

Price based on 9 pages