

INTERNATIONAL
STANDARD

ISO
1520

Third edition
2006-11-15

Paints and varnishes — Cupping test

Peintures et vernis — Essai d'emboutissage



Reference number
ISO 1520:2006(E)

© ISO 2006

PDF disclaimer

This PDF file may contain embedded typefaces. In accordance with Adobe's licensing policy, this file may be printed or viewed but shall not be edited unless the typefaces which are embedded are licensed to and installed on the computer performing the editing. In downloading this file, parties accept therein the responsibility of not infringing Adobe's licensing policy. The ISO Central Secretariat accepts no liability in this area.

Adobe is a trademark of Adobe Systems Incorporated.

Details of the software products used to create this PDF file can be found in the General Info relative to the file; the PDF-creation parameters were optimized for printing. Every care has been taken to ensure that the file is suitable for use by ISO member bodies. In the unlikely event that a problem relating to it is found, please inform the Central Secretariat at the address given below.

© ISO 2006

All rights reserved. Unless otherwise specified, no part of this publication may be reproduced or utilized in any form or by any means, electronic or mechanical, including photocopying and microfilm, without permission in writing from either ISO at the address below or ISO's member body in the country of the requester.

ISO copyright office
Case postale 56 • CH-1211 Geneva 20
Tel. + 41 22 749 01 11
Fax + 41 22 749 09 47
E-mail copyright@iso.org
Web www.iso.org

Published in Switzerland

Contents		Page
1	Scope	1
2	Normative references	1
3	Principle	1
4	Apparatus	1
5	Sampling	3
6	Test panels	3
7	Procedure	3
8	Supplementary test conditions	4
9	Expression of results	4
10	Precision	5
11	Test report	5
	Bibliography	6

Foreword

ISO (the International Organization for Standardization) is a worldwide federation of national standards bodies (ISO member bodies). The work of preparing International Standards is normally carried out through ISO technical committees. Each member body interested in a subject for which a technical committee has been established has the right to be represented on that committee. International organizations, governmental and non-governmental, in liaison with ISO, also take part in the work. ISO collaborates closely with the International Electrotechnical Commission (IEC) on all matters of electrotechnical standardization.

International Standards are drafted in accordance with the rules given in the ISO/IEC Directives, Part 2.

The main task of technical committees is to prepare International Standards. Draft International Standards adopted by the technical committees are circulated to the member bodies for voting. Publication as an International Standard requires approval by at least 75 % of the member bodies casting a vote.

Attention is drawn to the possibility that some of the elements of this document may be the subject of patent rights. ISO shall not be held responsible for identifying any or all such patent rights.

ISO 1520 was prepared by Technical Committee ISO/TC 35, *Paints and varnishes*, Subcommittee SC 9, *General test methods for paints and varnishes*.

This third edition cancels and replaces the second edition (ISO 1520:1999), which has been technically revised. The main changes are:

- the determination is carried out in duplicate instead of triplicate;
- precision data have been added;
- the text has been editorially revised and the normative references have been reviewed.

Introduction

This International Standard is one of six standards which specify empirical test procedures for assessing the resistance of coatings of paints, varnishes and related products to cracking and/or detachment from the substrate under different conditions of deformation.

The other standards are:

ISO 1519, *Paints and varnishes — Bend test (cylindrical mandrel)*

ISO 6272-1, *Paints and varnishes — Rapid-deformation (impact resistance) tests — Part 1: Falling-weight test, large-area indenter*

ISO 6272-2, *Paints and varnishes — Rapid-deformation (impact resistance) tests — Part 2: Falling-weight test, small-area indenter*

ISO 6860, *Paints and varnishes — Bend test (conical mandrel)*

ISO 17132, *Paints and varnishes — T-bend test*

The method to be chosen depends on the property which has to be measured. In principle, all these tests differ technically from each other and differ in accuracy.

Paints and varnishes — Cupping test

1 Scope

This International Standard specifies an empirical method for assessing the resistance of a coating of paint, varnish or related product to cracking and/or detachment from a metal substrate when subjected to gradual deformation by indentation under standard conditions (see 7.1).

For a multi-coat system, each coat may be tested separately or the complete system may be tested.

The method may be carried out as follows:

- either as a “pass/fail” test, by testing to a specified depth of indentation to assess compliance with a particular requirement;
- or by gradually increasing the depth of indentation to determine the minimum depth at which the coating cracks and/or becomes detached from the substrate.

2 Normative references

The following referenced documents are indispensable for the application of this document. For dated references, only the edition cited applies. For undated references, the latest edition of the referenced document (including any amendments) applies.

ISO 1513, *Paints and varnishes — Examination and preparation of samples for testing*

ISO 1514, *Paints and varnishes — Standard panels for testing*

ISO 2808, *Paints and varnishes — Determination of film thickness*

ISO 15528, *Paints, varnishes and raw materials for paints and varnishes — Sampling*

3 Principle

The product or system under test is applied at uniform thickness to flat panels of uniform surface texture.

After drying/curing, the elastic properties of the paint film are determined by first placing the coated panel between two rings, namely the retaining ring and the drawing die. The panel is then pushed by a hemispherical indenter at a steady rate into the die so as to form a dome shape with the coating on the outside.

The deformation is increased either to a depth agreed between the interested parties or until the coating cracks and/or detaches from the substrate, and the result is then assessed.

4 Apparatus

4.1 Cupping test apparatus, which conforms to the design and dimensions shown in Figure 1 and consists essentially of the following components:

4.1.1 Drawing die, made of surface-hardened steel and of which the surface in contact with the test panel is plane-polished.

4.1.2 Retaining ring, of which the surface in contact with the test panel is plane-polished and parallel to the contacting surface of the die.

4.1.3 Indenter, of which the part contacting the test panel is of hardened polished steel and forms a hemisphere of 20 mm diameter.

It is preferable to use a mechanically driven indenter, but a hand-operated apparatus can also be used, provided the standard conditions of test (see Clause 7) can be achieved.

During the test, the indenter shall be prevented from turning and the centre of the spherical portion shall not deviate from the axis of the die by more than 0,1 mm. The indenter shall move at a steady speed of between 0,1 mm/s and 0,3 mm/s during the test.

The tip of the hemisphere, when at the zero position, shall be in the same plane as the face of the retaining ring, in contact with the test panel and in the centre of the bore of the drawing die.

4.1.4 Measuring device(s), which can measure the depth of the indentation made by the indenter to the nearest 0,1 mm and the thickness of the test panel to the nearest 0,01 mm.

4.2 Microscope or magnifier, preferably with a magnification range extending up to $\times 10$, if necessary to view the panels during or after deformation.

Dimensions in millimetres

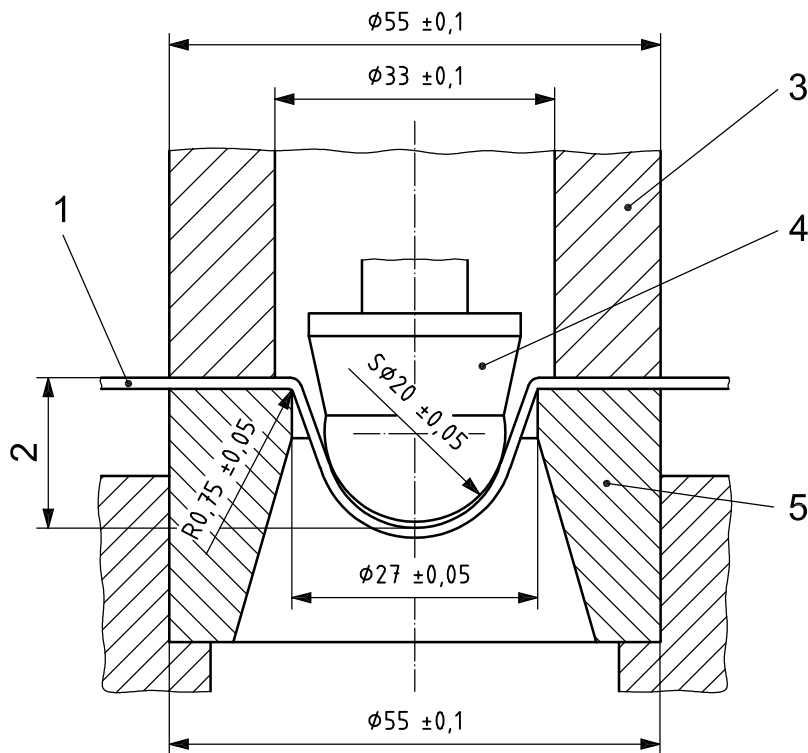

- Key**
- 1 test panel
 - 2 depth of indentation
 - 3 retaining ring
 - 4 indenter and ball
 - 5 die

Figure 1 — Cupping test apparatus

5 Sampling

Take a representative sample of the product to be tested (or of each product in the case of a multi-coat system) in accordance with ISO 15528.

Examine and prepare each sample for testing in accordance with ISO 1513.

6 Test panels

6.1 Substrate

Unless otherwise specified, select the substrate from one of those described in ISO 1514 and in accordance with the intended use.

The test panels shall be flat and free from distortion and capable of withstanding the cupping test without cracking.

NOTE If cracking of the substrate occurs before the cracking and/or detachment of the paint film, the test result of the paint film can be reported to be better than the indentation depth at which cracking of the substrate occurred.

6.2 Dimensions

The test panels shall be rectangular with the following dimensions:

- Thickness: not less than 0,3 mm and not more than 1,25 mm, as specified, measured with e.g. a micrometer (see 4.1.4) to the nearest 0,01 mm.
- Width and length: two tests shall be carried out, either on a single long strip or on two separate panels. The indentation centres in these tests shall be at least 35 mm from any edge, and the distance between any two indentation centres shall be a minimum of 70 mm. The test panels may be cut to size after coating and drying, provided no distortion occurs.

6.3 Preparation and coating

Unless otherwise agreed, prepare each test panel in accordance with ISO 1514 and then coat it by the specified method with the product or system under test.

6.4 Drying and conditioning

Dry (or stove) and age (if applicable) each coated test panel for the specified time and under the specified conditions. Unless otherwise agreed, condition the coated panels at $(23 \pm 2)^\circ\text{C}$ and a relative humidity of $(50 \pm 5)\%$ for a minimum period of 16 h before testing.

6.5 Thickness of coating

Determine the thickness, in micrometres, of the dried coating by one of the procedures specified in ISO 2808.

7 Procedure

7.1 Test conditions

Unless otherwise specified, carry out the test in duplicate at $(23 \pm 2)^\circ\text{C}$ and a relative humidity of $(50 \pm 5)\%$ (see also ISO 3270).

7.2 Procedure for a single specified depth of indentation

7.2.1 Carry out the following procedure in duplicate (if the results differ, additional tests shall be made).

7.2.2 Hold the test panel firmly without excessive pressure between the retaining ring (4.1.2) and the drawing die (4.1.1) with the coating towards the die and with the hemispherical end of the indenter (4.1.3) just in contact with the uncoated side of the test panel (zero position of the indenter). Adjust the panel until the central axis of the indenter intersects the panel at least 35 mm from the edge.

7.2.3 Advance the hemispherical end of the indenter into the test piece at a steady rate between 0,1 mm/s and 0,3 mm/s until the specified depth is reached, i.e. until the indenter has travelled this distance from the zero position.

7.2.4 Using normal corrected vision or, if necessary, a microscope or magnifier of $\times 10$ magnification (4.2), examine the coating of the test panel for cracking and/or detachment from the substrate.

If a microscope or magnifier is used, it is essential to mention this fact in the test report to avoid misleading comparisons with results obtained using normal vision only.

7.3 Procedure for determination of minimum depth of indentation to cause failure

Unless otherwise specified, test the test panels in accordance with the procedure given in 7.2 using normal corrected vision, or, if necessary, a microscope or magnifier of $\times 10$ magnification, until a crack is first observed on the surface of the coating and/or the coating begins to become detached from the substrate.

Stop the indenter at this point and measure the depth of indentation (see Figure 1) to the nearest 0,1 mm, i.e. the distance travelled by the indenter from the zero position. Confirm the result by repeating the determination on a fresh panel (if the result differs, further determinations shall be made).

8 Supplementary test conditions

To enable the method to be carried out, the following supplementary information needs to be specified in addition to that in the preceding clauses:

- a) the material, dimensions and surface preparation of the substrate;
- b) the method of application of the test coating to the substrate;
- c) the duration and conditions of drying (or stoving) and ageing (if applicable) of the coated panels before testing;
- d) the thickness, in micrometres, of the dry coating, together with the method of measurement used, and whether it is a single coating or a multi-coat system;
- e) the temperature and humidity during the test.

9 Expression of results

The test results shall be reported in one of the following ways:

- either whether or not the coating on the test panels passed when tested at the specified indentation depth;
- or the maximum depth of indentation at which the coating passed, expressed as the mean of two valid results (duplicates) to the nearest 0,1 mm.

10 Precision

10.1 Repeatability limit r

The repeatability limit r is the value below which the absolute difference between two single test results, each the mean of duplicates, can be expected to lie when this method is used under repeatability conditions (i.e. the test results are obtained on identical material by one operator in one laboratory within a short interval of time using the standardized test method). For this method, r is ± 1 mm, with a 95 % probability.

10.2 Reproducibility limit R

The reproducibility limit R is the value below which the absolute difference between two test results, each the mean of duplicates, can be expected to lie when this test method is used under reproducibility conditions (i.e. the test results are obtained on identical material by operators in different laboratories using the standardized test method). For this method, R is ± 2 mm, with a 95 % probability.

11 Test report

The test report shall include the following information:

- a) all information necessary for complete identification of the product tested (manufacturer, trade name, batch number, etc.);
- b) a reference to this International Standard (ISO 1520:2006);
- c) the items of supplementary information referred to in Clause 8;
- d) the source of the supplementary information referred to in Clause 8;
- e) the results of the test, expressed in accordance with Clause 9;
- f) whether the defects were assessed using normal corrected vision or a microscope or magnifier and, if this was used, the magnification setting at which it was used;
- g) whether a hand-operated or a mechanically driven apparatus was used;
- h) any deviations from the test method specified;
- i) any unusual features (anomalies) observed during the test;
- j) the date of the test.

Bibliography

- [1] ISO 3270, *Paints and varnishes and their raw materials — Temperatures and humidities for conditioning and testing*

