

INTERNATIONAL
STANDARD

ISO
1496-4

First edition
1991-12-15

Series 1 freight containers — Specification and testing —

Part 4:

Non-pressurized containers for dry bulk

Conteneurs de la série 1 — Spécifications et essais —

Partie 4: Conteneurs non pressurisés pour produits solides en vrac



Reference number
ISO 1496-4:1991(E)

Contents

	Page
1 Scope	1
2 Normative references	1
3 Definitions	2
4 Dimensions and ratings	2
4.1 External dimensions	2
4.2 Internal dimensions	2
4.3 Ratings	2
5 Design requirements	2
5.1 General	2
5.2 Corner fittings	3
5.3 Base structure	3
5.4 End structure	4
5.5 Side structure	4
5.6 Walls (box type only)	4
5.7 Shell (hopper type only)	4
5.8 Openings	4
5.9 Construction	5
5.10 Requirements — Optional features	5
6 Testing	6
6.1 General	6
6.2 Test No. 1 — Stacking	6
6.3 Test No. 2 — Lifting from the four top corner fittings	7
6.4 Test No. 3 — Lifting from the four bottom corner fittings	8
6.5 Test No. 4 — External restraint (longitudinal)	8
6.6 Test No. 5 — Strength of end walls (box type only)	8

© ISO 1991

All rights reserved. No part of this publication may be reproduced or utilized in any form or by any means, electronic or mechanical, including photocopying and microfilm, without permission in writing from the publisher.

International Organization for Standardization
Case Postale 56 • CH-1211 Genève 20 • Switzerland

Printed in Switzerland

6.7	Test No. 6 — Strength of side walls (box type only)	9
6.8	Test No. 7 — Strength of the roof (where provided)	9
6.9	Test No. 8 — Floor strength (box type only)	9
6.10	Test No. 9 — Rigidity (transverse)	9
6.11	Test No. 10 — Rigidity (longitudinal)	10
6.12	Test No. 11 — Lifting from fork-lift pockets (where provided)	10
6.13	Test No. 12 — Lifting from the base at grapples-arm positions (where provided)	11
6.14	Test No. 13 — Weatherproofness	11
6.15	Test No. 14 — Internal longitudinal restraint (hopper type only)	11
6.16	Test No. 15 — Internal lateral restraint (hopper type only)	12
6.17	Test No. 16 — Walkways (where provided)	12
6.18	Test No. 17 — Ladders (where provided)	12
6.19	Test No. 18 — Airtightness test (type codes 23 and 83)	13

Annexes

A	Diagrammatic representation of capabilities appropriate to all types and sizes of dry bulk non-pressurized containers, except where otherwise stated	14
B	Details of requirements for load-transfer areas in base structures of containers	20
C	Dimensions of fork-lift pockets (where provided)	26
D	Dimensions of grapples-arm lifting areas (where provided)	27
E	Dimensions of gooseneck tunnels (where provided)	29
F	Typical examples of the location of openings for loading of dry bulk non-pressurized box-type containers	30
G	Bibliography	31

Foreword

ISO (the International Organization for Standardization) is a worldwide federation of national standards bodies (ISO member bodies). The work of preparing International Standards is normally carried out through ISO technical committees. Each member body interested in a subject for which a technical committee has been established has the right to be represented on that committee. International organizations, governmental and non-governmental, in liaison with ISO, also take part in the work. ISO collaborates closely with the International Electrotechnical Commission (IEC) on all matters of electrotechnical standardization.

Draft International Standards adopted by the technical committees are circulated to the member bodies for voting. Publication as an International Standard requires approval by at least 75 % of the member bodies casting a vote.

International Standard ISO 1496-4 was prepared by Technical Committee ISO/TC 104, *Freight containers*, Sub-Committee SC 2, *Specific purpose containers*.

ISO 1496 consists of the following parts, under the general title *Series 1 freight containers — Specification and testing*:

- *Part 1: General cargo containers for general purposes*
- *Part 2: Thermal containers*
- *Part 3: Tank containers for liquids, gases and pressurized dry bulk*
- *Part 4: Non-pressurized containers for dry bulk*
- *Part 5: Platform and platform-based containers*
- *Part 6: International cargo-security devices*

Annexes A, B, C, D and E form an integral part of this part of ISO 1496. Annexes F and G are for information only.

Introduction

The following grouping of container types is used for specification purposes in ISO 1496:

Part 1		
General purpose		00 to 09
Specific purpose		
closed, vented/ventilated		10 to 19
open top		50 to 59
Part 2		
Thermal		30 to 49
Part 3		
Tank		70 to 79
Dry bulk, pressurized		85 to 89
Part 4		
Bulk, non-pressurized (box type)		20 to 24
Bulk, non-pressurized (hopper type)		80 to 84
Part 5		
Platform (container)		60
Platform-based with incomplete superstructure and fixed ends		61 and 62
Platform-based with incomplete superstructure and folding ends		63 and 64
Platform-based with complete superstructure		65 to 69

NOTE 1 Containers types 90 to 99 are reserved for air/surface containers (see ISO 8323).

This page intentionally left blank

Series 1 freight containers — Specification and testing —

Part 4:

Non-pressurized containers for dry bulk

1 Scope

1.1 This part of ISO 1496 specifies the basic specifications and testing requirements for ISO series 1 freight containers of the dry bulk container non-pressurized type which are suitable for international exchange and for conveyance by road, rail and sea, including interchange between these forms of transport.

1.2 As the density and flow characteristics of dry bulk cargoes vary widely, containers complying with this part of ISO 1496 are not expected to be suitable for the carriage of all such cargoes. Therefore, except where otherwise stated, the requirements of this International Standard are minimum requirements.

Containers to be used for the carriage of dangerous goods may be subject to additional international and national requirements as applied by competent authorities.

1.3 The container types covered by this part of ISO 1496 are given in table 1.

1.4 The marking requirements for these containers shall be in accordance with the principles embodied in ISO 6346.

NOTE 2 Some types of freight containers constructed in accordance with ISO 1496-1 may satisfactorily be used for the transport of certain non-packed dry bulk solids. Where such containers are used for this purpose, it is essential that care be taken to ensure that the design loadings are not exceeded under operating conditions.

Table 1 — Container types

Type	Type code designation ¹⁾	
	Box types	Hopper types
Dry bulk non-pressurized,		
closed	20	80
vented	21	81
ventilated	22	82
airtight	23	83
[spare]	24	84
1) In accordance with ISO 6346.		

2 Normative references

The following standards contain provisions which, through reference in this text, constitute provisions of this part of ISO 1496. At the time of publication, the editions indicated were valid. All standards are subject to revision, and parties to agreements based on this part of ISO 1496 are encouraged to investigate the possibility of applying the most recent editions of the standards indicated below. Members of IEC and ISO maintain registers of currently valid International Standards.

ISO 668:1988, *Series 1 freight containers — Classification, dimensions and ratings*.

ISO 830:1981, *Freight containers — Terminology*, and its amendments: ISO 830:1981/Amd.1:1984 and ISO 830:1981/Amd.2:1988.

ISO 1161:1984, *Series 1 freight containers — Corner fittings — Specification*.

ISO 6346:1984, *Freight containers — Coding, identification and marking*, and its amendment: ISO 6346:1984/Amd.1:1988.

3 Definitions

For the purposes of this part of ISO 1496, the definitions given in ISO 830, together with the following, apply. However, for practical reasons, certain definitions taken and adapted from ISO 830 are given below.

3.1 non-pressurized dry bulk container: Container for the transport of dry bulk solids, capable of withstanding the loads resulting from filling, transport motions and discharging of non-packaged dry bulk solids, having filling and discharge apertures and fittings and complying with the requirements of this part of ISO 1496.

3.1.1 box type: Dry bulk non-pressurized container for tipping discharge having a parallelepiped cargo space and a door opening at least at one end, which therefore may also be used as a general-purpose freight container.

3.1.2 hopper type: Dry bulk non-pressurized container for horizontal discharge having no door opening, which therefore may not be used as a general-purpose freight container.

NOTE 3 For the sake of simplicity, dry bulk containers will be referred to as containers in this part of ISO 1496.

3.2 dry bulk solids: Assemblies of separate solid particles normally substantially in contact with one another which are, or which may be rendered, capable of fluid flow.

3.3 openings for cargo loading: Openings provided in a container for the filling of dry bulk solids.

3.4 openings for cargo discharging: Openings provided in a container for the discharge of dry bulk solids.

3.5 interface for external fumigation device: Point(s) at which the connection between the container and any external fumigation device is connected or disconnected.

3.6 dangerous goods: Those substances classified as dangerous by the United Nations committee of experts on the transport of dangerous goods or by the competent authority as defined in 3.7.

3.7 competent authority: The authority or authorities designated as such in each country or in

each specified case by the governments concerned, for the approval of dry bulk containers.

3.8 bulk density: The mass per unit volume of a dry bulk solid measured when the dry bulk solid is in a loose or non-compacted condition.

3.9 cargo space: The space bounded by the container walls or shell when all apertures are closed.

4 Dimensions and ratings

4.1 External dimensions

The overall external dimensions and tolerances of the freight containers covered by this part of ISO 1496 shall be those established in ISO 668, except that containers may be of reduced height, in which case they shall be designated 1AX, 1BX, 1CX and 1DX. No part of the container, its associated fittings and/or equipment shall project beyond these specified overall external dimensions.

4.2 Internal dimensions

Internal dimensions of containers shall be as large as possible but, in any case, 1AA, 1A, 1BB, 1B, 1CC, 1C and 1D box type containers (type code 20 to 24) shall have a minimum internal width of 2 330 mm¹⁾. This dimension applies when measured at a temperature of 20 °C (68 °F). Measurements taken at other temperatures shall be adjusted accordingly.

4.3 Ratings

The values of the rating *R*, the maximum gross mass of the container, shall be those specified in ISO 668. However, taking account of the high density of many fluid cargoes, the values of the rating *R* chosen for the design and testing of 1BB, 1B, 1CC and 1C tank containers may be higher than those specified in ISO 668. For all containers in operation, such values shall in no case exceed the rating allowed for 1AA and 1A containers in ISO 668.

5 Design requirements

5.1 General

All containers shall be capable of fulfilling the following requirements.

5.1.1 The strength requirements for containers are given in diagrammatic form in annex A (these requirements are applicable to all containers as complete units except where otherwise stated).

1) 2 330 mm = 91 3/4 in

5.1.2 The strength requirements for corner fittings (see also 5.2) are specified in ISO 1161.

5.1.3 The container shall be capable of withstanding the loads and test forces specified in clause 6.

5.1.4 As the effects of loads encountered under any dynamic operating condition should only approach, but not exceed, the effects of the corresponding test loads, it is implicit that the capabilities of containers indicated in annex A and demonstrated by the tests described in clause 6 shall not be exceeded in any mode of operation.

5.1.5 Any closure in a container which, if unsecured, could lead to a hazardous situation, shall be provided with an adequate securing system having, so far as may be practicable, external indication of the positive securement of that closure in the appropriate operating position.

In particular, doors and closures for cargo loading and cargo-discharging openings shall be capable of being securely fastened in the open or closed position.

5.1.6 Any removable roof or roof section shall be fitted with locking devices such that an observer at ground level can check (when the container is on a rail or highway carrying vehicle) that the roof is secured.

5.1.7 All containers shall be weatherproof as required by test No. 13 (see 6.14).

5.2 Corner fittings

5.2.1 General

All containers shall be equipped with top and bottom corner fittings. The requirements and positioning of the corner fittings are given in ISO 1161. The upper faces of the top corner fittings shall protrude above the top of the container by a minimum of 6 mm²⁾ (see 5.3.4). By "top of the container" is understood the highest level of the top part of the container, for example the level of the top of the closure of a cargo-loading opening.

5.2.2 Reinforcing zones or doubler plates

Whenever reinforced zones or doubler plates are provided to afford protection to the roof in the vicinity of the top corner fittings, such plates and their securements shall not protrude above the upper faces of the top corner fittings. These plates shall not extend more than 750 mm²⁾ from either end of the container but may extend the full width.

5.3 Base structure

5.3.1 All containers shall be capable of being supported by their bottom corner fittings only.

5.3.2 All containers, other than 1D and 1DX, shall be capable of being supported only by load-transfer areas in their base structure.

5.3.2.1 Consequently, these containers shall have end transverse members and sufficient intermediate load-transfer areas (or a flat underside) of sufficient strength to permit vertical load-transfer to or from the longitudinal member of a carrying vehicle. Such longitudinal members are assumed to lie within the two 250 mm²⁾ wide zones defined by the broken lines in figure B.1.

5.3.2.2 The lower faces of the load-transfer areas in the container base structure, including those of the end transverse members, shall be in one plane located

$$12,5 \text{ mm } \begin{matrix} +5 \\ -1,5 \end{matrix} \text{ mm}^{2)}$$

above the plane of the lower faces of the bottom corner fittings of the container (base plane).

Apart from the bottom corner fittings and bottom side rail, no part of the container shall project below this plane. However, doubler plates may be provided in the vicinity of the bottom corner fittings to afford protection to the understructure.

Such plates shall not extend more than 550 mm²⁾ from the outer end and 470 mm²⁾ from the side faces of the bottom corner fittings, and their lower faces shall be at least 5 mm²⁾ above the base plane of the container.

5.3.2.3 The transfer of load between the underside of the bottom side rails and carrying vehicles is not envisaged.

The transfer of load between side rails and handling equipment should only occur when provisions have been made in accordance with 5.10.1 and 5.10.2.

5.3.2.4 Containers having all their intermediate transverse members spaced 1000 mm²⁾ apart or less (or having a flat underside) shall be deemed to comply with the requirements of 5.3.2.1.

5.3.2.5 Requirements for containers not having transverse members spaced 1000 mm²⁾ apart or less (and not having a flat underside) are given in annex B.

2) 5 mm = 3/16 in; 6 mm = 1/4 in; 12,5 mm $\begin{matrix} +5 \\ -1,5 \end{matrix}$ mm = 1/2 in $\begin{matrix} +3/16 \\ -1/16 \end{matrix}$ in; 250 mm = 10 in; 470 mm = 18 1/2 in; 550 mm = 22 in; 750 mm = 29 1/2 in; 1 000 mm = 39 3/8 in

5.3.3 For 1D and 1DX containers, the level of the underside of the base structure is not specified, except insofar as it is implied in 5.3.4.

5.3.4 For all containers under dynamic conditions, or the static equivalent thereof, with the container having a load uniformly distributed over the floor in such a way that the combined mass of the container and test load is equal to $1,8R$, and when the container is supported at the corner fittings, no part of the base of the container shall deflect more than 6 mm^3 below the plane of the lower faces of the bottom corner fittings of the container (base plane).

5.4 End structure

For all containers other than 1D and 1DX, the sideways deflection of the top of the container with respect to the bottom of the container, at the time it is under full transverse rigidity test conditions, shall not cause the sum of the changes in length of the two diagonals to exceed 60 mm^3 .

5.5 Side structure

For all containers other than 1D and 1DX, the longitudinal deflection of the top of the container with respect to the bottom of the container at the time it is under full longitudinal rigidity test conditions shall not exceed 25 mm^3 .

5.6 Walls (box type only)

5.6.1 For all containers under full side wall test conditions, the deflection of the side walls, in relation to the plane formed by the external faces of the four corner fittings of each side, shall be as small as practicable and shall not exceed 40 mm^3 .

5.6.2 Where openings are provided in end or side walls, the ability of these walls to withstand test No. 5 and No. 6 (see 6.6 and 6.7) shall not be impaired.

5.7 Shell (hopper type only)

5.7.1 The shell of hopper-type containers shall be designed to withstand the effects of inertia of its content resulting from transport motion. For design purposes, these effects may be taken to be equivalent to a loading of $2R_g$ longitudinally, R_g laterally and $2R_g$ vertically⁴.

These loadings may be considered individually to be evenly distributed and to act through the geo-

metric centre of the shell. Vertical loadings are total loadings including dynamic effects.

5.7.2 The shell of hopper-type containers shall be capable of withstanding the requirements of 5.7.1 and the static head produced by upending the container while loaded to its rating R . Due regard shall be given to the dry bulk of highest density that is to be carried and to any compartmentation of the shell.

Under the full test conditions for internal lateral restraint, the deflection of any part of the container in relation to the plane formed by the external faces of the four corner fittings of each side shall be as small as practicable and shall not exceed 50 mm^3 .

5.8 Openings

5.8.1 General

All openings shall be so designed that, when closed, they prevent leakage of cargo.

5.8.2 Door opening(s) (box type only)

Box-type containers shall be provided with a door opening at least at one end, to enable them to be used as general-purpose freight containers.

Box-type containers designated 1A, 1B, 1C and 1D shall have a door opening preferably having dimensions equal to those of the internal cross-section of the containers and, in any case, not less than $2\,134 \text{ mm}^3$ high and $2\,286 \text{ mm}^3$ wide.

Box-type containers designated 1AA, 1BB and 1CC shall have a door opening preferably having dimensions equal to those of the internal cross-section of the containers and, in any case, not less than $2\,261 \text{ mm}^3$ high and $2\,286 \text{ mm}^3$ wide.

5.8.3 Opening(s) for loading

All containers shall be provided with one or more openings for loading. Their design, number and location shall be such as to

- permit proper distribution of the dry bulk solids which are loaded into the container by natural gravity or any other means which do not produce any internal pressure within the cargo space;
- comply with the possible additional requirements of the competent authority.

NOTE 4 Typical examples of arrangements of openings for loading box-type containers 1AA, 1A, 1BB, 1B, 1CC and 1C are given in annex F.

3) $6 \text{ mm} = 1/4 \text{ in}$; $25 \text{ mm} = 1 \text{ in}$; $40 \text{ mm} = 1\ 9/16 \text{ in}$; $50 \text{ mm} = 2 \text{ in}$; $60 \text{ mm} = 2\ 3/8 \text{ in}$; $2\,134 \text{ mm} = 7 \text{ ft}$; $2\,261 \text{ mm} = 7 \text{ ft } 5 \text{ in}$; $2\,286 \text{ mm} = 7 \text{ ft } 6 \text{ in}$

4) See 6.1.1, note 5.

5.8.4 Opening(s) for discharging

All containers shall be provided with at least one opening for discharging, designed and located in such a way as to allow complete discharge by natural gravity or other means which do not produce any internal pressure/vacuum within the cargo space, or by any combination of such means.

The opening(s) for gravity discharging by tilting the container shall have an area sufficient to achieve total discharge.

5.8.5 Inspection and maintenance openings (hopper type only)

5.8.5.1 Hopper-type containers shall be provided with manholes or other openings to allow for complete internal inspection, unless exempted by the competent authority. The size of inspection and maintenance openings shall be determined by the need for men and machines to enter the container to inspect, maintain or repair its interior, taking into account the requirements of the competent authority. Manholes shall be a minimum of 500 mm⁵⁾ in diameter.

5.8.5.2 When opening(s) for loading or discharging comply with the size requirements of 5.8.5.1, the provision of access opening(s) is not required.

5.9 Construction

5.9.1 The container materials shall be suitable for, or adequately protected from, the cargo and the environment in which the container may be operated. Due regard should be given to the problems of variations in ambient temperature, corrosive atmospheres, the possibility of uncontrolled cargo release in fire, etc.

An allowance for corrosion shall be taken into consideration where necessary.

5.9.2 The shell(s) of each hopper-type container shall be firmly secured to the structural elements of the container framework.

5.9.3 Adequate provision shall be made for the sealing of the container in accordance with international customs requirements.

5.9.4 Container types 23 and 83 shall be manufactured in such a manner as to meet the requirements of test No. 18 — Airtightness (see 6.19).

5.10 Requirements — Optional features

5.10.1 Fork-lift pockets

5.10.1.1 Fork-lift pockets for handling 1CC, 1CX, 1D and 1DX containers in the loaded or unloaded condition may be provided as optional features.

Fork-lift pockets shall not be provided on 1AA, 1A, 1AX, 1BB, 1B and 1BX containers.

5.10.1.2 Where a set of fork-lift pockets has been fitted as in 5.10.1.1, a second set of fork-lift pockets may, in addition, be provided on 1CC, 1C and 1CX containers for empty handling only.

5.10.1.3 The fork-lift pockets, where provided, shall meet the dimensional requirements specified in annex C and shall pass completely through the base structure of the container so that lifting devices may be inserted from either side. The bases of the fork-lift pockets need not be the full width of the container but shall be provided near each end of the fork-lift pockets.

5.10.2 Grappler arms or similar devices

Fixtures for handling all containers by means of grappler arms or similar devices may be provided as optional features. The dimensional requirements for such fixtures are specified in annex D.

5.10.3 Gooseneck tunnels

Gooseneck tunnels may be provided as optional features in 1AA, 1A and 1AX containers. The dimensional requirements are specified in annex E and, in addition, all other parts of the base structure shall be as specified in 5.3.

5.10.4 Walkways

Where provided, walkways shall be designed to withstand a load of 300 kg⁵⁾ uniformly distributed over an area of 600 mm × 300 mm⁵⁾.

5.10.5 Ladders

Where provided, ladders or equivalent devices shall be designed to withstand a load of 200 kg⁵⁾ on any rung.

5.10.6 Interface for external fumigation equipment

Fittings may be provided on the container for the connection of external fumigation equipment.

5) 200 kg = 440 lb; 300 kg = 660 lb; 500 mm = 20 in; 600 mm × 300 mm = 24 in × 12 in

5.10.7 Sanitation (where required)

5.10.7.1 Attention shall be given to the need for the proper choice of materials for container construction to prevent adverse effects on the bulk cargo.

Sanitation of containers may be subject to additional international or national requirements as applied by competent authorities.

5.10.7.2 The interior surface and the container structure shall be so constructed as to facilitate thorough cleaning, and the surface shall not be functionally affected by cleaning methods normally used, such as wet steam cleaning and detergents.

5.10.7.3 The interior surface of the container structure shall be so constructed that there are no crevices or unsealed seams that could become a source of infestation.

6 Testing

6.1 General

Unless otherwise stated, containers complying with the design requirements specified in clause 5 shall, in addition, be capable of withstanding the tests specified in 6.2 to 6.19 as applicable.

The test for weatherproofness (test No. 13) shall be made after the structural tests No. 1 to No. 12, No. 14, No. 15 and No. 16, with the airtightness test No. 18, when required, being carried out last.

A container intended for the carriage of dangerous goods shall, in addition, comply with the testing requirements of the relevant regulations to the satisfaction of the competent authority.

6.1.1 The symbol P denotes the maximum payload of the container to be tested, that is

$$P = R - T$$

where

R is the rating;

T is the tare.

NOTE 5 R , P and T , by definition, are in units of mass. Where test requirements are based on the gravitational forces derived from these values, those forces, which are inertial forces, are indicated thus:

$$R_g, P_g, T_g$$

the units of which are in newtons or multiples thereof.

The word "load", when used to describe a physical quantity to which units may be ascribed, implies mass.

The word "loading", for example as in "internal loading", implies force.

6.1.2 The test loads or loadings within the container shall be uniformly distributed.

The hopper-type container under test, unless otherwise stated, shall be loaded with a suitable fluid/dry bulk to achieve the test load or loading specified.

If the test load or loading cannot readily be met by the above method, or if such a method is undesirable, the hopper-type container shall be loaded with a suitable fluid/dry bulk and a supplementary load or loading shall be applied. The total load or loading thus applied shall be such as to simulate uniform loading.

Variations of 20 % of the calculated bending moment of the uniformly loaded hopper-type container shall be considered acceptable.

NOTE 6 Other alternative test loads or loadings (for example for longitudinal and lateral internal restraint tests) may be used, provided that they achieve the specified test loading.

6.1.3 The test loads and loadings specified in all of the following tests are minimum requirements.

6.1.4 The dimensional requirements to which reference is made in the requirements sub-clause after each test are those specified in

- a) the dimensional and design requirement clauses 4 and 5 of this part of ISO 1496;
- b) ISO 668;
- c) ISO 1161.

6.2 Test No. 1 — Stacking

6.2.1 General

This test shall be carried out to prove the ability of a fully loaded container to support a superimposed mass of containers, taking into account conditions aboard ships at sea and the relative eccentricities between superimposed containers.

The test force to be applied to each pair of corner fittings and the superimposed mass that the test force represents are specified in table 2.

6.2.2 Procedure

The container shall be placed on four level pads, one under each bottom corner fitting. The pads shall be centralized under the fittings, and shall be substantially of the same plan dimensions as the fittings.

The container shall have a load uniformly distributed in such a way that the combined mass of the container and the test load is equal to $1,8R$.

The container shall be subjected to vertical forces applied either to all four corner fittings simultaneously or to each pair of end fittings, at the appropriate level specified in table 2.

The forces shall be applied through a test fixture equipped with corner fittings as specified in ISO 1161, or equivalent fittings which have imprints of the same geometry (i.e. with the same external dimensions, chamfered aperture and rounded edges) as the lower face of the bottom corner fitting specified in ISO 1161. If equivalent fittings are used, they shall be designed to produce the same effect on the container under the test loads, as when corner fittings are used.

In all cases, the forces shall be applied in such a manner that rotation of the planes through which the forces are applied and on which the container is supported is minimized.

Each corner fitting or equivalent test fitting shall be offset in the same direction by 25,4 mm⁶⁾ laterally and 38 mm⁶⁾ longitudinally.

6.2.3 Requirements

On completion of the test, the container shall show neither permanent deformation nor abnormality which will render it unsuitable for use, and the dimensional requirements affecting handling, securing and interchange shall be satisfied.

6.3 Test No. 2 — Lifting from the four top corner fittings

6.3.1 General

This test shall be carried out to prove the ability of a container, other than a 1D or a 1DX container, to

withstand being lifted from the four top corner fittings, with the lifting forces applied vertically, and the ability of a 1D or a 1DX container to withstand being lifted from the top corner fittings with the lifting forces applied at any angle between the vertical and 60° to the horizontal. These are the only recognized ways of lifting these containers by the four top corner fittings.

This test shall also be regarded as proving the ability of the floor and the base structure to withstand the forces arising from the acceleration of the payload in lifting operations.

6.3.2 Procedure

The container shall have a load uniformly distributed over the floor in such a way that the combined mass of the container and test load is equal to $2R$, and it shall be carefully lifted from all four top corners in such a way that no significant acceleration or deceleration forces are applied.

For a container other than 1D or 1DX, the lifting forces shall be applied vertically.

For a 1D or a 1DX container, lifting shall be carried out by means of slings, the angle of each leg being at 60° to the horizontal.

After lifting, the container shall be suspended for 5 min and then lowered to the ground.

6.3.3 Requirements

On completion of the test, the container shall show neither permanent deformation nor abnormality which will render it unsuitable for use, and the dimensional requirements affecting handling, securing and interchange shall be satisfied.

Table 2 — Forces to be applied in stacking test

Container designation	Test force per container (all four corners simultaneously)		Test force per pair of end fittings		Superimposed mass represented by test force	
	kN	lbf	kN	lbf	kg	lb
1AA, 1A and 1AX	3 392	763 200	1 696	381 600	192 000	423 320
1BB, 1B and 1BX	3 392	763 200	1 696	381 600	192 000	423 320
1CC, 1C and 1CX	3 392	763 200	1 696	381 600	192 000	423 320
1D and 1DX	896	201 600	448	100 800	50 800	112 000

NOTE — The test force of 3 392 kN per container is derived from the superimposed mass of nine-high stacking, i.e. eight containers stacked on top of one container, all being rated to 24 000 kg, and an acceleration of 1,8g. [The corner posts of such containers are known to have been tested to 86 400 kg (190 480 lb).]

6) 25,4 mm = 1 in; 38 mm = 1 1/2 in

6.4 Test No. 3 — Lifting from the four bottom corner fittings

6.4.1 General

This test shall be carried out to prove the ability of a container to withstand being lifted, from its four bottom corner fittings, by means of lifting devices bearing on the bottom corner fittings only and attached to a single transverse central spreader beam above the container.

6.4.2 Procedure

The container shall have a load uniformly distributed over the floor in such a way that the combined mass of container and test load is equal to $2R$, and shall be carefully lifted from the side apertures of all four bottom corner fittings in such a way that no significant acceleration or deceleration forces are applied.

Lifting forces shall be applied at

30° to the horizontal for 1AA, 1A and 1AX containers;

37° to the horizontal for 1BB, 1B and 1BX containers;

45° to the horizontal for 1CC, 1C and 1CX containers;

60° to the horizontal for 1D and 1DX containers.

In each case, the line of action of the lifting force and the outer face of the corner fitting shall be no further apart than 38 mm⁷⁾. The lifting shall be carried out in such a manner that the lifting devices bear on the four bottom corner fittings only.

The container shall be suspended for 5 min and then lowered to the ground.

6.4.3 Requirements

On completion of the test, the container shall show neither permanent deformation nor abnormality which will render it unsuitable for use, and the dimensional requirements affecting handling, securing and interchange shall be satisfied.

6.5 Test No. 4 — External restraint (longitudinal)

6.5.1 General

This test shall be carried out to prove the ability of a container to withstand longitudinal external restraint under dynamic conditions of railway operations, which implies acceleration of $2g$.

7) 38 mm = 1 1/2 in

6.5.2 Procedure

The container shall have a load uniformly distributed over the floor in such a way that the combined mass of container and test load is equal to R , and it shall be secured longitudinally to rigid anchor points through the bottom apertures of the bottom corner fittings at one end of the container.

A force of $2Rg$ shall be applied horizontally to the container through the bottom apertures of the other bottom corner fittings, first towards and then away from the anchor points.

6.5.3 Requirements

On completion of the test, the container shall show neither permanent deformation nor abnormality which will render it unsuitable for use, and the dimensional requirements affecting handling, securing and interchange shall be satisfied.

6.6 Test No. 5 — Strength of end walls (box type only)

6.6.1 General

This test shall be carried out to prove the ability of a container to withstand forces under the dynamic conditions referred to in 6.5.1.

6.6.2 Procedure

The container shall have each end tested when one end is blind or equipped with a flap door at floor level and the other equipped with doors. In the case of symmetrical construction, one end only need be tested.

The containers shall be subjected to an internal loading of

$0,4Pg$ for 1AA, 1A, 1AX, 1BB, 1B and 1BX containers;

$0,6Pg$ for 1CC, 1C, 1CX, 1D and 1DX containers.

The internal loading shall be uniformly distributed over the wall under test and arranged to allow free deflection of the wall.

6.6.3 Requirements

On completion of the test, the container shall show neither permanent deformation nor abnormality which will render it unsuitable for use, and the dimensional requirements affecting handling, securing and interchange shall be satisfied.

6.7 Test No. 6 — Strength of side walls (box type only)

6.7.1 General

This test shall be carried out to prove the ability of a container to withstand the forces resulting from ship movement.

6.7.2 Procedure

The container shall have each side wall tested. In the case of symmetrical construction, one side only need be tested.

Each side wall of the container shall be subjected to an internal loading of $0,6P_g$. The internal loading shall be uniformly distributed, applied to each wall separately and arranged to allow free deflection of the side wall and its longitudinal members.

Compliance with the requirements of 5.6.1 shall be checked under full test load.

6.7.3 Requirements

On completion of the test, the container shall show neither permanent deformation nor abnormality which will render it unsuitable for use, and the dimensional requirements affecting handling, securing and interchange shall be satisfied.

6.8 Test No. 7 — Strength of the roof (where provided)

6.8.1 General

This test shall be carried out to prove the ability of the rigid roof of a container to withstand the loads imposed by persons working on it.

6.8.2 Procedure

A load of 300 kg⁸⁾ shall be uniformly distributed over an area of 600 mm × 300 mm⁸⁾ located at the weakest area of the rigid roof of the container.

6.8.3 Requirements

On completion of the test, the container shall show neither permanent deformation nor abnormality which will render it unsuitable for use, and the dimensional requirements affecting handling, securing and interchange shall be satisfied.

6.9 Test No. 8 — Floor strength (box type only)

6.9.1 General

This test shall be carried out to prove the ability of a container floor to withstand the concentrated dynamic loading imposed during cargo operations involving powered industrial trucks or similar devices.

6.9.2 Procedure

The test shall be performed using a test vehicle equipped with tyres, with an axle load of 5 460 kg⁸⁾ [i.e. 2 730 kg⁸⁾ on each of the two wheels]. It is to be so arranged that all points of contact between each wheel and a flat continuous surface lie within a rectangular envelope measuring 185 mm⁸⁾ (in a direction parallel to the axle of the wheel) by 100 mm⁸⁾, and that each wheel makes physical contact over an area within this envelope of not more than 142 cm²⁸⁾. The wheel width shall be nominally 180 mm⁸⁾ and the wheel centres shall be nominally 760 mm⁸⁾. The test vehicle shall be manoeuvred over the entire floor area of the container. The test shall be made with the container resting on four level supports under its four bottom corner fittings, with its base structure free to deflect.

6.9.3 Requirements

On completion of the test, the container shall show neither permanent deformation nor abnormality which will render it unsuitable for use, and the dimensional requirements affecting handling, securing and interchange shall be satisfied.

6.10 Test No. 9 — Rigidity (transverse)

6.10.1 General

This test shall be carried out to prove the ability of a container, other than a 1D or a 1DX container, to withstand the transversal racking forces resulting from ship movement.

6.10.2 Procedure

The container in tare condition (*T*) shall be placed on four level supports, one under each corner fitting, and shall be restrained against lateral and vertical movement by means of anchor devices acting through the bottom apertures of the bottom corner fittings. Lateral restraint shall be provided only at a bottom corner fitting diagonally opposite and in the same end frame as the top corner fitting to which force is applied. When testing the two end frames separately, vertical restraint shall be applied only at the end frame under test.

8) 142 cm² = 22 in²; 300 kg = 660 lb; 2 730 kg = 6 000 lb; 5 460 kg = 12 000 lb; 100 mm = 4 in; 180 mm = 7 in; 185 mm = 7 1/4 in; 760 mm = 30 in; 600 mm × 300 mm = 24 in × 12 in

Forces of 150 kN⁹⁾ shall be applied either separately or simultaneously to each of the top corner fittings on one side of the container in lines parallel both to the base of the container and to the planes of the ends of the container. The forces shall be applied first towards and then away from the top corner fittings.

In the case of a container with identical ends, only one end need be tested. Where an end is not essentially symmetrical about its own vertical centre-line, both sides of that end shall be tested.

For allowable deflections under full test loading, see 5.4.

6.10.3 Requirements

On completion of the test, the container shall show neither permanent deformation nor abnormality which will render it unsuitable for use, and the dimensional requirements affecting handling, securing and interchange shall be satisfied.

6.11 Test No. 10 — Rigidity (longitudinal)

6.11.1 General

This test shall be carried out to prove the ability of a container, other than a 1D or 1DX container, to withstand the longitudinal racking forces resulting from ship movement.

6.11.2 Procedure

The container in tare condition (*T*) shall be placed on four level supports, one under each corner fitting, and shall be restrained against longitudinal and vertical movement by means of anchor devices acting through the bottom apertures of the bottom corner fittings. Longitudinal restraint shall be provided only at a bottom corner fitting diagonally opposite and in the same side frame as the top corner fitting to which force is applied.

Forces of 75 kN⁹⁾ shall be applied either separately or simultaneously to each of the top corner fittings on one end of the container in lines parallel both to the base of the container and to the planes of the sides of the container. The forces shall be applied first towards and then away from the top corner fittings.

In the case of a container with identical sides, only one side need be tested. Where a side is not essentially symmetrical about its own vertical centre-line, both ends of that side shall be tested.

For allowable deflections under full test loading, see 5.5.

6.11.3 Requirements

On completion of the test, the container shall show neither permanent deformation nor abnormality which will render it unsuitable for use, and the dimensional requirements affecting handling, securing and interchange shall be satisfied.

6.12 Test No. 11 — Lifting from fork-lift pockets (where provided)

6.12.1 General

This test shall be carried out on any 1CC, 1C, 1CX, 1D or 1DX container which is fitted with fork-lift pockets.

6.12.2 Procedure

6.12.2.1 1CC, 1C, 1CX, 1D or 1DX containers fitted with one set of fork-lift pockets

The container shall have a load uniformly distributed over the floor in such a way that the combined mass of container and test load is equal to $1,6R$ and it shall be supported on two horizontal bars, each 200 mm⁹⁾ wide, projecting $1\,828\text{ mm} \pm 3\text{ mm}^9)$ into the fork-lift pockets, measured from the outside face of the side of the container. The bars shall be centred within the pockets.

The container shall be supported for 5 min and then lowered to the ground.

6.12.2.2 1CC, 1C and 1CX containers fitted with two sets of fork-lift pockets

The test described in 6.12.2.1 shall be applied to the outer pockets.

A second test shall be applied to the (additional) inner pockets. The procedure for this second test shall be as required in 6.12.2.1 except that in this case the combined mass of the container and test load shall be equal to $0,625R$ and the bars shall be placed in the inner pockets.

6.12.3 Requirements

On completion of the test, the container shall show neither permanent deformation nor abnormality which will render it unsuitable for use, and the dimensional requirements affecting handling, securing and interchange shall be satisfied.

9) 75 kN = 16 850 lbf; 150 kN = 33 700 lbf; 200 mm = 8 in; $1\,828\text{ mm} \pm 3\text{ mm} = 72\text{ in} \pm 1/8\text{ in}$

6.13 Test No. 12 — Lifting from the base at grappler-arm positions (where provided)

6.13.1 General

This test shall be carried out on any container which is provided with fixtures for being lifted by grappler arms or similar devices with lifting positions as detailed in annex D.

6.13.2 Procedure

The container shall have a load uniformly distributed over the floor in such a way that the combined mass of container and test load is equal to $1,25R$, and it shall be supported at the four positions where provision has been made for the equipment envisaged in 6.13.1, over an area of $32 \text{ mm} \times 254 \text{ mm}^{10)}$ centrally located at each of the four positions, clear of the safety lips.

The container shall be supported for 5 min and then lowered to the ground.

6.13.3 Requirements

On completion of the test, the container shall show neither permanent deformation nor abnormality which will render it unsuitable for use, and the dimensional requirements affecting handling, securing and interchange shall be satisfied.

6.14 Test No. 13 — Weatherproofness

6.14.1 Procedure

A stream of water shall be applied to all exterior joints and seams of the container from a nozzle of inside diameter $12,5 \text{ mm}^{10)}$, at a pressure of about $100 \text{ kPa}^{10)}$ [corresponding to a head of about $10 \text{ m}^{10)}$ of water] on the upstream side of the nozzle. The nozzle shall be held at a distance of $1,5 \text{ m}^{10)}$ from the container under test, and the stream shall be traversed at a speed of $100 \text{ mm/s}^{10)}$.

Procedures involving the use of several nozzles are acceptable provided that each joint or seam is subjected to a water loading no less than that which would be given by a single nozzle.

6.14.2 Requirements

On completion of the test, no water shall have leaked into the container.

6.15 Test No. 14 — Internal longitudinal restraint (hopper type only)

6.15.1 General

Separate tests shall be carried out to prove the ability of the container to withstand the effects of the inertia of the contents resulting from longitudinal acceleration encountered during normal transport and handling operations.

NOTES

7 The internal longitudinal restraint test No. 14 need not be performed if dynamic testing has been conducted so that end loads equal to or exceeding the static test load R were achieved.

8 The effects of vertical acceleration are deemed to be covered by tests No. 2 and No. 3.

9 Containers without longitudinal connecting members between end frames are deemed to be covered by test No. 4.

6.15.2 Procedure

The container shall be loaded in such a way that the combined mass of the container and test load is equal to R .

The container shall be positioned with its longitudinal axis vertical (a tolerance of 3° is acceptable). It shall be held in this position for 5 min either

- a) by means of supports at the lower end of the base structure of the container acting only through the two bottom corner fittings giving both vertical and horizontal securement, and by means of anchor devices acting through the corner fittings at the upper end of the base structure in such a manner as to provide horizontal restraint only; or
- b) by means of supports under the four downward-facing corner fittings.

Alternative procedure b) may be used only for those types of containers where the hopper is supported solely by the base structure of the container or where, in the opinion of the competent authority, the container is adequately tested with respect to hopper-to-framework connections by tests No. 4 and No. 10.

Containers which are not structurally symmetrical shall have both ends tested.

10) $100 \text{ kPa} = 14,5 \text{ psi}$; $12,5 \text{ mm} = 1/2 \text{ in}$; $1,5 \text{ m} = 5 \text{ ft}$; $10 \text{ m} = 33 \text{ ft}$; $32 \text{ mm} \times 254 \text{ mm} = 1 \text{ 1/4 in} \times 10 \text{ in}$; $100 \text{ mm/s} = 4 \text{ in/s}$

6.15.3 Requirements

On completion of the tests, the container shall not show leakage or permanent deformation or abnormality which will render it unsuitable for use, and the dimensional requirements affecting handling, securing and interchange shall be satisfied.

6.16 Test No. 15 — Internal lateral restraint (hopper type only)

6.16.1 General

Separate tests shall be carried out to prove the ability of the container to withstand the effects of the inertia of the contents resulting from lateral acceleration encountered during normal transport and handling operations.

NOTES

10 The effects of vertical acceleration are deemed to be covered by tests No. 2 and No. 3.

11 Containers without longitudinal connecting members between end frames are deemed to be covered by test No. 4.

6.16.2 Procedure

The container shall be loaded in such a way that the combined mass of the container and test load is equal to *R*.

The container shall be positioned with its transverse axis vertical (a tolerance of 3° is acceptable). It shall be held in this position for 5 min either

- a) by means of supports at the lower end of the base structure of the container acting only through the two bottom corner fittings giving both vertical and horizontal securement, and by means of anchor devices acting through the corner fittings at the upper end of the base structure in such a manner as to provide horizontal restraint only; or
- b) by means of supports under the four downward-facing corner fittings.

Alternative procedure b) may be used only for those types of containers where the hopper is supported solely by the base structure of the container or where, in the opinion of the competent authority, the container is adequately tested with respect to container-to-framework connections by tests No. 4 and No. 9.

6.16.3 Requirements

On completion of the tests, the container shall not show leakage or permanent deformation or abnormality which will render it unsuitable for use, and the dimensional requirements affecting handling, securing and interchange shall be satisfied.

6.17 Test No. 16 — Walkways (where provided)

6.17.1 General

This test shall be carried out on all walkways, where provided on a container, to prove the ability of the walkway to withstand the loads imposed by persons working thereon.

6.17.2 Procedure

A concentrated load of not less than 300 kg¹¹⁾ shall be uniformly distributed over an area of 600 mm × 300 mm¹¹⁾ located at the weakest area of the walkway.

6.17.3 Requirements

On completion of the test, the walkways shall show neither undue deformation nor any abnormality which renders them unsuitable for use.

6.18 Test No. 17 — Ladders (where provided)

6.18.1 General

This test shall be carried out on all ladders, where provided on a container, to prove the ability of the ladder to withstand the loads imposed by persons working thereon.

6.18.2 Procedure

A load of 200 kg¹¹⁾ shall be positioned at the centre of the widest rung.

6.18.3 Requirements

On completion of the test, the ladders shall show neither undue deformation nor abnormality which would render them unsuitable for use.

11) 200 kg = 440 lb; 300 kg = 660 lb; 600 mm × 300 mm = 24 in × 12 in

6.19 Test No. 18 — Airtightness test (type codes 23 and 83)

6.19.1 General

This test, when required, shall be carried out after all structural tests have been completed.

6.19.2 Procedure

The container shall be in its normal operating condition and shall be closed in the normal manner. An air supply through a metering device and a suitable manometer shall be connected to the container by a leak-proof connection. The manometer shall not be part of the air supply system. The flow-measuring device shall be accurate to $\pm 3\%$ of the measured flow rate, and the manometer on the container shall be accurate to $\pm 5\%$.

Air shall be admitted to the container to raise the internal pressure to $250 \text{ Pa} \pm 10 \text{ Pa}^{12)}$ and the air

supply regulated to maintain this pressure. Once steady test conditions have been established, the air flow required to maintain this pressure shall be recorded.

6.19.3 Requirements

The air leakage rate, under standard atmospheric conditions, shall be no more than the values specified in table 3.

Table 3 — Air leakage rates

Freight container designation	1AA, 1A and 1AX	1BB, 1B and 1BX	1CC, 1C and 1CX	1D and 1DX
Air leakage rate, m ³ /h	30	25	20	15

12) $250 \text{ Pa} \pm 10 \text{ Pa} = 25 \text{ mmH}_2\text{O} \pm 1 \text{ mmH}_2\text{O}$

Annex A
(normative)

Diagrammatic representation of capabilities appropriate to all types and sizes of dry bulk non-pressurized containers, except where otherwise stated

NOTES

12 The externally applied forces shown below are for one end or one side only. The loads shown within the containers represent uniformly distributed internal loads only, and such loads are for the whole container.

13 The figures in this annex correspond to the tests described in 6.2 to 6.16 only where marked.

14 For definitions of R , P and T , see 6.1.1.

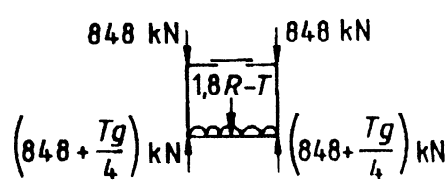
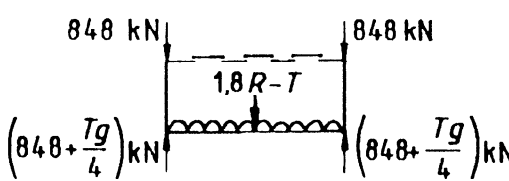
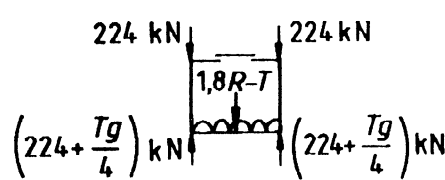
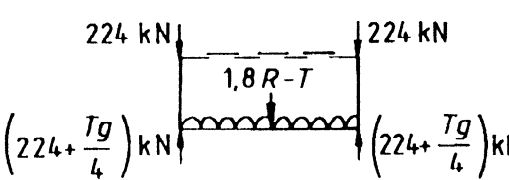
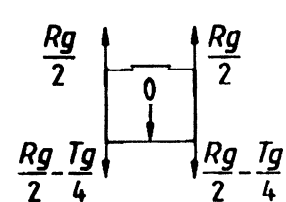
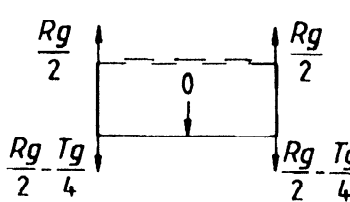
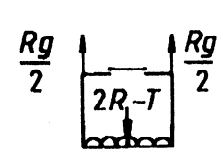
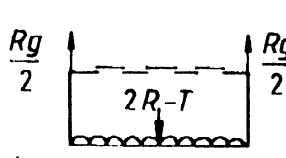
Figure No.	End elevations	Side elevations
A.1	<p>Stacking Test No. 1</p>  <p>Not applicable to 1D and 1DX containers</p>	
A.1A	<p>Stacking Test No. 1</p>  <p>Applicable to 1D and 1DX containers only</p>	
A.2	<p>Top lift</p> 	
A.3	<p>Top lift Test No. 2</p>  <p>Not applicable to 1D and 1DX containers</p>	

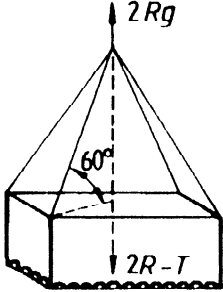
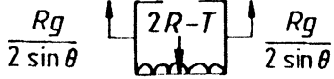
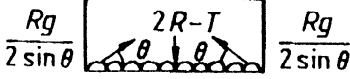


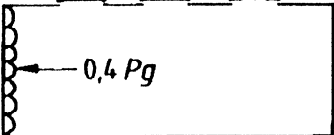
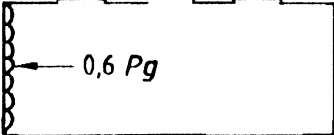
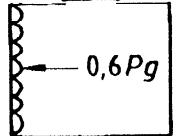
Figure No.	End elevations	Side elevations
A.3A	<p>Top lift Test No. 2</p>  <p>Applicable to 1D and 1DX containers only</p>	
A.4	<p>Bottom lift Test No. 3</p> 	
A.5	<p>Restraint (longitudinal) Test No. 4</p>	
A.5A		
A.6	<p>End loading Test No. 5</p> <p>Applicable to 1AA, 1A, 1AX, 1BB, 1B and 1BX containers</p>	
A.6A	<p>End loading Test No. 5</p> <p>Applicable to 1CC, 1C, 1CX, 1D and 1DX containers</p>	
A.7	<p>Side loading Test No. 6</p> 	

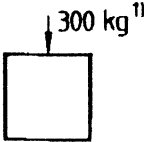
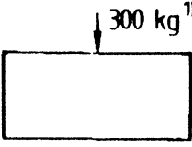
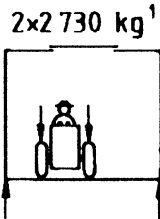
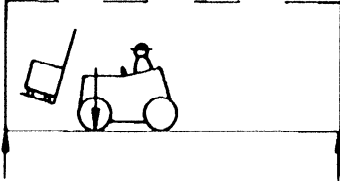
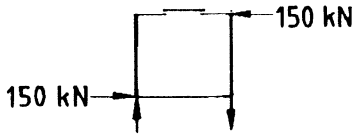
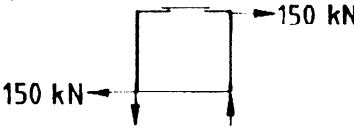
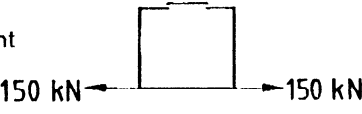
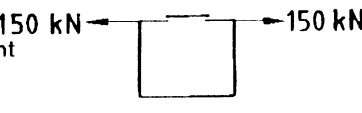
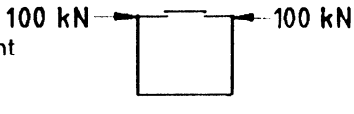

Figure No.	End elevations	Side elevations
A.8	Roof load Test No. 7 	
A.9	Wheel loads Test No. 8 	
A.10	Rigidity (transverse) Test No. 9 	Not applicable to 1D and 1DX containers
A.10A	Rigidity (transverse) Test No. 9 	
A.11	Lashing/securement 	
A.12	Lashing/securement 	
A.13	Lashing/securement 	
A.14	Lashing/securement 	
1) 300 kg = 660 lb 2 x 2 730 kg = 2 x 6 000 lb		

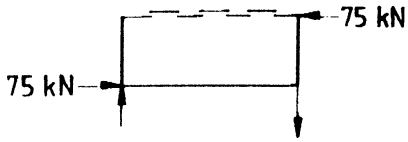
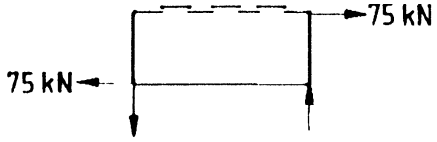

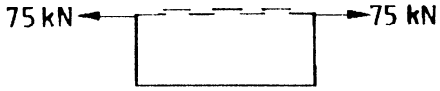
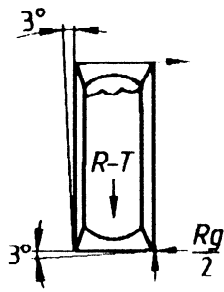
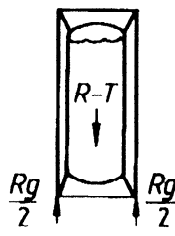
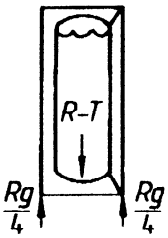
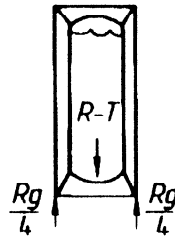
Figure No.	End elevations	Side elevations
A.15	Rigidity (longitudinal) Test No. 10	
A.15A	Not applicable to 1D and 1DX containers	
A.16	Lashing/securement (This type of loading is inadmissible except as applied in A.3A)	
A.17	Lashing/securement Not applicable to 1D and 1DX containers	
Applicable to hopper type only		
A.18	Internal longitudinal restraint Test No. 14 [see 6.15.2 a)] 	 <p style="text-align: center;">Frame connections through all corner fittings</p>
A.18A	Internal longitudinal restraint Test No. 14 [see 6.15.2 b)] 	 <p style="text-align: center;">Frame connections through bottom structure only</p>

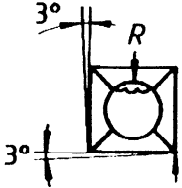
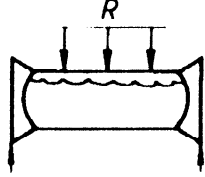
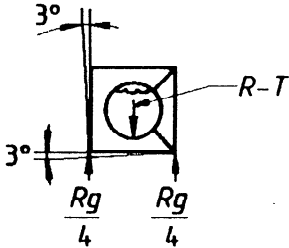
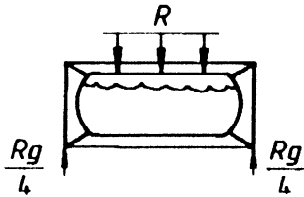
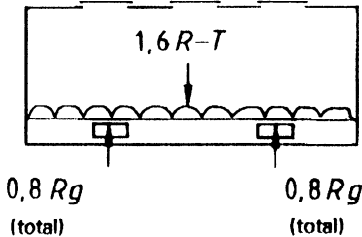
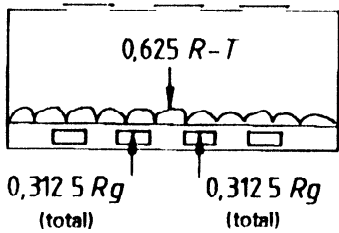
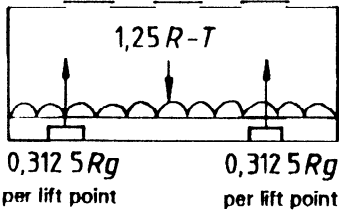
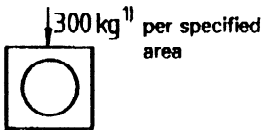
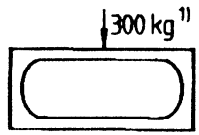
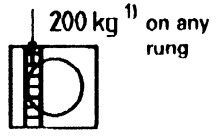
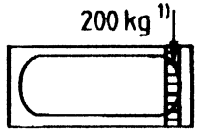
Figure No.	End elevations	Side elevations
A.19	<p>Internal lateral restraint Test No. 15 [see 6.16.2 a)]</p>  <p>Frame connections through all corner fittings</p>	
A.19A	<p>Internal lateral restraint Test No. 15 [see 6.16.2 b)]</p>  <p>Frame connections through bottom structure only</p>	
A.20	<p>Fork-lift pockets Test No. 11</p> <p>Applicable to 1CC, 1C, 1CX, 1D and 1DX containers when fitted with one set of fork-lift pockets</p>	
A.20A	<p>Fork-lift pockets Test No. 11</p> <p>Applicable to 1CC, 1C and 1CX containers when fitted with a second set of fork-lift pockets</p>	
A.21	<p>Grapppler-arm lift Test No. 12</p> <p>Applicable to all sizes when fitted with grapppler-arm lift positions</p>	

Figure No.	End elevations	Side elevations
A.22	<p>Walkways Test No. 16</p>  <p>(where walkways are provided)</p>	
A.23	<p>Ladders Test No. 17</p>  <p>(where ladders are provided)</p>	
<p>1) 300 kg = 660 lb 200 kg = 440 lb</p>		

Annex B (normative)

Details of requirements for load-transfer areas in base structures of containers

B.1 The base structures of containers, i.e. the end transverse members and such intermediate members as may be fitted (or such flat undersides as may be provided) to constitute load-transfer areas, shall be capable of transferring load to or from the longitudinal members of a carrying vehicle which are assumed to lie within the two 250 mm¹³⁾ wide zones defined (by the broken lines) in figure B.1.

B.2 Containers not having transverse members spaced 1 000 mm¹³⁾ apart or less (and not having a flat underside) shall have load-transfer areas as indicated in figures B.2, B.3, B.4 and B.5, capable of meeting the following requirements.

B.2.1 Each pair of load-transfer areas associated with an end transverse member shall be capable of transferring loads of not less than 0,5*R*, i.e. the loads which may occur when a container is placed on to a carrying vehicle of the kind which does not support the container by its corner fittings.

Furthermore, each pair of intermediate load-transfer areas shall be capable of transferring loads of not less than 1,5*R*/*n*, where *n* is the number of pairs of intermediate load-transfer areas, i.e. loads which may occur during transport operations.

B.2.2 The minimum number of pairs of load-transfer areas are:

For 1CC, 1C and 1CX containers	4
For 1BB, 1B and 1BX containers	5

For 1AA, 1A and 1AX containers	5
For 1AA, 1A and 1AX containers fitted with a non-continuous gooseneck tunnel	6

Where a greater number of pairs of load-transfer areas are provided, these should be approximately equally spaced along the length of the container.

B.2.3 The spacing between the end transverse member and the nearest intermediate pair of load-transfer areas shall be:

- 1 700 mm to 2 000 mm¹³⁾ for containers having the minimum number of pairs of load-transfer areas for the container concerned;
- 1 000 mm to 2 000 mm¹³⁾ for containers having one more pair of load-transfer areas than the minimum required for the containers concerned.

B.2.4 Each load-transfer area shall have a longitudinal dimension of at least 25 mm¹³⁾.

B.3 Minimum requirements for load-transfer areas in the vicinity of the gooseneck tunnel are shown in figure B.6.

NOTE 15 In figures B.2, B.3, B.4 and B.5, the load-transfer areas associated with the container base are shown in black. Gooseneck tunnel transfer areas are also shown in black in figure B.6.

¹³⁾ 25 mm = 1 in; 250 mm = 10 in; 1 000 mm = 39 3/8 in; 1 000 mm to 2 000 mm = 39 3/8 in to 78 3/4 in; 1 700 mm to 2 000 mm = 66 15/16 in to 78 3/4 in

Dimensions in millimetres¹⁾

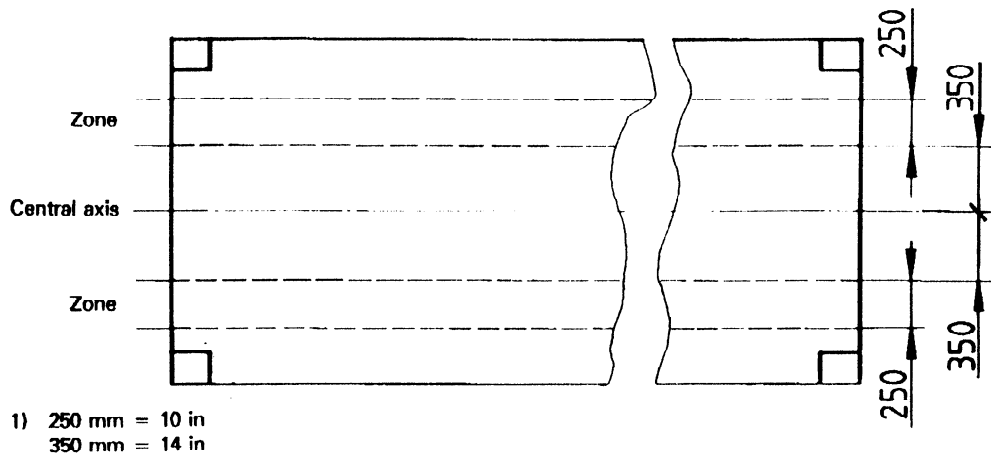
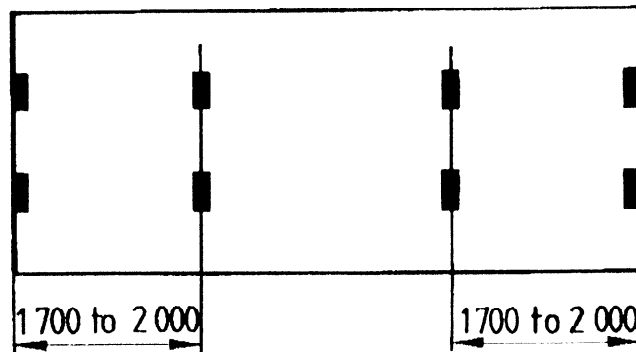


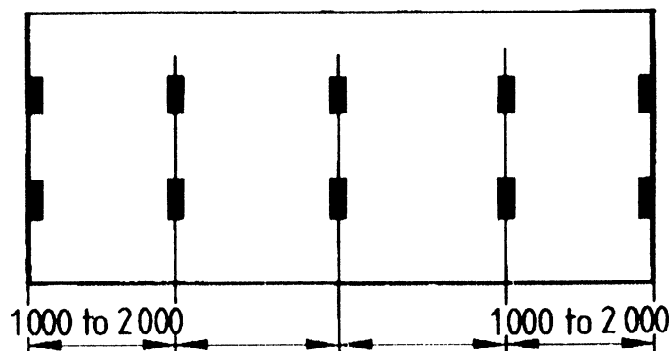
Figure B.1 — Zones for longitudinal members

Dimensions in millimetres¹⁾



4 pairs of load-transfer areas
(1 pair at each end plus 2 intermediate pairs)

a) Minimum requirements

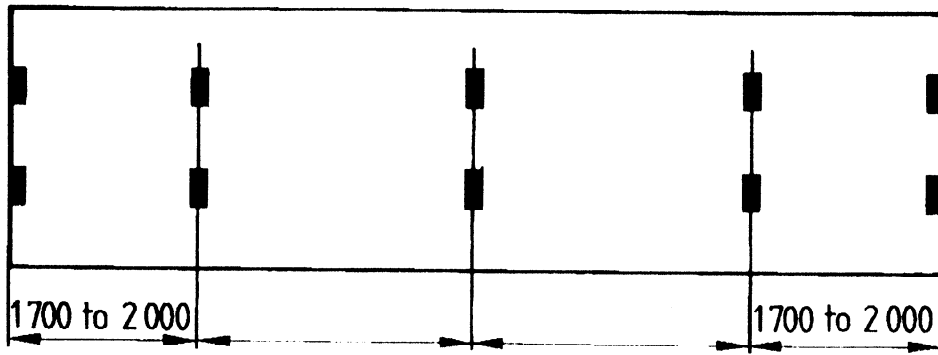


b) Requirements applicable if 5 pairs of load-transfer areas are to be fitted

- 1) 1 700 mm to 2 000 mm = 66 15/16 in to 78 3/4 in
1 000 mm to 2 000 mm = 39 3/8 in to 78 3/4 in

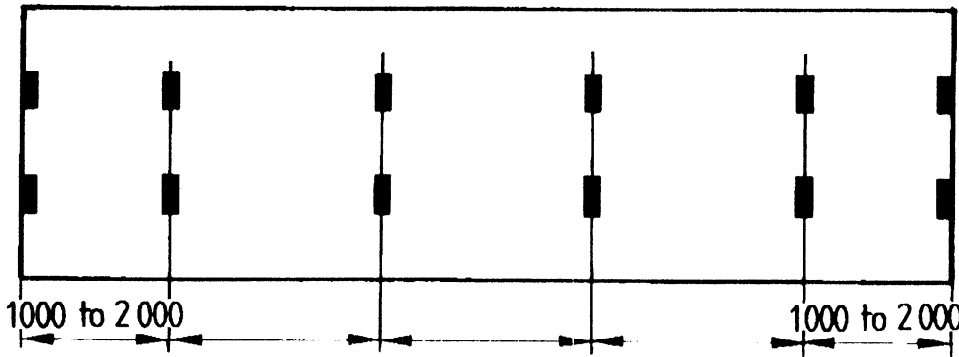
Figure B.2 — 1CC, 1C and 1CX containers

Dimensions in millimetres¹⁾



5 pairs of load-transfer areas
(1 pair at each end plus 3 intermediate pairs)

a) Minimum requirements

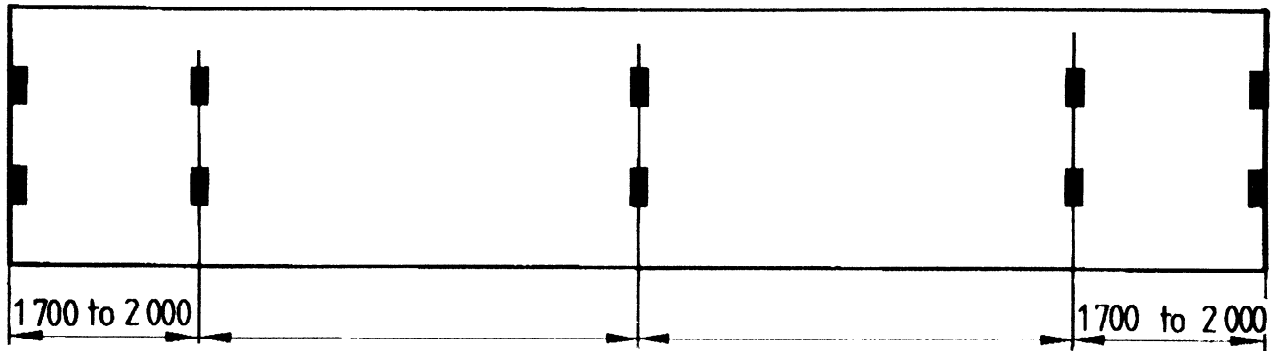


b) Requirements applicable if 6 pairs of load-transfer areas are to be fitted

- 1) 1 700 mm to 2 000 mm = 66 15/16 in to 78 3/4 in
- 1 000 mm to 2 000 mm = 39 3/8 in to 78 3/4 in

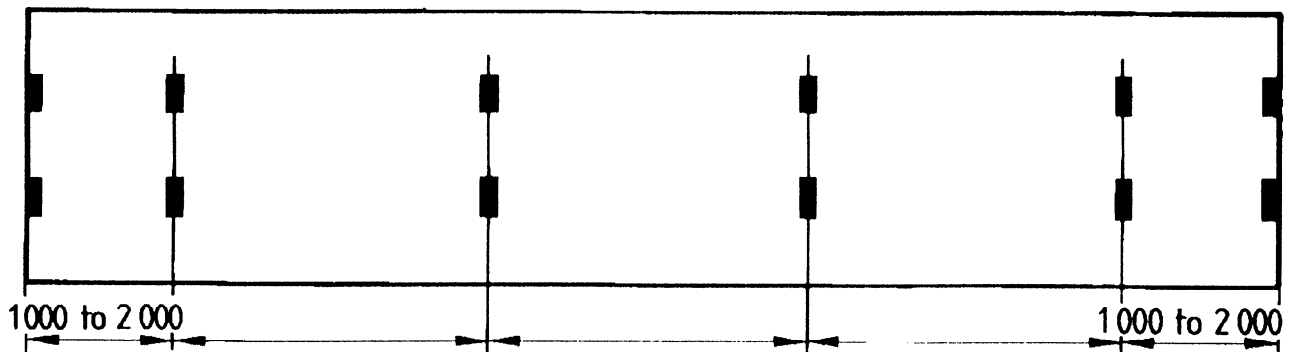
Figure B.3 — 1BB, 1B and 1BX containers

Dimensions in millimetres¹⁾



5 pairs of load-transfer areas
(1 pair at each end plus 3 intermediate pairs)

a) Minimum requirements

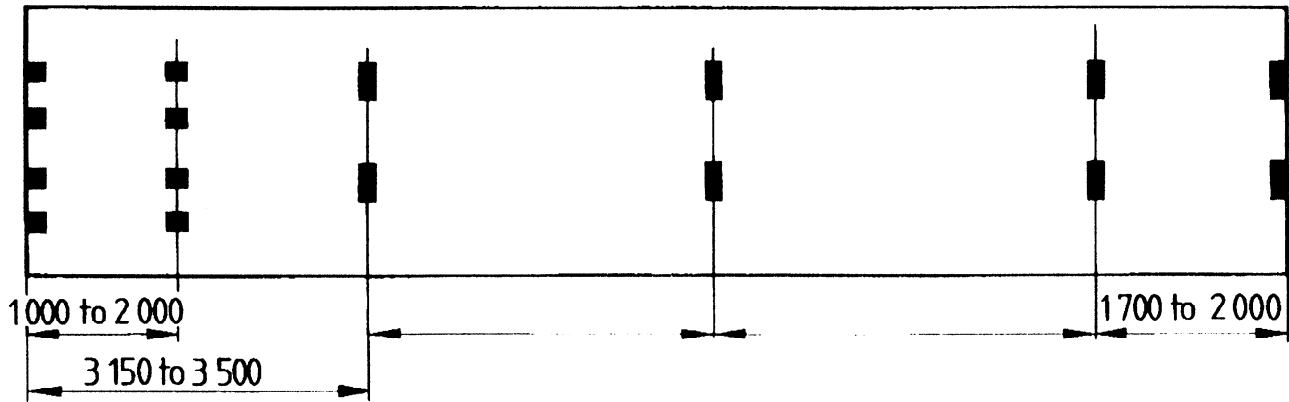


b) Requirements applicable if 6 pairs of load-transfer areas are to be fitted

- 1) 1 700 mm to 2 000 mm = 66 15/16 in to 78 3/4 in
- 1 000 mm to 2 000 mm = 39 3/8 in to 78 3/4 in

Figure B.4 — 1AA, 1A and 1AX containers without gooseneck tunnel

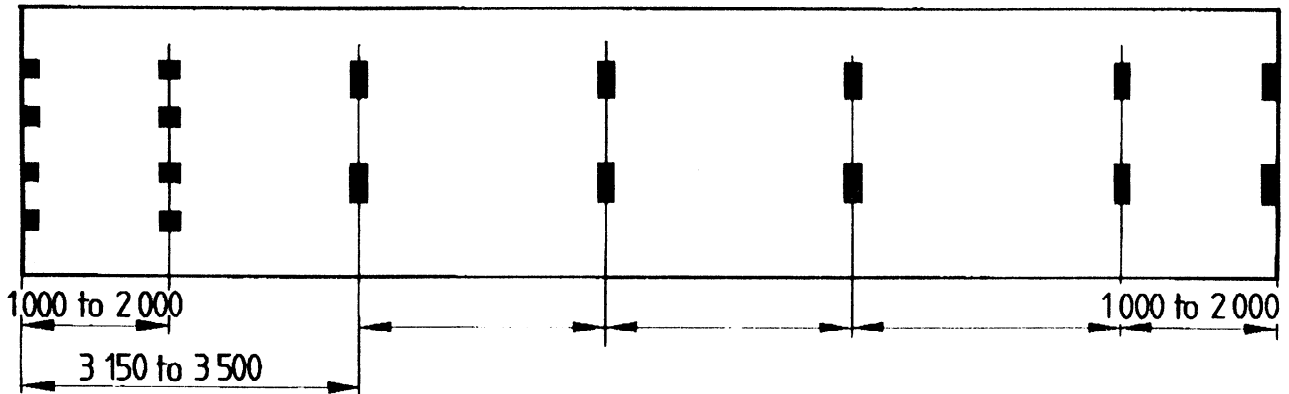
Dimensions in millimetres¹⁾



(See also figure B.6)

6 pairs of load-transfer areas
(1 pair at each end plus 4 intermediate pairs)

a) Minimum requirements



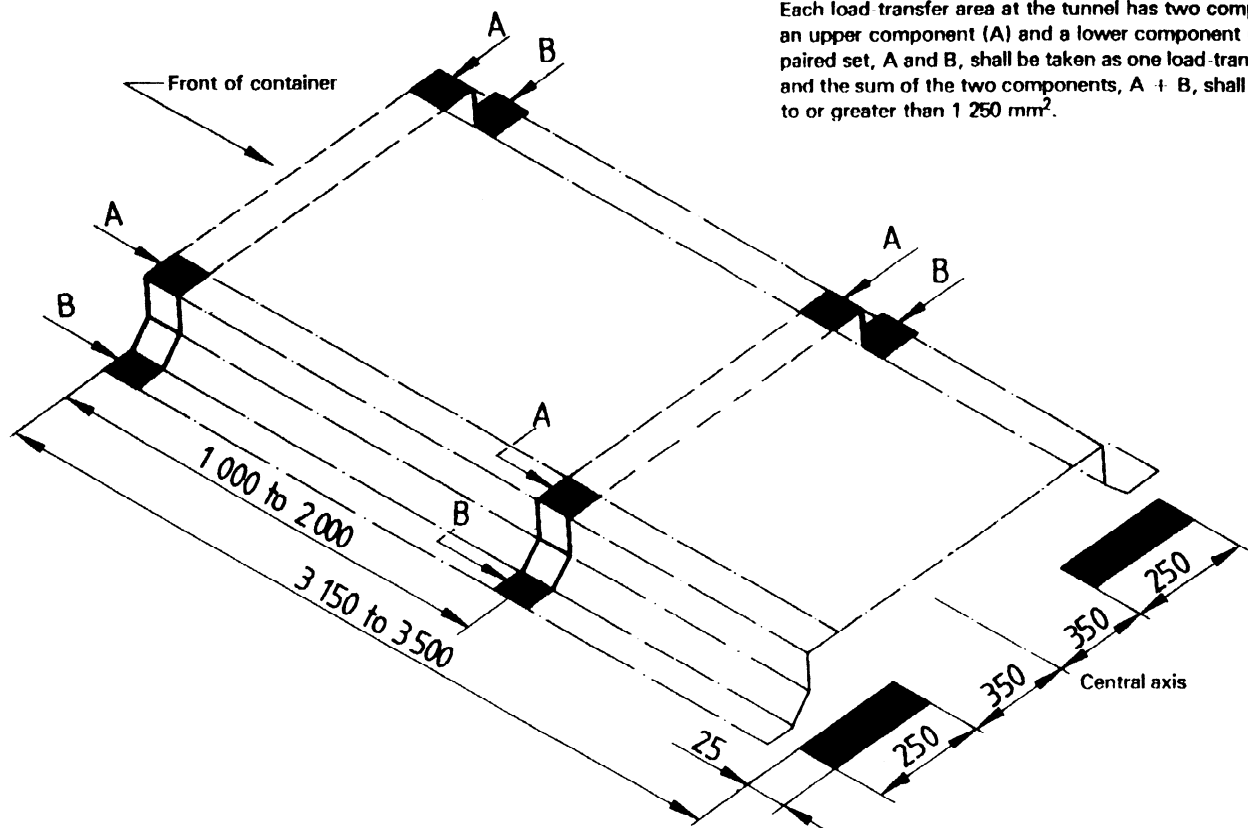
(See also figure B.6)

b) Requirements applicable if 7 pairs of load-transfer areas are to be fitted

- 1) 1 000 mm to 2 000 mm = 39³/₈ in to 78³/₄ in
- 1 700 mm to 2 000 mm = 66¹⁵/₁₆ in to 78³/₄ in
- 3 150 mm to 3 500 mm = 124¹/₄ in to 137⁷/₈ in

Figure B.5 — 1AA, 1A and 1AX containers with gooseneck tunnel (with minimum localized structure)

Dimensions in millimetres¹⁾



Each load transfer area at the tunnel has two components, an upper component (A) and a lower component (B). This paired set, A and B, shall be taken as one load-transfer area and the sum of the two components, A + B, shall be equal to or greater than 1 250 mm².

(See annex E for details of tunnel section.)

NOTE — Where continuous tunnel side members are provided, the load transfer areas situated between 3 150 mm and 3 500 mm¹⁾ from the end of the container may be omitted.

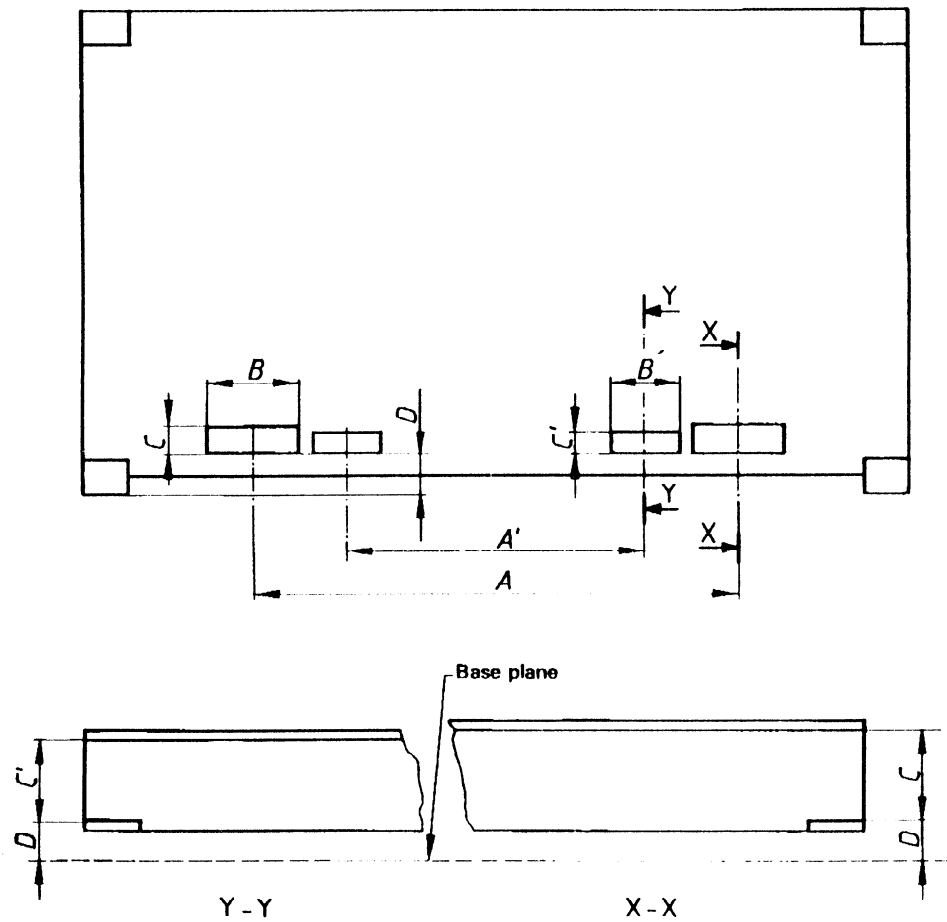
- 1) 1 250 mm² = 2 in²
- 1 000 mm to 2 000 mm = 39³/₈ in to 78³/₄ in
- 3 150 mm to 3 500 mm = 124¹/₄ in to 137⁷/₈ in
- 25 mm = 1 in
- 250 mm = 10 in
- 350 mm = 14 in

Figure B.6 — Minimum requirements for load-transfer areas near the gooseneck tunnel

Annex C
(normative)

Dimensions of fork-lift pockets (where provided)

See 5.10.1 and figure C.1.



Container	Dimensions													
	Fork-lift pockets for loaded and unloaded containers								Fork-lift pockets for unloaded containers only					
	mm				in				mm			in		
	A	B	C	D	A	B	C	D	A'	B'	C'	A'	B'	C'
1CC, 1C or 1CX	2 050 ± 50	355 min.	115 min.	20 min.	81 ± 2	14 min.	4 1/2 min.	1/32 min.	900 ± 50	305 min.	102 min.	35 1/2 ± 2	12 min.	4 min.
1D or 1DX	900 ± 50	305 min.	102 min.	20 min.	35 1/2 ± 2	12 min.	4 min.	1/32 min.						

NOTE — C = clear opening

Figure C.1

Annex D
(normative)

Dimensions of grappler-arm lifting areas (where provided)

See 5.10.2 and figure D.1.

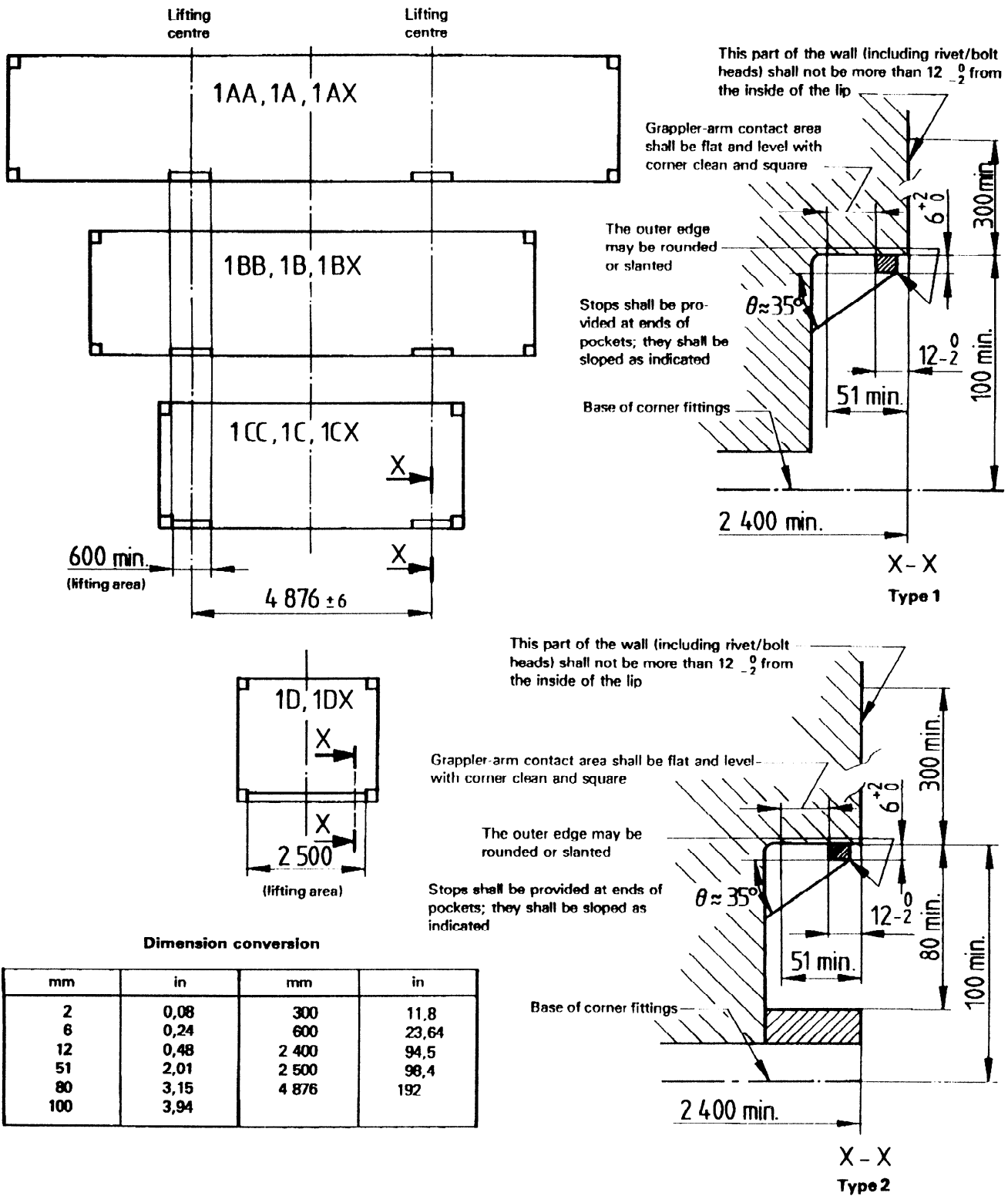
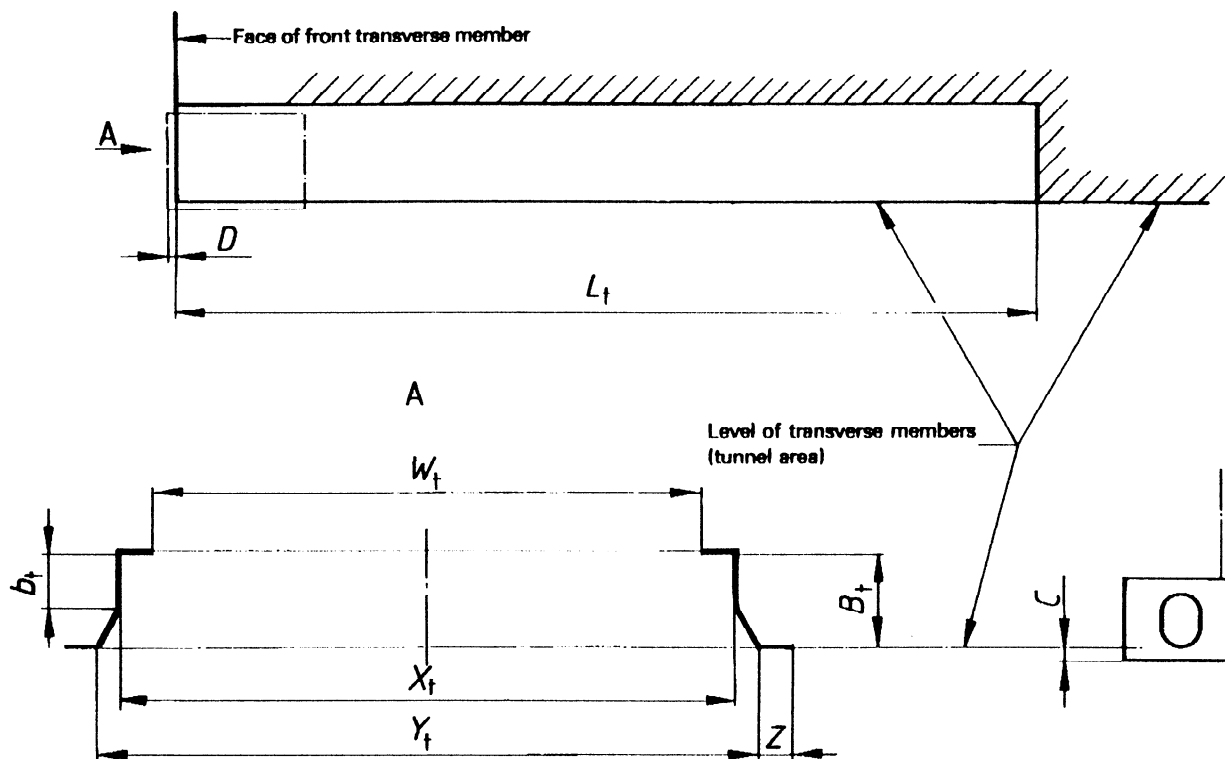


Figure D.1

Annex E
(normative)

Dimensions of gooseneck tunnels (where provided)

See 5.10.3. The space required to constitute a gooseneck tunnel into which the gooseneck of a trailer may fit is shown in figure E.1.



Dimensions	Length		Width				Height		
	L_1	D	W_t , max.	X_t	Y_t	Z , min.	B_t	b_t	C
mm	3 500 3 150	6^{+1}_{-2}	930	$1\ 029^{+3}_0$	$1\ 130$ $1\ 070$	25	120^0_{-3}	70 35	$12,5^{+5}_{-1,5}$
in	$137\ 7/8$ $124\ 1/4$	$1/4^{+3/64}_{-3/32}$	$36\ 5/8$	$40\ 1/2^{+1/8}_0$	$44\ 1/2$ $42\ 1/8$	1	$4\ 23/32^0_{-1/8}$	$2\ 3/4$ $1\ 3/8$	$1/2^{+3/16}_{-1/16}$

NOTES

- 1 Tolerance B_t shall be measured in the back part of the tunnel, over a length of about 600 mm (23 5/8 in).
- 2 The tunnel structure may be formed by continuous members having the minimum length specified in the table and the internal dimensions given for the thick lines in the figure or, alternatively, localized structures may be provided at the positions shown in black in figure B.6.

Figure E.1

Annex F
(informative)

Typical examples of the location of openings for loading of dry bulk non-pressurized box-type containers

Dimensions in millimetres

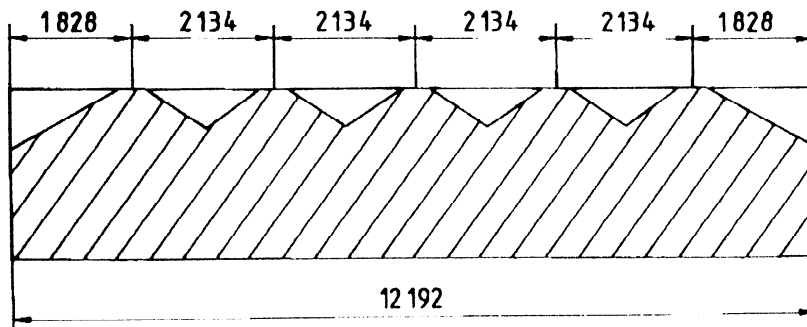


Figure F.1 — Location of openings — Series 1AA and 1A

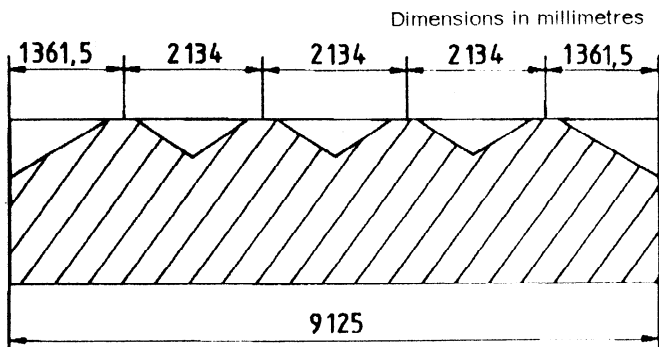


Figure F.2 — Location of openings — Series 1B

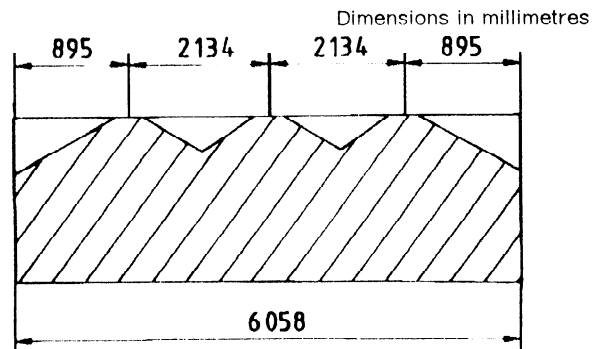


Figure F.3 — Location of openings — Series 1CC and 1C

Annex G
(informative)

Bibliography

- [1] ISO 8323:1985, *Freight containers — Air/surface (intermodal) general purpose containers — Specification and tests.*

This page intentionally left blank

This page intentionally left blank

UDC 621.869.88

Descriptors: containers, freight containers, classification, specifications, tests, performance tests.

Price based on 31 pages
