

# INTERNATIONAL STANDARD

# ISO 1478

Second edition  
1999-08-01

---

---

## Tapping screws thread

*Filetage de vis à tôle*



Reference number  
ISO 1478:1999(E)

## **Foreword**

ISO (the International Organization for Standardization) is a worldwide federation of national standards bodies (ISO member bodies). The work of preparing International Standards is normally carried out through ISO technical committees. Each member body interested in a subject for which a technical committee has been established has the right to be represented on that committee. International organizations, governmental and non-governmental, in liaison with ISO, also take part in the work. ISO collaborates closely with the International Electrotechnical Commission (IEC) on all matters of electrotechnical standardization.

International Standards are drafted in accordance with the rules given in the ISO/IEC Directives, Part 3.

Draft International Standards adopted by the technical committees are circulated to the member bodies for voting. Publication as an International Standard requires approval by at least 75 % of the member bodies casting a vote.

International Standard ISO 1478 was prepared by Technical Committee ISO/TC 2, *Fasteners*.

This second edition cancels and replaces the first edition (ISO 1478:1983) which has been technically revised.

© ISO 1999

All rights reserved. Unless otherwise specified, no part of this publication may be reproduced or utilized in any form or by any means, electronic or mechanical, including photocopying and microfilm, without permission in writing from the publisher.

International Organization for Standardization  
Case postale 56 • CH-1211 Genève 20 • Switzerland  
Internet iso@iso.ch

Printed in Switzerland

# Tapping screws thread

## 1 Scope

This International Standard specifies the thread and thread ends for tapping screws (sheet metal screws) with thread sizes from ST1,5 to ST9,5 inclusive.

## 2 Dimensions

See Figures 1 and 2 and Table 1.

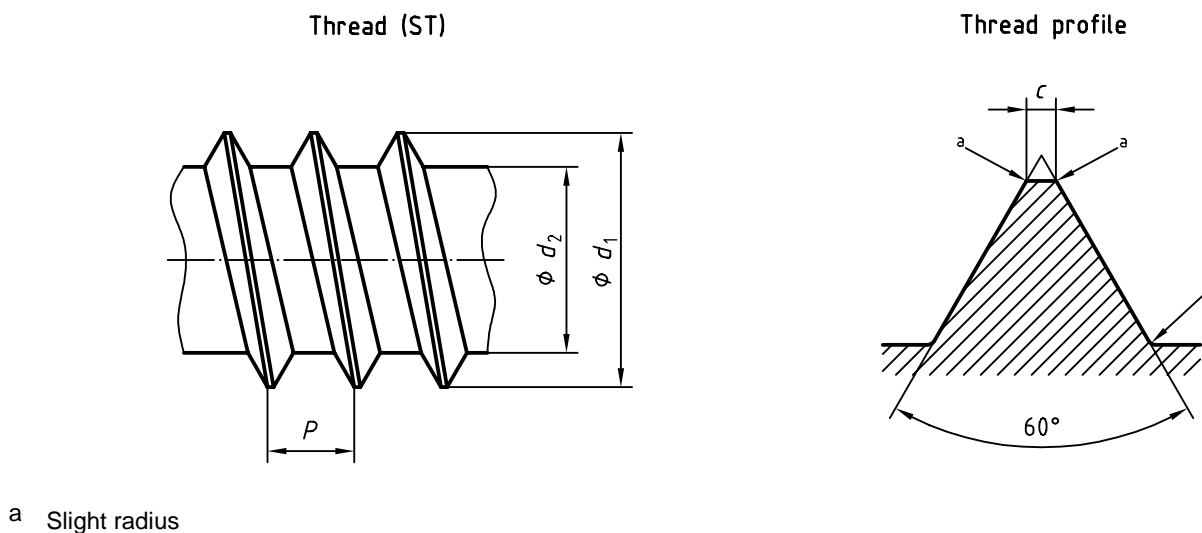
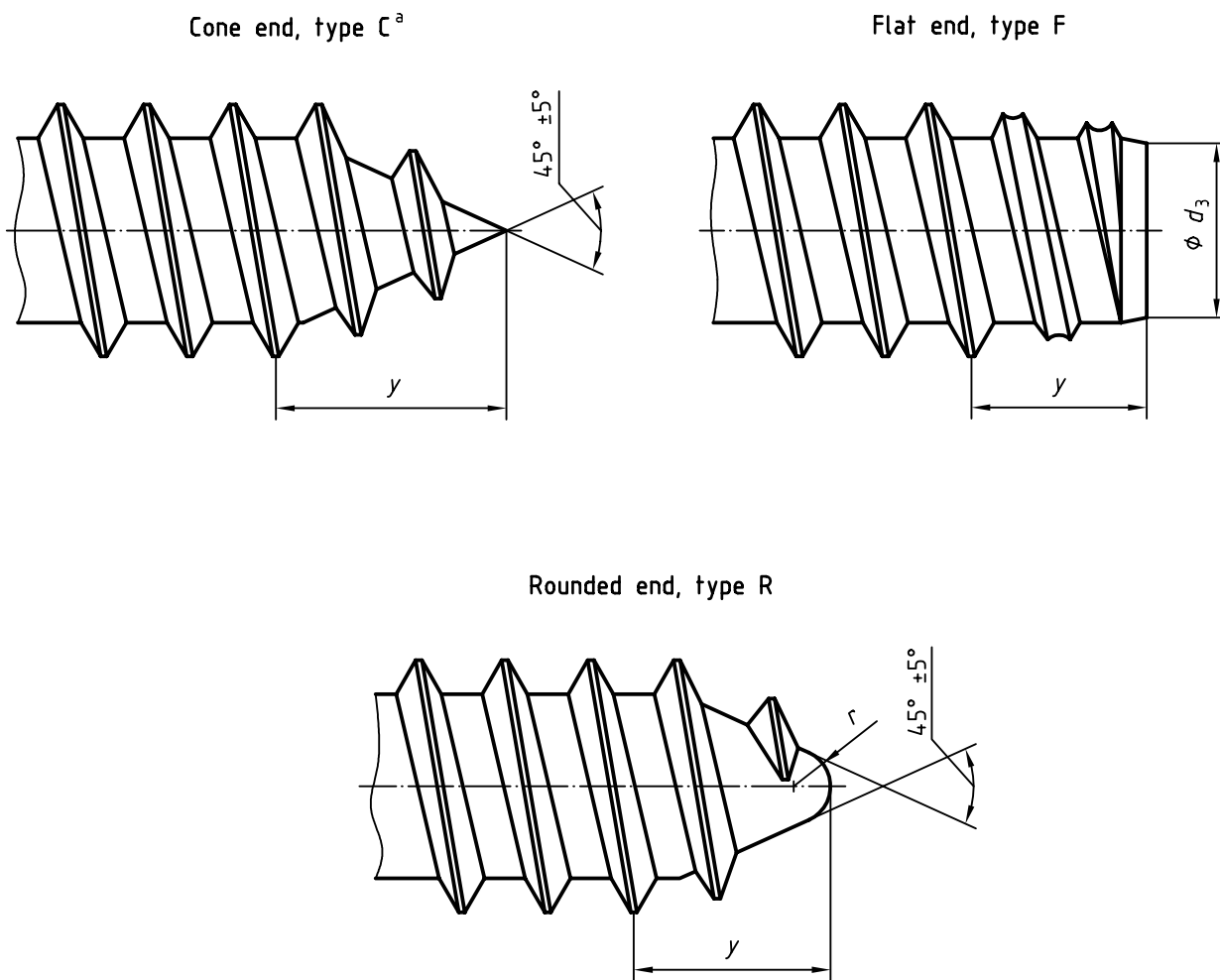

Figure 1 — Thread dimensions



<sup>a</sup> No extrusion of excess metal beyond the apex of the type C cone end resulting from thread rolling shall be permissible. A slight rounding or truncation of the point is desirable.

Figure 2 — Thread ends

<https://www.iso.org/standard/42811.html>

Table 1 — Dimensions

Dimensions in millimetres

Thread size		ST 1,5	ST 1,9	ST 2,2	ST 2,6	ST 2,9	ST 3,3	ST 3,5	ST 3,9	ST 4,2	ST 4,8	ST 5,5	ST 6,3	ST 8	ST 9,5
<i>P</i>	≈	0,5	0,6	0,8	0,9	1,1	1,3	1,3	1,3	1,4	1,6	1,8	1,8	2,1	2,1
<i>d</i> <sub>1</sub>	max.	1,52	1,90	2,24	2,57	2,90	3,30	3,53	3,91	4,22	4,80	5,46	6,25	8,00	9,65
	min.	1,38	1,76	2,10	2,43	2,76	3,12	3,35	3,73	4,04	4,62	5,28	6,03	7,78	9,43
<i>d</i> <sub>2</sub>	max.	0,91	1,24	1,63	1,90	2,18	2,39	2,64	2,92	3,10	3,58	4,17	4,88	6,20	7,85
	min.	0,84	1,17	1,52	1,80	2,08	2,29	2,51	2,77	2,95	3,43	3,99	4,70	5,99	7,59
<i>d</i> <sub>3</sub>	max.	0,79	1,12	1,47	1,73	2,01	2,21	2,41	2,67	2,84	3,30	3,86	4,55	5,84	7,44
	min.	0,69	1,02	1,37	1,60	1,88	2,08	2,26	2,51	2,69	3,12	3,68	4,34	5,64	7,24
<i>c</i>	max.	0,1	0,1	0,1	0,1	0,1	0,1	0,1	0,1	0,1	0,15	0,15	0,15	0,15	0,15
<i>r</i> <sup>a</sup>	≈	—	—	—	—	—	—	0,5	0,6	0,6	0,7	0,8	0,9	1,1	1,4
<i>y</i> ref. <sup>b</sup>	Type C	1,4	1,6	2	2,3	2,6	3	3,2	3,5	3,7	4,3	5	6	7,5	8
	Type F	1,1	1,2	1,6	1,8	2,1	2,5	2,5	2,7	2,8	3,2	3,6	3,6	4,2	4,2
	Type R	—	—	—	—	—	—	2,7	3	3,2	3,6	4,3	5	6,3	—
Number <sup>c</sup>		0	1	2	3	4	5	6	7	8	10	12	14	16	20

<sup>a</sup> Dimension *r* is a reference and has been provided for guidance only. The end may not be perfectly spherical but shall not be sharp to the touch.

<sup>b</sup> Length of incomplete thread.

<sup>c</sup> Former thread designation, for information only.

### 3 Designation

EXAMPLE A tapping screw thread with thread size ST3,5 is designated as follows:

#### Tapping screw thread ISO 1478 - ST3,5

NOTE The type of thread end should be specified within the product designation, see product standards.

---

---

**ICS 21.040.30**

Price based on 3 pages

---

---