

---

---

**Rubber, vulcanized or thermoplastic —  
Determination of low-temperature  
stiffening (Gehman test)**

*Caoutchouc vulcanisé ou thermoplastique — Détermination de la  
rigidité à basse température (Essai Gehman)*



Reference number  
ISO 1432:2013(E)

© ISO 2013



**COPYRIGHT PROTECTED DOCUMENT**

© ISO 2013

All rights reserved. Unless otherwise specified, no part of this publication may be reproduced or utilized in any form or by any means, electronic or mechanical, including photocopying and microfilm, without permission in writing from either ISO at the address below or ISO's member body in the country of the requester.

ISO copyright office  
Case postale 56 • CH-1211 Geneva 20  
Tel. + 41 22 749 01 11  
Fax + 41 22 749 09 47  
E-mail [copyright@iso.org](mailto:copyright@iso.org)  
Web [www.iso.org](http://www.iso.org)

Published in Switzerland

# Contents

	Page
<b>Foreword</b> .....	<b>iv</b>
<b>1 Scope</b> .....	<b>1</b>
<b>2 Normative references</b> .....	<b>1</b>
<b>3 Principle</b> .....	<b>1</b>
<b>4 Apparatus</b> .....	<b>1</b>
<b>5 Calibration</b> .....	<b>3</b>
<b>6 Test piece</b> .....	<b>3</b>
6.1 Preparation of test piece.....	3
6.2 Conditioning of test piece.....	3
<b>7 Procedure</b> .....	<b>4</b>
7.1 Mounting of test piece.....	4
7.2 Stiffness measurements in liquid media.....	4
7.3 Stiffness measurements in gaseous media.....	4
7.4 Crystallization.....	5
<b>8 Number of tests</b> .....	<b>5</b>
<b>9 Expression of results</b> .....	<b>5</b>
9.1 Torsional modulus.....	5
9.2 Relative modulus.....	5
9.3 Apparent torsional modulus of rigidity.....	5
<b>10 Test report</b> .....	<b>6</b>
<b>Annex A (normative) Calibration schedule</b> .....	<b>9</b>
<b>Bibliography</b> .....	<b>12</b>

## Foreword

ISO (the International Organization for Standardization) is a worldwide federation of national standards bodies (ISO member bodies). The work of preparing International Standards is normally carried out through ISO technical committees. Each member body interested in a subject for which a technical committee has been established has the right to be represented on that committee. International organizations, governmental and non-governmental, in liaison with ISO, also take part in the work. ISO collaborates closely with the International Electrotechnical Commission (IEC) on all matters of electrotechnical standardization.

International Standards are drafted in accordance with the rules given in the ISO/IEC Directives, Part 2.

The main task of technical committees is to prepare International Standards. Draft International Standards adopted by the technical committees are circulated to the member bodies for voting. Publication as an International Standard requires approval by at least 75 % of the member bodies casting a vote.

Attention is drawn to the possibility that some of the elements of this document may be the subject of patent rights. ISO shall not be held responsible for identifying any or all such patent rights.

ISO 1432 was prepared by Technical Committee ISO/TC 45, *Rubber and rubber products*, Subcommittee SC 2, *Testing and analysis*.

This fourth edition cancels and replaces the third edition (ISO 1432:1988), which has been technically revised to allow computerized instruments to be used. In addition, a calibration schedule has been added (see [Annex A](#)). It also incorporates the Technical Corrigendum ISO 1432:1988/Cor.1:2003.

.....

# Rubber, vulcanized or thermoplastic — Determination of low-temperature stiffening (Gehman test)

**WARNING** — Persons using this International Standard should be familiar with normal laboratory practice. This standard does not purport to address all of the safety problems, if any, associated with its use. It is the responsibility of the user to establish appropriate safety and health practices and to ensure compliance with any national regulatory conditions.

**CAUTION** — Certain procedures specified in this International Standard might involve the use or generation of substances, or the generation of waste, that could constitute a local environmental hazard. Reference should be made to appropriate documentation on safe handling and disposal after use.

## 1 Scope

This International Standard specifies a static procedure, known as the Gehman test, for determining the relative stiffness characteristics of vulcanized or thermoplastic rubbers over a temperature range from room temperature to approximately  $-150\text{ }^{\circ}\text{C}$ .

## 2 Normative references

The following documents, in whole or in part, are normatively referenced in this document and are indispensable for its application. For dated references, only the edition cited applies. For undated references, the latest edition of the referenced document (including any amendments) applies.

ISO 18899:2004, *Rubber — Guide to the calibration of test equipment*

ISO 23529, *Rubber — General procedures for preparing and conditioning test pieces for physical test methods*

## 3 Principle

The torsional stiffness is measured as a function of temperature, starting from a low temperature. The stiffness is measured by connecting the test piece in series with a calibrated spring wire and measuring the angle of twist of the test piece when the top of the wire is turned  $180^{\circ}$ .

## 4 Apparatus

**4.1 Torsion apparatus**, consisting of a torsion head, capable of being turned  $180^{\circ}$  in a plane normal to the torsion wire. The top of the wire is fastened to the torsion head. The bottom of the wire is fastened to the test piece clamp. A device for “friction-free” indication or recording of angle by mechanical or electrical means shall be provided, permitting convenient and exact adjustment of the zero point. The indicating or recording system shall allow reading or recording of the angle of twist to the nearest degree. This principle is shown in [Figure 1](#).

**4.2 Torsion wires**, made of tempered spring wire, of a length of  $65\text{ mm} \pm 8\text{ mm}$ , and having nominal torsional constants of  $0,7\text{ mN}\cdot\text{m}$ ,  $2,8\text{ mN}\cdot\text{m}$  and  $11,2\text{ mN}\cdot\text{m}$ . In cases of dispute, the  $2,8\text{ mN}\cdot\text{m}$  wire shall be used.

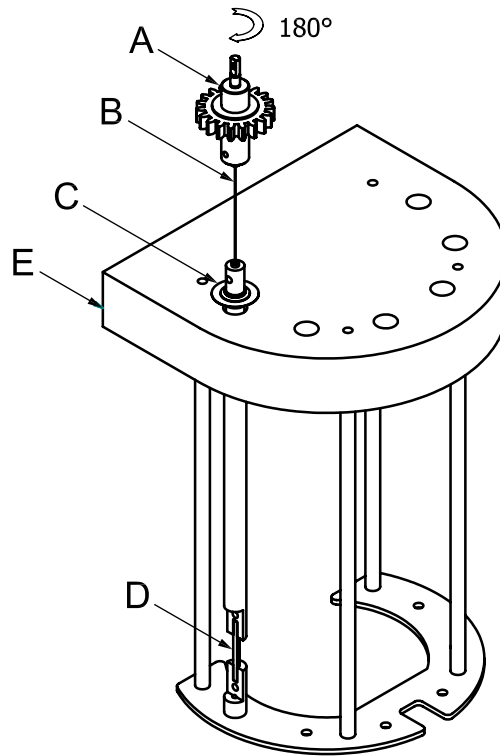

**Key**

A	torsion head
B	torsion wire
C	angle measurement
D	test piece
E	test piece rack

**Figure 1 — Principle of a torsion apparatus**

**4.3 Test piece rack**, made of material of poor thermal conductivity, for holding the test piece in a vertical position in the heat transfer medium. The rack may be constructed to hold several test pieces. The rack is attached to a stand. It is advantageous to make the vertical portion of the stand from material of poor thermal conductivity. The base of the stand shall be of stainless steel or other corrosion-resistant material.

Two clamps shall be provided for holding each test piece. The bottom clamp shall be attached to the test piece rack. The top clamp acts as an extension of the test piece and is connected to the torsion wire by a rod.

**4.4 Heat-transfer medium**, liquid or gaseous, which remains fluid at the test temperature and which does not appreciably affect the material being tested, as prescribed in ISO 23529.

Gases may be employed as the heat transfer medium provided the design of the apparatus is such that results obtained using them duplicate those obtained with liquids.

NOTE The following fluids have been used satisfactorily:

- a) for temperatures down to  $-60\text{ }^{\circ}\text{C}$ , silicone fluids of kinematic viscosity of about  $5\text{ mm}^2/\text{s}$  at ambient temperature, which are usually suitable owing to their chemical inertness towards rubbers, their non-flammability and their non-toxicity;
- b) for temperatures down to  $-73\text{ }^{\circ}\text{C}$ , ethanol;
- c) for temperatures down to  $-120\text{ }^{\circ}\text{C}$ , methylcyclohexane cooled by liquid nitrogen (found to be satisfactory with the use of suitable apparatus).

**4.5 Temperature-measuring device**, capable of measuring temperature to within 0,5 °C over the whole range of temperature over which the apparatus is to be used.

The temperature sensor shall be positioned near the test pieces.

**4.6 Temperature control**, capable of maintaining the temperature of the heat-transfer medium to within  $\pm 1$  °C.

**4.7 Container for heat-transfer medium**, a bath for a liquid medium, or a test chamber for a gaseous medium, with means of heating the coolant.

**4.8 Stirrer**, for liquids, or **fan** or **blower**, for gases, which ensures thorough circulation of the heat-transfer medium. It is important that the stirrer also moves the liquid vertically to ensure a uniform temperature in the liquid.

**4.9 Stopwatch**, or other timing device, graduated in seconds.

## 5 Calibration

The requirements for calibration of the test apparatus are given in [Annex A](#).

## 6 Test piece

### 6.1 Preparation of test piece

Test pieces shall be prepared in accordance with ISO 23529.

The dimensions of the test piece shall be: length 40 mm  $\pm$  2,5 mm, width 3 mm  $\pm$  0,2 mm and thickness 2 mm  $\pm$  0,2 mm. It shall be moulded or cut with a suitable die from a moulded sheet of suitable thickness.

### 6.2 Conditioning of test piece

**6.2.1** The minimum time between forming and testing shall be 16 h.

For non-product tests, the maximum time between forming and testing shall be 4 weeks and, for evaluations intended to be comparable, the tests should be carried out, as far as possible, after the same time interval.

For product tests, whenever possible, the time between forming and testing should not exceed 3 months. In other cases, tests shall be made within 2 months of the date of receipt by the customer of the product.

**6.2.2** Samples and test pieces shall be protected from light as much as possible during the interval between forming and testing.

**6.2.3** Prepared test pieces shall be conditioned in accordance with ISO 23529 immediately before testing for a minimum of 3 h at a standard laboratory temperature, the same temperature being used throughout any one test or series of tests intended to be comparable.

## 7 Procedure

### 7.1 Mounting of test piece

Clamp each test piece used in such a manner that  $25 \text{ mm} \pm 3 \text{ mm}$  of the test piece is free between the clamps. The test piece clamp shall be located in such a position that the specimen is under zero torque or with a slight pre-load to keep the test piece straight when the temperature changes.

If the absolute modulus is required, measure the test length of the test pieces to the nearest 0,5 mm, the width to the nearest 0,1 mm and the thickness to the nearest 0,01 mm.

### 7.2 Stiffness measurements in liquid media

Make the reference measurement with the standard torsion wire (2,8 mN·m) at  $23 \text{ °C} \pm 2 \text{ °C}$ , either in air or in the liquid bath.

Place the rack containing the test pieces in the liquid bath with a minimum of 25 mm of liquid covering the test pieces.

Adjust the angle measuring device to zero. Then turn all test pieces at the same time, or in sequence, quickly but smoothly, through  $180^\circ$  and record the torsion angle after 10 s. If the test pieces are measured in sequence, ensure that all the measurements are completed within approximately 2 min. If the reading at  $23 \text{ °C}$  does not fall in the range of  $120^\circ$  to  $170^\circ$ , the standard torsion wire is not suitable for testing the test piece. Test pieces producing twists of more than  $170^\circ$  shall be tested with a wire having a torsional constant of 0,7 mN·m. Test pieces producing twists of less than  $120^\circ$  shall be tested with a wire having a torsional constant of 11,2 mN·m.

Remove the test pieces from the liquid bath (assuming the reference measurement has been made in liquid) and adjust the temperature of the liquid to the lowest temperature desired.

Place the test pieces in the bath with a minimum of 25 mm of liquid covering the test pieces and maintain them at this temperature for approximately 15 min.

Then increase the bath temperature by one of the two following methods:

- a) stepwise by  $5 \text{ °C}$  intervals, each increase being made after approximately 5 min;
- b) continuously with a heating rate of about  $1 \text{ °C/min}$ .

Make the stiffness measurements in the stepwise case after conditioning the test piece for 5 min at each temperature and in the continuous case at intervals of 1 min maximum. Continue the tests until a temperature is reached at which the angular twist is within  $5^\circ$  to  $10^\circ$  of the twist at  $23 \text{ °C}$ .

Record the angle of twist and the temperature at each measurement.

The relative modulus may be plotted on a graph during the test.

### 7.3 Stiffness measurements in gaseous media

#### 7.3.1 General

Procedures with air, carbon dioxide or nitrogen differ from those with liquid media only in that the cooling is done with the test pieces in the medium and the length of the conditioning period is different.

#### 7.3.2 Measurements

With the test pieces in the test chamber, adjust the temperature of the chamber to the lowest temperature desired in approximately 30 min. After this temperature has been maintained constant for 10 min, make the measurements in a similar way to those in the liquid media, ensuring that all the test pieces in the rack are tested within 2 min.



Then increase the chamber temperature by one of the two following methods:

- a) stepwise by 5 °C intervals, each increase being made after approximately 10 min;
- b) continuously with a heating rate of about 1 °C/min.

Make the stiffness measurements in the stepwise case after conditioning the test piece for 10 min at each temperature and, in the continuous case, at intervals of 1 min maximum. Continue the tests until a temperature is reached at which the angular twist is within 5° to 10° of the twist at 23 °C.

Record the angle of twist and the temperature at each measurement.

The relative modulus may be plotted on a graph during the test.

## 7.4 Crystallization

When it is desired to study crystallization or plasticizer effects, the time of conditioning at the desired temperature should be increased.

## 8 Number of tests

At least three test pieces of each material shall be tested. It is good practice to include a control rubber with known twist/temperature characteristics.

## 9 Expression of results

### 9.1 Torsional modulus

The torsional modulus of the test piece at any temperature is proportional to the quantity

$$\frac{180 - \alpha}{\alpha}$$

where  $\alpha$  is the angle of twist, in degrees, of the test piece.

### 9.2 Relative modulus

The relative modulus at any temperature is the ratio of the torsional modulus at that temperature to the torsional modulus at 23 °C.

The value of the relative modulus for any temperature is readily determined from the angles of twist at that temperature and at 23 °C, and the ratio of the values of the factor  $(180 - \alpha)/\alpha$  corresponding to those angles.

The temperatures at which the relative modulus is 2; 5; 10 and 100, respectively, are determined by the use of [Table 1](#) and the twist versus temperature values for the test piece. The first column of [Table 1](#) lists each degree of twist in the range of 120° to 170°, so that the value corresponding to the twist of the test piece at 23 °C can be selected.

Successive columns give the twist angles which correspond to values 2; 5; 10 and 100, respectively, for the relative modulus. The temperatures corresponding to these angles are designated as  $t_2$ ,  $t_5$ ,  $t_{10}$  and  $t_{100}$ , respectively.

### 9.3 Apparent torsional modulus of rigidity

When it is desired to calculate the apparent torsional modulus of rigidity in pascals at various temperatures, the free length of the test piece shall be accurately measured.

The apparent torsional modulus of rigidity,  $G$ , in pascals, is given by the equation

$$G = \frac{16KL(180 - \alpha)}{bd^3\mu\alpha}$$

where

$K$  is the torsional constant, in newton metres, of the torsion wire found at calibration;

$L$  is the measured free length, in metres, of the test piece;

$b$  is the width, in metres, of the test piece;

$d$  is the thickness, in metres, of the test piece;

$\mu$  is the factor based on the ratio  $b/d$  taken from [Table 2](#);

$\alpha$  is the angle of twist, in degrees, of the test piece.

## 10 Test report

The test report shall include the following information:

a) sample details:

- 1) a full description of the sample and its origin,
- 2) the method of preparation of the test piece from the sample, for example moulded or cut;

b) test method:

- 1) full reference to the test method used, i.e. the number of this International Standard,
- 2) the method used to increase the temperature of the test chamber;

c) test details:

- 1) the heat-transfer medium used,
- 2) the number of test pieces used;

d) test results:

- 1) the temperatures  $t_2$ ,  $t_5$ ,  $t_{10}$  and  $t_{100}$  at which the relative modulus was 2; 5; 10 and 100, respectively (individual test results plus mean results),
- 2) when required, the apparent torsional modulus of rigidity, in pascals, at standard laboratory temperature (individual test results plus mean results),
- 3) when required, the apparent torsional modulus at temperatures other than standard laboratory temperature (individual test results plus mean results),
- 4) when required, the temperature at which the apparent torsional modulus reached a specified value (individual test results plus mean result);
- 5) when required, a graph of the relative modulus versus temperature;

e) the date(s) of the test.

Table 1 — Twist angles for designated values of the relative modulus (RM)

Twist angle, $\alpha$ , in degrees at 23 °C	Twist angle, $\alpha$ , in degrees for relative modulus (RM)			
	RM = 2	RM = 5	RM = 10	RM = 100
120	90	51	30	3
121	91	52	31	4
122	92	53	31	4
123	93	54	32	4
124	95	55	33	4
125	96	56	33	4
126	97	57	34	4
127	98	58	35	4
128	99	59	36	4
129	101	61	36	5
130	102	62	37	5
131	103	63	38	5
132	104	64	39	5
133	105	65	40	5
134	107	66	41	5
135	108	68	42	5
136	109	69	42	5
137	111	70	43	6
138	112	71	45	6
139	113	72	46	6
140	114	74	47	6
141	116	75	48	6
142	117	77	49	7
143	119	78	50	7
144	120	80	51	7
145	121	82	53	7
146	123	83	54	7
147	124	85	55	7
148	126	87	57	8
149	127	88	58	8
150	129	90	60	9
151	130	92	62	9
152	132	94	62	9
153	133	96	65	10
154	134	97	67	10
155	136	100	69	11
156	138	102	71	11
157	139	104	73	12
158	140	106	75	12
159	142	108	78	13
160	144	111	80	13

Table 1 (continued)

Twist angle, $\alpha$ , in degrees at 23 °C	Twist angle, $\alpha$ , in degrees for relative modulus (RM)			
	RM = 2	RM = 5	RM = 10	RM = 100
161	146	113	82	14
162	147	116	85	15
163	149	118	88	16
164	151	121	91	17
165	152	124	94	18
166	154	126	98	19
167	156	130	101	20
168	158	133	105	22
169	159	136	109	24
170	161	139	113	26

Table 2 — Values<sup>a</sup> of factor  $\mu$  for various ratios of  $b/d$ 

$b/d$	$\mu$	$b/d$	$\mu$
1,00	2,25	2,25	3,84
1,05	2,36	2,50	3,99
1,10	2,46	2,75	4,11
1,15	2,56	3,00	4,21
1,20	2,66	3,50	4,37
1,25	2,75	4,00	4,49
1,30	2,83	4,50	4,59
1,35	2,91	5,00	4,66
1,40	2,99	6,00	4,77
1,45	3,06	7,00	4,85
1,50	3,13	8,00	4,91
1,60	3,26	9,00	4,96
1,70	3,38	10,00	5,00
1,75	3,43	20,00	5,17
1,80	3,48	50,00	5,23
1,90	3,57	100,00	5,30
2,00	3,66		

<sup>a</sup> Values of  $\mu$  have been rounded to two places of decimals.

## Annex A (normative)

### Calibration schedule

#### A.1 Inspection

Before any calibration is undertaken, the condition of the items to be calibrated shall be ascertained by inspection and recorded on a calibration report or certificate. It shall be reported whether calibration is carried out in the “as-received” condition or after rectification of any abnormality or fault.

It shall be ascertained that the apparatus is generally fit for the intended purpose, including any parameters specified as approximate and for which the apparatus does not therefore need to be formally calibrated. If such parameters are liable to change, then the need for periodic checks shall be written into the detailed calibration procedures.

#### A.2 Schedule

Verification/calibration of the test apparatus is a mandatory part of this International Standard. However, the frequency of calibration and the procedures used are, unless otherwise stated, at the discretion of the individual laboratory, using ISO 18899 for guidance.

The calibration schedule given in [Table A.1](#) has been compiled by listing all of the parameters specified in the test method, together with the specified requirement. A parameter and requirement can relate to the main test apparatus, to part of that apparatus, or to an ancillary apparatus necessary for the test.

For each parameter, a calibration procedure is indicated by reference to ISO 18899, to another publication or to a procedure particular to the test method which is detailed (whenever a calibration procedure which is more specific or detailed than that in ISO 18899 is available, it shall be used in preference).

The verification frequency for each parameter is given by a code-letter. The code-letters used in the calibration schedule are:

- C requirement to be confirmed but no measurement;
- N initial verification only;
- S standard interval as given in ISO 18899;
- U in use.

Table A.1 — Calibration schedule

Parameter	Requirement	Subclause in ISO 18899:2004	Verification frequency guide	Notes
Torsion head	Capable of rotating 180°	C	N	
Device for indication of angle	Friction-free Means of accurately setting zero	C C	N N	
Measurement of angle	±1°	15.9	S	
Base of stand	Corrosion-resistant material	C	N	
Nominal torsional constants of torsion wires	0,7 mN·m 2,8 mN·m 11,2 mN·m	P See Clause A.3	S	
Torsion wire length	65 ± 8 mm	15.2	S	
Test piece rack	Material of poor thermal conductivity	C	N	
Clamps	One connected to the rack, one not touching the rack	C	U	
Temperature-measuring device	±0,5 °C and near to the test pieces	18	S	
Bath or test chamber	To contain heat-transfer medium and maintain it at ± 1 °C	C	U	As shown by temperature indicator
Stirrer or fan	To ensure thorough circulation of medium, including vertical movement	C	N	
Stopwatch	±1 s	23.1	S	
Heat-transfer medium	See suitable examples in <a href="#">4.4</a>			

In addition to the items listed in [Table A.1](#), use of the following is implied, which need calibrating in accordance with ISO 18899:

- instruments for determining dimensions of the test pieces.

### A.3 Calibration of torsion wire

Insert one end of the torsion wire in a vertical position in the fixed clamp and attach the lower end of the wire at the exact midpoint of a uniform rod of known dimensions and mass. (It is suggested that the length of the rod be 200 mm to 250 mm and the diameter about 6,4 mm.)

Swing the rod through an angle of not more than 90° and then release it. Allow it to oscillate freely in a horizontal plane and note the time, in seconds, for 20 oscillations. (An oscillation includes the swing from one extreme to the other, and the return.)

The moment of inertia of the rod,  $I$ , expressed in kilogram metres squared, is given by the equation

$$I = \frac{mL^2}{12}$$

where

$m$  is the mass, in kilograms, of the rod;

$L$  is the length, in metres, of the rod.

The torsional constant of the wire (i.e. the restoring torque per radian),  $K$ , expressed in newton metres, is given by the equation

$$K = 4\pi^2 \frac{I}{T^2}$$

where  $T$  is the period, in seconds, of one oscillation.

The torsion wires shall calibrate to within  $\pm 5\%$  of their specified torsional constants.

## Bibliography

- [1] GEHMAN S.D., WOODFORD D.E., WILKINSON C.S. Low temperature characteristics of elastomers.  
*Ind. Eng. Chem.* 1947 Sept., **39** p. 1108





