**Glass in building — Determination of
the bending strength of glass —**

Part 5:
**Coaxial double ring test on flat
specimens with small test surface areas**

*Verre dans la construction — Détermination de la résistance du verre
à la flexion —*

*Partie 5: Essais avec doubles anneaux concentriques sur éprouvettes
planes, avec de petites surfaces de sollicitation*



COPYRIGHT PROTECTED DOCUMENT

© ISO 2016, Published in Switzerland

All rights reserved. Unless otherwise specified, no part of this publication may be reproduced or utilized otherwise in any form or by any means, electronic or mechanical, including photocopying, or posting on the internet or an intranet, without prior written permission. Permission can be requested from either ISO at the address below or ISO's member body in the country of the requester.

ISO copyright office
Ch. de Blandonnet 8 • CP 401
CH-1214 Vernier, Geneva, Switzerland
Tel. +41 22 749 01 11
Fax +41 22 749 09 47
copyright@iso.org
www.iso.org

Contents

Page

Foreword	iv
1 Scope	1
2 Normative references	1
3 Terms and definitions	1
4 Symbols	1
5 Principle of test method	2
6 Apparatus	3
6.1 Testing machine.....	3
6.2 Loading device.....	3
6.3 Measuring instruments.....	5
7 Sample	5
7.1 Shape and dimensions of specimens.....	5
7.2 Sampling and preparation of specimens.....	6
7.2.1 Cutting and handling.....	6
7.2.2 Conditioning.....	6
7.2.3 Examination.....	6
7.2.4 Adhesive film.....	6
7.3 Number of specimens.....	6
8 Procedure	6
8.1 Temperature.....	6
8.2 Humidity.....	6
8.3 Thickness measurement.....	6
8.4 Base plate.....	6
8.5 Positioning of specimen and loading ring.....	7
8.6 Load application.....	7
8.7 Location of the origin.....	7
8.8 Assessment of residual stresses.....	7
9 Evaluation	7
9.1 Limitation of the evaluation.....	7
9.2 Calculation of bending strength.....	8
10 Test report	8
Bibliography	9

Foreword

ISO (the International Organization for Standardization) is a worldwide federation of national standards bodies (ISO member bodies). The work of preparing International Standards is normally carried out through ISO technical committees. Each member body interested in a subject for which a technical committee has been established has the right to be represented on that committee. International organizations, governmental and non-governmental, in liaison with ISO, also take part in the work. ISO collaborates closely with the International Electrotechnical Commission (IEC) on all matters of electrotechnical standardization.

The procedures used to develop this document and those intended for its further maintenance are described in the ISO/IEC Directives, Part 1. In particular the different approval criteria needed for the different types of ISO documents should be noted. This document was drafted in accordance with the editorial rules of the ISO/IEC Directives, Part 2 (see www.iso.org/directives).

Attention is drawn to the possibility that some of the elements of this document may be the subject of patent rights. ISO shall not be held responsible for identifying any or all such patent rights. Details of any patent rights identified during the development of the document will be in the Introduction and/or on the ISO list of patent declarations received (see www.iso.org/patents).

Any trade name used in this document is information given for the convenience of users and does not constitute an endorsement.

For an explanation on the meaning of ISO specific terms and expressions related to conformity assessment, as well as information about ISO's adherence to the WTO principles in the Technical Barriers to Trade (TBT) see the following URL: [Foreword - Supplementary information](#)

The committee responsible for this document is ISO/TC 160, *Glass in building*, Subcommittee SC 2, *Use considerations* in conjunction with Technical Committee CEN/TC 129, *Glass in building*.

ISO 1288 consists of the following parts, under the general title *Glass in building — Determination of the bending strength of glass*:

- *Part 1: Fundamentals of testing glass*
- *Part 2: Coaxial double-ring test on flat specimens with large test surface areas*
- *Part 3: Test with specimen supported at two points (four-point bending)*
- *Part 4: Testing of channel-shaped glass*
- *Part 5: Coaxial double-ring test on flat specimens with small test surface areas*

This International Standard has been based on EN 1288-5, *Glass in building — Determination of the bending strength of glass — Part 5: Coaxial double-ring test on flat specimens with small test surface areas* prepared by Technical Committee CEN/TC 129 "Glass in building".

According to the CEN/CENELEC Internal Regulations, the national standards organizations of the following countries are bound to implement this European Standard: Austria, Belgium, Czech Republic, Denmark, Finland, France, Germany, Greece, Iceland, Ireland, Italy, Luxembourg, Netherlands, Norway, Portugal, Spain, Sweden, Switzerland and the United Kingdom.

Glass in building — Determination of the bending strength of glass —

Part 5:

Coaxial double ring test on flat specimens with small test surface areas

1 Scope

This part of ISO 1288 specifies a method for determining the comparative bending strength of glass for use in buildings, excluding the effects of the edges.

See ISO 1288-1, 5.1.4 for an explanation as to why this test method should only be used for comparing the strength of types of glass and not for assessing strength for design purposes.

The limitations of this part of ISO 1288 are described in ISO 1288-1.

ISO 1288-1 should be read in conjunction with this part of ISO 1288.

This test method is not suitable for patterned glass.

2 Normative references

The following documents, in whole or in part, are normatively referenced in this document and are indispensable for its application. For dated references, only the edition cited applies. For undated references, the latest edition of the referenced document (including any amendments) applies.

ISO 48, *Rubber, vulcanized or thermoplastic — Determination of hardness (hardness between 10 IRHD and 100 IRHD)*

3 Terms and definitions

For the purposes of this document, the following terms and definitions apply.

3.1

bending stress

tensile bending stress induced in the surface of a specimen

Note 1 to entry: For testing purposes, the bending stress should be uniform over a specified part of the surface.

4 Symbols

F	load	N
F_{\max}	load at breakage, “breaking load”	N
h	thickness of specimen	m
L	side length of square specimens	m
K_1, K_2	constants for calculation of bending stress	

r_1	radius of loading ring	m
r_2	radius of supporting ring	m
r_3	radius of circular specimens	m
r_{3m}	average specimen radius (for evaluation)	m
t	time	s
σ	stress	Pa
σ_{bB}	bending strength	Pa
μ	Poisson number of specimen	
	NOTE for soda lime silicate glass (see ISO 16293-1), a value of 0,23 is used.	
$\Delta F/\Delta t$	rate of increase of load	N/s
$\Delta\sigma/\Delta t$	rate of increase of stress	Pa/s

5 Principle of test method

A circular or square plane-parallel specimen with radius r_3 , or length of side L , resting on a supporting ring (radius r_2) shall be loaded by means of a loading ring (radius r_1) arranged concentrically relative to the supporting ring (see [Figure 1](#)).

Outside the loading ring, the radial and tangential stresses in the specimen decrease towards the edge so that the risk of failure there is small.

For limited loads, F , (depending on the values of r_1 , r_2 , r_3 and h) there is, in the central region of the convexly bent specimen surface, a tensile stress field (see Reference [3]) extending in all directions and uniform, the area in this field being bounded by the loading ring.

By increasing the load, F , the tensile stress in the middle of the specimen is increased at a constant rate until failure occurs, the expected point of failure being in the most severely stressed surface region defined by the loading ring.

The bending strength, σ_{bB} , shall be calculated from the maximum load, F_{max} , measured when failure occurs and the specimen thickness, h , taking into account the dimensions of the square or circular specimens and the value for Poisson number, μ , of the specimen.

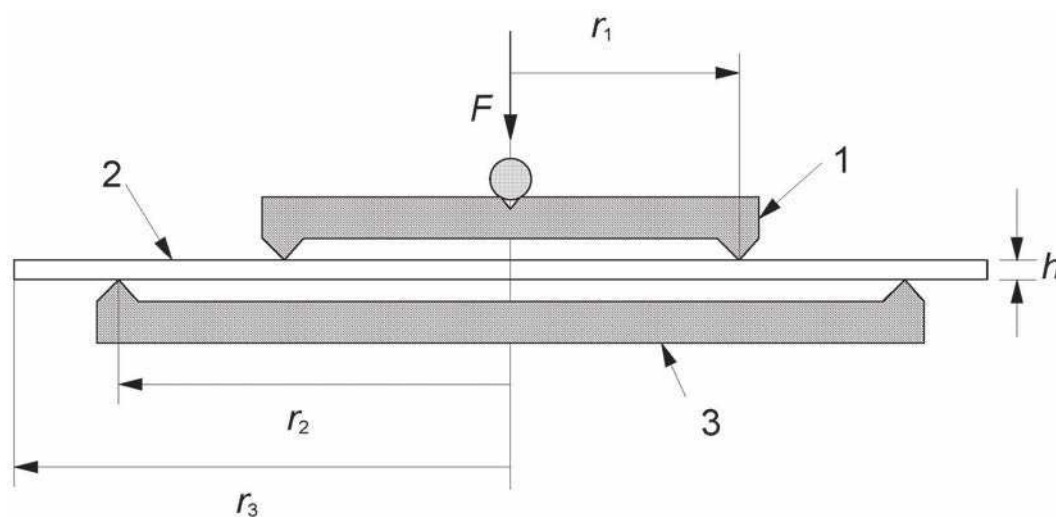

Key

- 1 loading ring
- 2 specimen
- 3 supporting ring

Figure 1 — Test arrangement (indicating the principle), illustrated for a circular specimen

6 Apparatus

6.1 Testing machine

The bending test shall be carried out using a suitable bending testing machine, which shall incorporate the following features.

- a) The stressing of the specimen shall be capable of being applied from zero up to a maximum value in a manner which minimizes shock and is stepless.
- b) The stressing device shall be capable of the specified rate of stressing.
- c) The testing machine shall incorporate a load measuring device with a limit of error of $\pm 2,0\%$ within the measuring range.

6.2 Loading device

The loading device shall be arranged as illustrated in [Figure 2](#), with dimensions conforming to [Table 1](#) for the two combinations of loading ring and supporting ring accepted for the coaxial double-ring bending test.

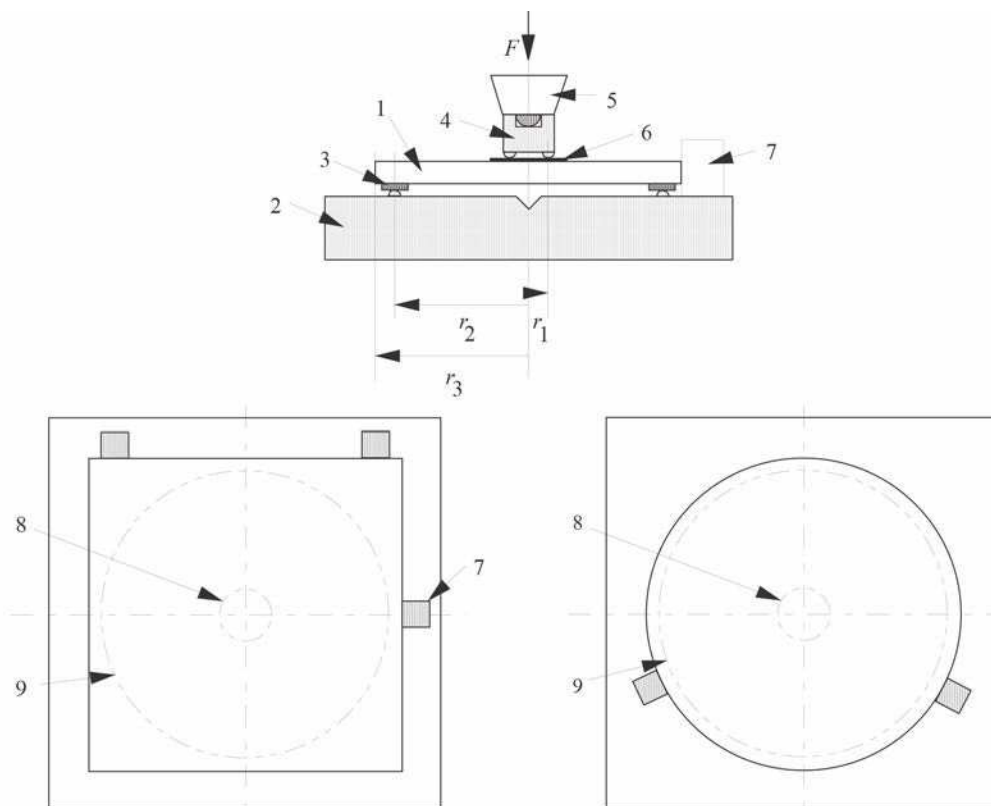

Key

- 1 specimen
- 2 base plate of hardened steel provided with a supporting ring
- 3 spacer of silicone rubber
- 4 loading ring of hardened steel
- 5 load transmitting member with a centring feature for the loading ring
- 6 spacer of paper or synthetic material approximately 0,1 mm thick
- 7 adjusting jaw for centring the specimen
- 8 contact circle of loading ring
- 9 contact circle of supporting ring

Figure 2 — Loading device

Table 1 — Dimensions of loading ring and supporting ring

Dimensions in millimetres

Loading device	Radius of loading ring r_1	Radius of supporting ring r_2	Radius r_3 or $L/2$ of specimen as specified in Table 2
R30	6	30	33
R45	9	45	50
R60	20	60	120
R105	35	105	210

The radius of curvature of the bearing surface of the supporting ring shall be 2,5 mm.

The silicone rubber shall be 3 mm thick, or alternatively a rubber section, 3 mm thick, matched to the supporting ring with a hardness of (40 ± 10) IRHD (according to ISO 48).

The radius of curvature of the bearing surface of the loading ring shall be 2,5 mm.

6.3 Measuring instruments

The following measuring instruments are required:

- a measuring instrument enabling the diameter or the length of the side of the specimen to be measured to the nearest 1 mm;
- a measuring instrument allowing the thickness of the specimen to be measured to the nearest 0,01 mm.

7 Sample

7.1 Shape and dimensions of specimens

Circular or square specimens as specified in [Table 2](#) and [Table 3](#) shall be used.

Table 2 — Dimensions of specimens

Dimensions in millimetres

Loading device	Diameter (= $2r_3$) or side length L	Thickness h	
		minimum	maximum
R30	66 ± 2	see Table 3	6
R45	100 ± 2	see Table 3	9
R60	240 ± 5	see Table 3	12
R105	420 ± 5	see Table 3	19

Table 3 — Minimum thickness of specimens as a function of bending strength

Dimensions in millimetres

Bending strength σ_{bB} MPa	Minimum thickness of specimens for loading device			
	R45	R30	R60	R105
$\sigma_{bB} \leq 100$	2,0	1,0	2,5	4,5
$100 < \sigma_{bB} \leq 200$	2,5	1,5	3,5	6,0
$200 < \sigma_{bB} \leq 300$	3,0	2,0	4,5	7,5
$300 < \sigma_{bB} \leq 400$	3,5	2,5	5,0	8,5
$400 < \sigma_{bB} \leq 500$	3,5	2,5	5,5	9,5
$500 < \sigma_{bB} \leq 600$	4,0	3,0	6,0	10,5

In cases in which not even the approximate value of the anticipated bending strength is known beforehand, the data given in the last line of [Table 3](#) (values for bending strength up to 600 MPa) shall be taken for the minimum thickness of the specimens. After the first tests have been evaluated, the appropriate minimum thickness shall be determined from [Table 3](#).

The following tolerances shall apply to that portion of the specimen bounded by the contact circle of the supporting ring:

- the flatness tolerance shall be 0,1 mm;
- the parallelism tolerance shall be 2 % of the specimen thickness.

7.2 Sampling and preparation of specimens

7.2.1 Cutting and handling

The greatest care shall be taken that the test surface, which will be subsequently subjected to tensile stress, does not come into contact with tools, grinding agents, glass splinters, etc. and also is not damaged during storage.

NOTE 1 In order to preserve specific surface conditions, the test surface can be provided with a protective coating (glued down) during specimen preparation.

NOTE 2 The method of cutting specimens is not significant and no edge processing is necessary.

7.2.2 Conditioning

Protective coatings shall be removed 24 h before the test (see ISO 1288-1). The specimen shall be stored in the test environment (see [8.1](#) and [8.2](#)) for at least 4 h before testing.

7.2.3 Examination

Before the bending strength test, all specimens shall be examined over the test surface area for any faults which are not representative of the quality characteristics of the material tested.

7.2.4 Adhesive film

To hold together the fragments, an adhesive film shall be fixed to the side of the specimen facing the loading ring. This facilitates location of the fracture origin and measurement of the specimen thickness.

7.3 Number of specimens

The number of specimens to be tested shall be determined depending on the confidence limits required, especially with regard to estimating the extremes of the strength distribution (see ISO 1288-1 for a discussion of numbers of specimens).

8 Procedure

8.1 Temperature

The coaxial ring bending test shall be carried out at a temperature of (23 ± 5) °C. During the test, the temperature of the specimen shall be kept constant to 1 °C in order to avoid the development of thermal stresses.

8.2 Humidity

The coaxial ring bending test shall be carried out at a relative humidity between 40 % and 70 %.

8.3 Thickness measurement

To prevent damage from being caused to the surface by measuring instruments, the thickness shall be measured at four points on the edge of the specimen. The average shall be taken from these measured values.

8.4 Base plate

The base plate is centred by moving down the force transmitting component (without the loading ring and specimen) into the adjusting cone (see [Figure 2](#)). The base plate shall be locked in this position.

Glass splinters and other hard and sharp-edged particles shall be cleaned from the supporting ring. Damage to the supporting ring shall be eliminated.

8.5 Positioning of specimen and loading ring

The silicone rubber spacer shall be positioned between the specimen and the base plate in such a way that, at each point, it protrudes beyond the bearing annulus on each side by not less than 5 mm. The specimen shall be placed in position with the surface to be tested downwards. The loading ring, which has been cleaned to remove splinters, shall then be lowered onto the top side of the specimen and centred, with the paper or synthetic spacer placed between the loading ring and the specimen (see [Figure 2](#)).

8.6 Load application

The test load, F , shall be increased in such a way that the bending stress in the middle of the specimen rises at a rate of $(2 \pm 0,4)$ MPa/s until failure of the specimen occurs.

For calculating the rate of increase of the bending stress, Formula (1) shall be used for circular specimens and Formula (2) for square specimens:

$$\frac{\Delta\sigma}{\Delta t} = \frac{K_1}{h^2} \cdot \frac{\Delta F}{\Delta t} \quad (1)$$

$$\frac{\Delta\sigma}{\Delta t} = \frac{K_2}{h^2} \cdot \frac{\Delta F}{\Delta t} \quad (2)$$

NOTE The values of K_1 and K_2 depend on the Poisson number of the specimen. For soda lime silicate glass, the value of K_1 is 1,09 and the value of K_2 is 1,04 (see ISO 1288-1) for both the R30 and the R45 rings while the value of K_1 is 0,686 and the value of K_2 is 0,674 for both the R60 and the R105 rings.

The maximum load, F_{\max} , shall be read from the load measuring device of the testing machine.

8.7 Location of the origin

The location of the origin of the fracture^[4] shall be determined from the fragments. The position of the origin of the fracture “inside or outside the contact circle of the loading ring” shall be determined for every specimen.

NOTE After fracture, further thickness measurements, for control purposes, can be made on fragments from the centre of the specimen bounded by the loading ring contact circle, preferably as close to the fracture origin as possible.

8.8 Assessment of residual stresses

If the specimens are considered to be free from inherent stresses, (that is, they are of annealed glass), this condition shall be examined photo-elastically, in the case of transparent glasses, on specimens or suitable fragments. Stress-free specimens placed between cross-polarized polarizing filters shall not show any significant brightness variations when viewed through the cross-section over an optical path length of 5 mm.

9 Evaluation

9.1 Limitation of the evaluation

For evaluation purposes, only those specimens shall be considered in which the origin of the fracture lies within the area defined by the loading ring.

9.2 Calculation of bending strength

The bending strength, σ_{bB} associated with the maximum load F_{max} shall be calculated from Formula (3) for circular specimens and from Formula (4) for square specimens.

$$\sigma_{bB} = K_1 \frac{F_{max}}{h^2} \quad (3)$$

$$\sigma_{bB} = K_2 \frac{F_{max}}{h^2} \quad (4)$$

10 Test report

The test report shall include the following information, with reference to this part of ISO 1288:

- a) type and name of glass;
- b) pre-treatment and condition of specimen surface including the sequence of treatment stages performed;
- c) inherent stress of the specimen, annealed or prestressed glass, including nature and, if possible, degree of prestressing;
- d) shape of specimens (circular or square);
- e) type of loading device (R45 or R30);
- f) number of specimens;
- g) for each specimen, the following information:
 - 1) specimen thickness, h , in mm to the nearest 0,05 mm;
 - 2) bending strength, σ_{bB} , in MPa, rounded to the nearest 0,1 MPa, of each specimen broken in accordance with [9.1](#);
 - 3) time to breakage in seconds to the nearest 1 s.No average for the measured results shall be given;
- h) number of specimens not broken in accordance with [9.1](#);
- i) any deviation from this part of ISO 1288 which may have affected the results.

Bibliography

- [1] ISO 1288-1, *Glass in building — Determination of the bending strength of glass — Part 1: Fundamentals of testing glass*
- [2] ISO 16293-1, *Glass in building — Basic soda lime silicate glass products — Part 1: Definitions and general physical and mechanical properties*
- [3] SCHMITT R.W., BLANK K., SCHÖNBRUNN G. *Experimentelle Spannungsanalyse zum Doppelringverfahren (Experimental stress analysis for the double ring method)*; Sprechsaal 116 (1983), No.5, pp.397-405 and printing error correction in Sprechsaal 116 (1983),No.8, p669
- [4] KERKHOF F. *Bruchvorgänge in Gläsern. (Fracture Processes in Glass.)*; Deutsche Glastechnische Gesellschaft, Frankfurt/Main 1970, p. 209 ff

