**Plastics — Poly(vinyl chloride) resins —
Determination of number of impurities
and foreign particles**

*Plastiques — Résines de poly(chlorure de vinyle) — Détermination du
nombre d'impuretés et de corps étrangers*



PDF disclaimer

This PDF file may contain embedded typefaces. In accordance with Adobe's licensing policy, this file may be printed or viewed but shall not be edited unless the typefaces which are embedded are licensed to and installed on the computer performing the editing. In downloading this file, parties accept therein the responsibility of not infringing Adobe's licensing policy. The ISO Central Secretariat accepts no liability in this area.

Adobe is a trademark of Adobe Systems Incorporated.

Details of the software products used to create this PDF file can be found in the General Info relative to the file; the PDF-creation parameters were optimized for printing. Every care has been taken to ensure that the file is suitable for use by ISO member bodies. In the unlikely event that a problem relating to it is found, please inform the Central Secretariat at the address given below.

© ISO 2007

All rights reserved. Unless otherwise specified, no part of this publication may be reproduced or utilized in any form or by any means, electronic or mechanical, including photocopying and microfilm, without permission in writing from either ISO at the address below or ISO's member body in the country of the requester.

ISO copyright office
Case postale 56 • CH-1211 Geneva 20
Tel. + 41 22 749 01 11
Fax + 41 22 749 09 47
E-mail copyright@iso.org
Web www.iso.org

Published in Switzerland

Foreword

ISO (the International Organization for Standardization) is a worldwide federation of national standards bodies (ISO member bodies). The work of preparing International Standards is normally carried out through ISO technical committees. Each member body interested in a subject for which a technical committee has been established has the right to be represented on that committee. International organizations, governmental and non-governmental, in liaison with ISO, also take part in the work. ISO collaborates closely with the International Electrotechnical Commission (IEC) on all matters of electrotechnical standardization.

International Standards are drafted in accordance with the rules given in the ISO/IEC Directives, Part 2.

The main task of technical committees is to prepare International Standards. Draft International Standards adopted by the technical committees are circulated to the member bodies for voting. Publication as an International Standard requires approval by at least 75 % of the member bodies casting a vote.

Attention is drawn to the possibility that some of the elements of this document may be the subject of patent rights. ISO shall not be held responsible for identifying any or all such patent rights.

ISO 1265 was prepared by Technical Committee ISO/TC 61, *Plastics*, Subcommittee SC 9, *Thermoplastic materials*.

This second edition cancels and replaces the first edition (ISO 1265:1979), which has been technically revised.

Introduction

Poly(vinyl chloride) resins are commonly produced as various powders that are essentially white in colour. However, the polymerization of vinyl chloride monomer into poly(vinyl chloride) uses processes that may cause some particulate impurities to be included in the powders because of the design of the construction plant and the use of heat.

This International Standard describes a simple procedure for determining the number of impurities and foreign particles in a sample, with clarification of the different cases encountered (highly contaminated, heterogeneous or homogeneous contamination of the sample).

Plastics — Poly(vinyl chloride) resins — Determination of number of impurities and foreign particles

1 Scope

This International Standard specifies a method for determining the number of impurities and foreign particles in a flattened surface of poly(vinyl chloride) resin. It is not applicable to paste resins because of their finely divided state.

2 Principle

A certain quantity of resin is flattened between a rigid plate (covered with a sheet of glazed white paper) and a glass plate containing a grid, and the number of specks (impurities and foreign particles) of size greater than 0,250 mm, i.e. clearly visible to the naked eye, is counted in 25 squares of the grid.

The result is expressed, by extrapolation, as the number of specks per 100 squares of the grid.

3 Apparatus

3.1 Glass plate, 340 mm × 340 mm × 4,5 mm, colourless, perfectly transparent, and without defects such as stripes, bubbles or black spots.¹⁾

Mark in the centre of the surface of the glass sheet a grid measuring 300 mm × 300 mm, consisting of 100 30 mm × 30 mm squares. This grid may be drawn with an indelible pencil, a diamond or any other appropriate tool, on the face of the sheet which is not in contact with the resin.

3.2 Rigid plate, 450 mm × 450 mm, covered with a sheet of glazed white paper.

3.3 Timer (e.g. stopwatch).

4 Procedure

Spread out about 200 cm³ of the test sample on the rigid plate (3.2).

Place the glass plate (3.1) on the test sample and, by slight movements of the plate, spread the sample so that it touches the glass over an area of at least 25 squares, preferably in the centre of the plate.

Mark the limits of the entire 25 selected squares with a thick pencil mark (see Figure 1).

Count the number, n_1 , of coloured and black “specks” (impurities and foreign particles) visible to the naked eye inside the selected squares, within a period of 2 min. The selected squares shall be viewed from a distance of about 300 mm in good laboratory lighting conditions.

1) If there are any defects in the glass plate, take this into account in the determination.

NOTE 1 2 min is the maximum time before the operator's eyes become tired.

NOTE 2 A photographic reference scale is provided to indicate which particles are to be counted (see Figure 2).

Repeat the counting process (giving counts of n_2, n_3, n_4) as necessary, using a new test sample each time, according to the following schedule:

a) First determination (count n_1)

- If there are too many specks inside the 25 squares to count within 2 min, the number of squares examined, S , shall be noted in addition to the number of specks counted, n_1 , and no further samples shall be tested.
- If it is possible to count all the specks in the 25 squares within 2 min, carry out a second determination on a fresh test sample.

b) Second determination (count n_2)

- If, in the second determination, there are too many specks inside the 25 squares to count within 2 min, the number of squares examined, S , shall be noted in addition to the number of specks counted, n_2 , and no further samples shall be tested.
- If $|n_1 - n_2| < 3$, the contamination is considered to be homogeneous and no further samples shall be tested.
- If $|n_1 - n_2| \geq 3$, the contamination is considered to be heterogeneous and a third determination shall be carried out on a fresh test sample.

c) Third determination (count n_3)

- If, in the third determination, there are too many specks inside the 25 squares to count within 2 min, the number of squares examined, S , shall be noted in addition to the number of specks counted, n_3 , and no further samples shall be tested.
- If it is possible to count all the specks in the 25 squares within 2 min, carry out a fourth determination on a fresh test sample.

d) Fourth determination (count n_4)

- If, in the fourth determination, there are too many specks inside the 25 squares to count within 2 min, the number of squares examined, S , shall be noted in addition to the number of specks counted, n_4 .

A flow diagram showing the above procedure is included as Annex A.

5 Expression of results

The number of specks per 100 squares, P , shall be expressed in accordance with the experimental schedule described in Clause 4 (see also Annex A).

- If, in any of the determinations, there were too many specks inside the 25 squares to count within 2 min, the resin is highly contaminated and the number of specks per 100 squares, P , shall be calculated from the equation:

$$P = (n \times 100)/S$$

where

$$n = n_1, n_2, n_3 \text{ or } n_4;$$

S is the number of squares examined.

- If two determinations were made and $|n_1 - n_2| < 3$, the contamination of the resin is homogeneous and the number of specks per 100 squares, P , shall be calculated from the equation:

$$P = 2(n_1 + n_2)$$

- If four determinations were made, the contamination of the resin is heterogeneous and the number of specks per 100 squares, P , shall be calculated from the equation:

$$P = n_1 + n_2 + n_3 + n_4$$

6 Test report

The test report shall include the following information:

- a) all details necessary for complete identification of the product tested;
- b) a reference to this International Standard;
- c) the result, expressed in accordance with Clause 5;
- d) any unusual features noted during the determination;
- e) the date of the test.

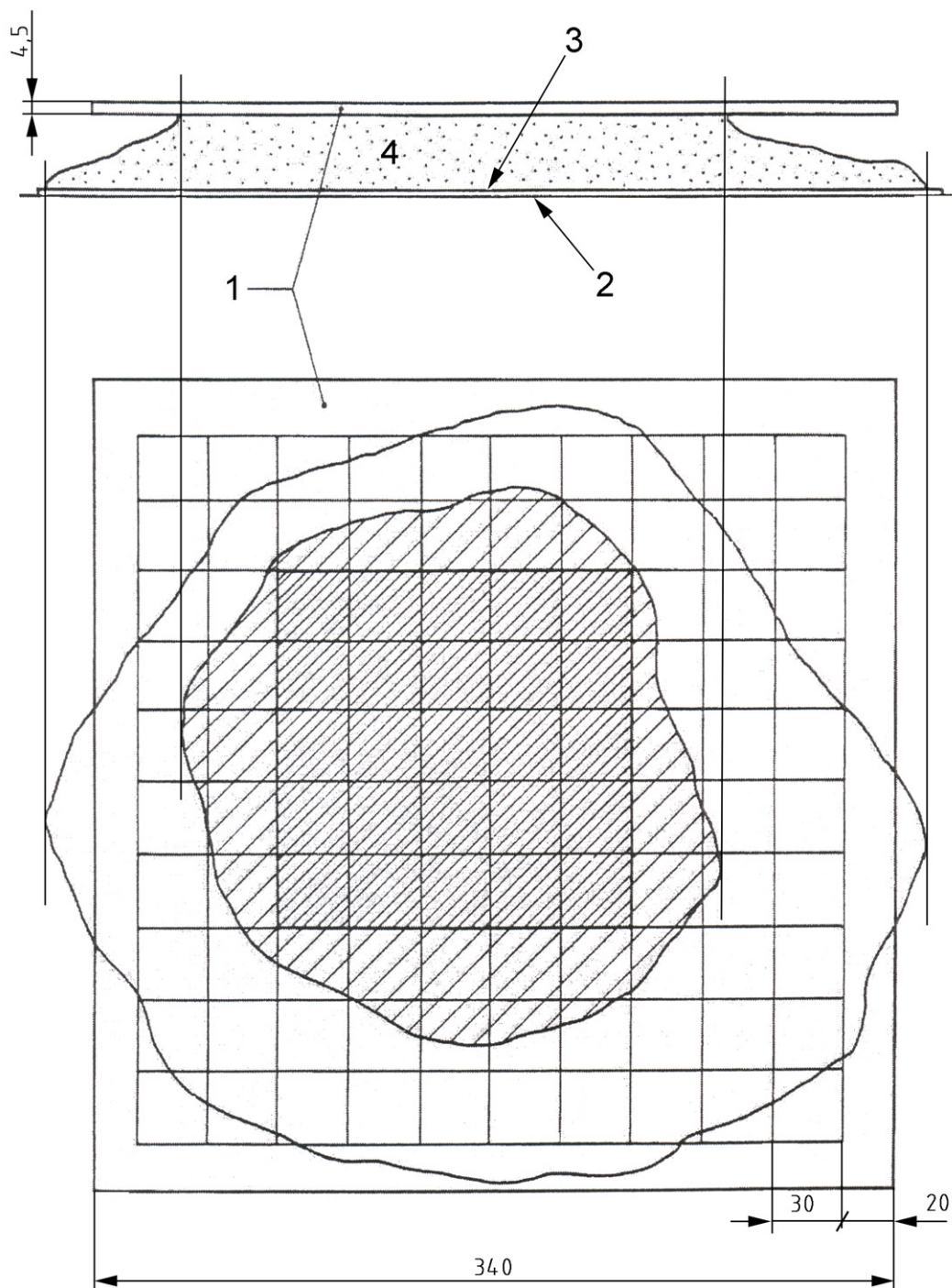

Key

- 1 glass sheet
- 2 rigid plate
- 3 sheet of glazed white paper
- 4 resin

Broad hatching: area of contact between glass plate and resin.

Close hatching: group of 25 squares chosen for the count.

Figure 1 — Method of spreading the resin on the glass plate to count the impurities and foreign particles

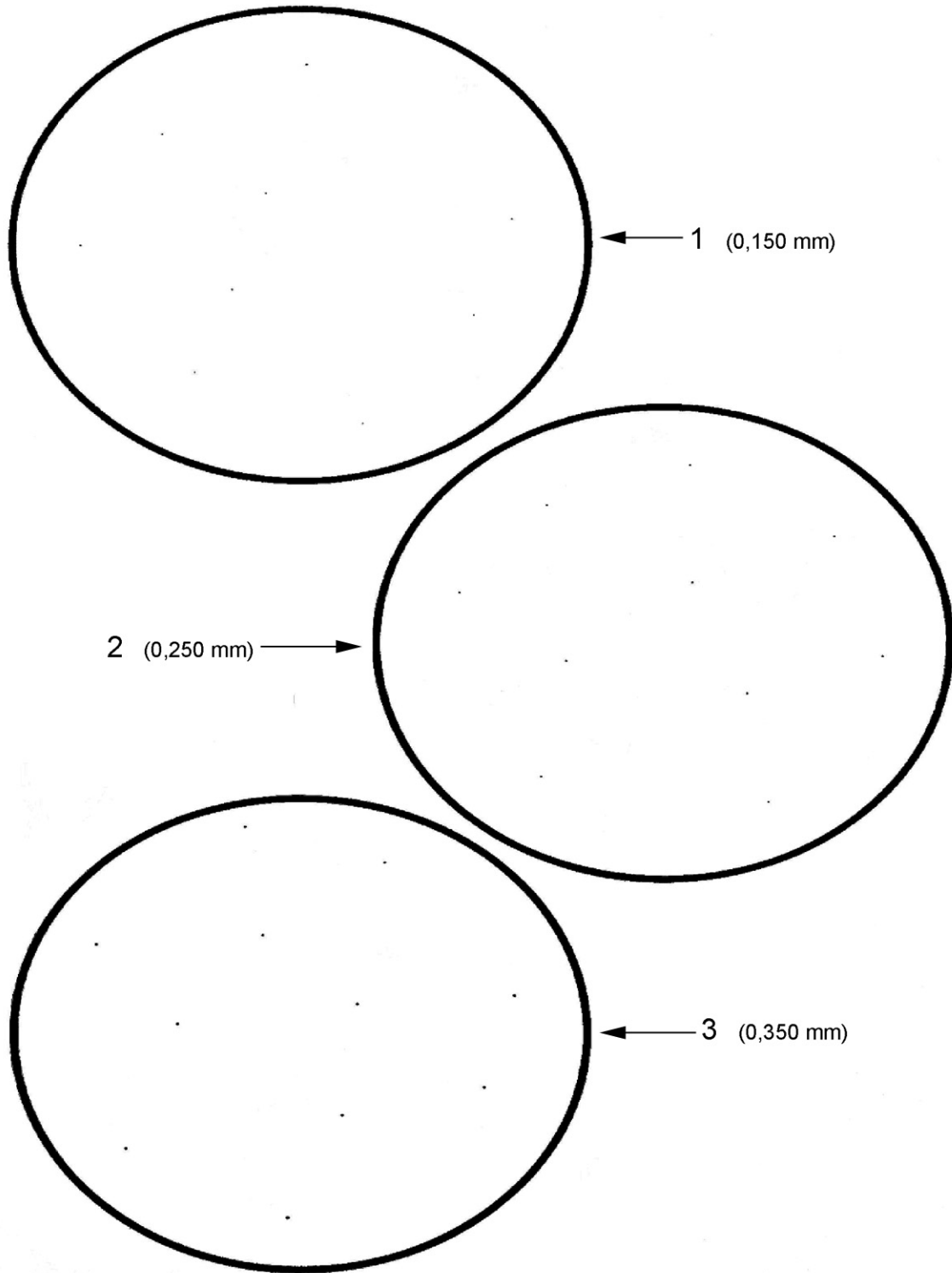

Figure 2 — Photographic reference scale

Annex A
(informative)

Flow diagram for counting the number of specks (impurities and foreign particles) and expression of results

