

# INTERNATIONAL STANDARD

**ISO**  
**1210**

Second edition  
1992-08-01

---

---

## **Plastics — Determination of the burning behaviour of horizontal and vertical specimens in contact with a small-flame ignition source**

*Plastiques — Détermination du comportement au feu d'éprouvettes  
horizontales et verticales au contact d'une petite flamme comme source  
d'allumage*



Reference number  
ISO 1210:1992(E)

## Foreword

ISO (the International Organization for Standardization) is a worldwide federation of national standards bodies (ISO member bodies). The work of preparing International Standards is normally carried out through ISO technical committees. Each member body interested in a subject for which a technical committee has been established has the right to be represented on that committee. International organizations, governmental and non-governmental, in liaison with ISO, also take part in the work. ISO collaborates closely with the International Electrotechnical Commission (IEC) on all matters of electrotechnical standardization.

Draft International Standards adopted by the technical committees are circulated to the member bodies for voting. Publication as an International Standard requires approval by at least 75 % of the member bodies casting a vote.

International Standard ISO 1210 was prepared by Technical Committee ISO/TC 61, *Plastics*, Sub-Committee SC 4, *Burning behaviour*.

This second edition cancels and replaces the first edition (ISO 1210:1982), of which it constitutes a technical revision.

Annex A of this International Standard is for information only.

© ISO 1992

All rights reserved. No part of this publication may be reproduced or utilized in any form or by any means, electronic or mechanical, including photocopying and microfilm, without permission in writing from the publisher.

International Organization for Standardization  
Case Postale 56 • CH-1211 Genève 20 • Switzerland

Printed in Switzerland

# Plastics — Determination of the burning behaviour of horizontal and vertical specimens in contact with a small-flame ignition source

## 1 Scope

1.1 This International Standard specifies a small-scale laboratory screening procedure for comparing the relative burning behaviour of vertically or horizontally oriented plastic specimens exposed to a small-flame ignition source.

1.2 This method of test determines the afterflame/afterglow times and damaged length of specimens. It is applicable to solid and cellular materials having an apparent density of not less than  $250 \text{ kg/m}^3$ , determined in accordance with ISO 845. This method is not applicable to materials that shrink away from the applied flame without igniting.

1.3 The classification system described in annex A is intended for quality assurance and the preselection of component materials for products.

This system is not intended for assessment of the fire behaviour of building materials or furnishings. The method of test described may be used for the preselection acceptance of a material, providing positive results are obtained at the thickness equal to the smallest thickness used in the application.

NOTE 1 Test results are influenced by material components, e.g. pigments, fillers and fire-retardants, and properties such as the direction of anisotropy and molecular mass.

## 2 Normative references

The following standards contain provisions which, through reference in this text, constitute provisions of this International Standard. At the time of publication, the editions indicated were valid. All standards are subject to revision, and parties to agreements based on this International Standard

are encouraged to investigate the possibility of applying the most recent editions of the standards indicated below. Members of IEC and ISO maintain registers of currently valid International Standards.

ISO 291:1977, *Plastics — Standard atmospheres for conditioning and testing*.

ISO 293:1986, *Plastics — Compression moulding test specimens of thermoplastic materials*.

ISO 294:1975, *Plastics — Injection moulding test specimens of thermoplastic materials*.

ISO 295:1991, *Plastics — Compression moulding of test specimens of thermosetting materials*.

ISO 845:1988, *Cellular plastics and rubbers — Determination of apparent (bulk) density*.

ISO 1043-1:1987, *Plastics — Symbols — Part 1: Basic polymers and their special characteristics*.

ISO 5725:1986, *Precision of test methods — Determination of repeatability and reproducibility for a standard test method by inter-laboratory tests*.

ISO 10093:—<sup>1)</sup>, *Plastics — Fire tests — Standard ignition sources*.

## 3 Definitions

For the purposes of this International Standard, the following definitions apply.

**3.1 afterflame:** Persistence of flaming of a material, under specified test conditions, after the ignition source has been removed.

**3.2 afterflame time:** The length of time for which a material continues to flame, under specified test

1) To be published.

conditions, after the ignition source has been removed.

**3.3 afterglow:** Persistence of glowing of a material, under specified test conditions, after cessation of flaming or, if no flaming occurs, after removal of the ignition source.

**3.4 afterglow time:** The time during which a material continues to glow, under specified test conditions, after cessation of flaming or after the ignition source has been removed.

## 4 Principle

A test specimen bar is supported horizontally or vertically by one end and the free end is exposed to a specified gas flame. The burning behaviour of the bar is assessed by measuring the linear burning rate (method A) or the afterflame/afterglow times (method B).

## 5 Significance of test

**5.1** Tests made on a material under the conditions specified can be of considerable value in comparing the relative burning behaviour of different materials, in controlling manufacturing processes, or in assessing any change in burning characteristics prior to, or during use. The results obtained from this method are dependent on the shape, orientation and environment surrounding the specimen and on the conditions of ignition. Correlation with performance under actual service conditions is not implied.

**5.2** Results obtained in accordance with this International Standard shall not be used to describe or appraise the fire hazard presented by a particular material or shape under actual fire conditions. Assessment for fire hazard requires consideration of such factors as: fuel contribution, intensity of burning (rate of heat release), products of combustion and environmental factors such as the intensity of source, orientation of exposed material and ventilation conditions.

**5.3** Burning behaviour as measured by this test method is affected by such factors as density, any anisotropy of the material and the thickness of the specimen.

**5.4** Certain materials may shrink from the applied flame without igniting. In this event, test results are not valid and additional test specimens will be required to obtain valid tests. If the test specimens continue to shrink from the applied flame without igniting, these materials are not suitable for evaluation by this method of test.

**5.5** The burning behaviour of some plastic materials may change with time. It is accordingly advisable to make tests before and after ageing by an appropriate procedure. The preferred oven conditioning shall be 7 days at 70 °C. However, other ageing times and temperatures may be used by agreement between the interested parties and shall be noted in the test report.

**5.6** The effect on the burning behaviour of additives, deterioration, and possible loss of volatile components are measurable using this method. Results obtained using this method may serve for comparing the relative performance of materials and can be helpful in material assessment.

## 6 Apparatus

**6.1 Laboratory fume hood/cupboard,** having an inside volume of at least 0,5 m<sup>3</sup>. The chamber shall permit observation and shall be draught-free, while permitting normal thermal circulation of air past the specimen during burning. For safety and convenience, it is desirable that this enclosure (which can be completely closed) be fitted with an evacuation device, such as an exhaust fan, to remove products of combustion, which may be toxic. However, it is important to be able to turn the device off during the actual test and start it again immediately after the test to remove the products of combustion.

NOTE 2 The amount of oxygen available to support combustion is naturally important for the conduct of these flame tests. For tests conducted by this method when burning times are protracted, chamber sizes less than 1 m<sup>3</sup> may not provide accurate results.

**6.2 Laboratory burner,** as specified in ISO 10093, (ignition source P/PF2), having a barrel length of 100 mm ± 10 mm and an internal diameter of 9,5 mm ± 0,3 mm. Do not equip the barrel with an end attachment such as a stabilizer.

**6.3 Ring stand,** with clamps or the equivalent, adjustable for positioning of the specimen.

**6.4 Timing device,** accurate to 1 s.

**6.5 Measuring scale,** graduated in millimetres.

**6.6 Supply of technical-grade methane gas,** with regulator and meter for uniform gas flow.

NOTE 3 Other gas mixtures having a heat content of approximately 37 MJ/m<sup>3</sup> have been found to provide similar results.

**6.7 Desiccator,** containing anhydrous calcium chloride or other drying agent.

**6.8 Conditioning room or chamber**, capable of being maintained at  $23\text{ °C} \pm 2\text{ °C}$  and a relative humidity of  $(50 \pm 5)\%$ .

**6.9 Micrometer**, capable of being read to 0,01 mm.

**6.10 Air-circulating oven**, capable of being maintained at  $70\text{ °C} \pm 1\text{ °C}$  while providing not less than five air changes per hour.

## 7 Specimens

**7.1** All specimens shall be cut from a representative sample of the material (sheets or end-products), or shall be cast or injection- (see ISO 294), compression- (see ISO 293 or ISO 295) or transfer-moulded to the necessary shape. After any cutting operation, care shall be taken to remove all dust and any particles from the surface; cut edges shall have a smooth finish.

**7.2** Bar specimens should preferably be  $125\text{ mm} \pm 5\text{ mm}$  long,  $13,0\text{ mm} \pm 0,3\text{ mm}$  wide and  $3,0\text{ mm} \pm 0,2\text{ mm}$  thick.

Other thicknesses may be used by agreement between the interested parties and, if so, shall be noted in the test report. However, the maximum thickness shall not exceed 13 mm.

**NOTE 4** Tests made on specimens of different thicknesses, densities, molecular masses, directions of anisotropy and types or levels of colour(s) or filler(s) and flame-retardant(s) may not be comparable.

**7.3** A minimum of 26 bar specimens shall be prepared.

**NOTE 5** It is advisable to prepare additional specimens in the event that the situation described in 5.4 is encountered.

## 8 Method A — Determination of linear burning rate of horizontal specimens

**8.1 Complementary apparatus** (see figure 1)

**8.1.1 Wire gauze**, 20 mesh (approximately 20 openings per 25 mm), made with 0,40 mm to 0,45 mm diameter steel wire and cut into 125-mm squares.

**8.1.2 Support fixture**, for testing specimens that are not self-supporting (see figure 2).

### 8.2 Specimens

Three specimens shall be tested. Each specimen shall be marked with two lines perpendicular to the longitudinal axis of the bar, 25 mm and 100 mm from the end that is to be ignited.

Dimensions in millimetres,  
unless stated otherwise

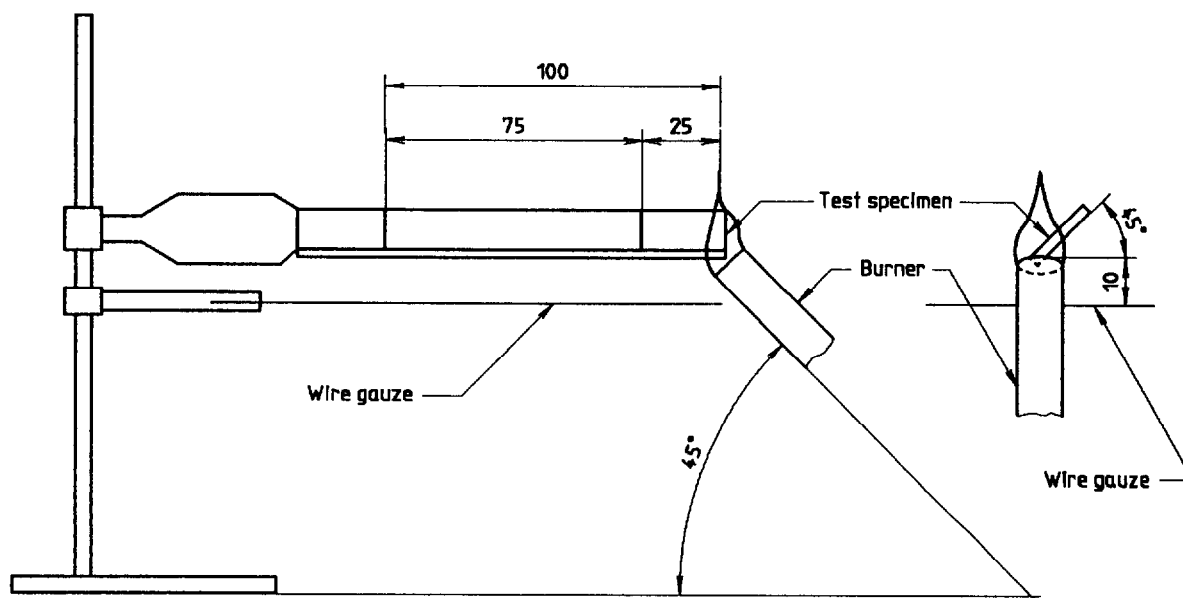

**Figure 1 — Horizontal burning test apparatus (Method A)**

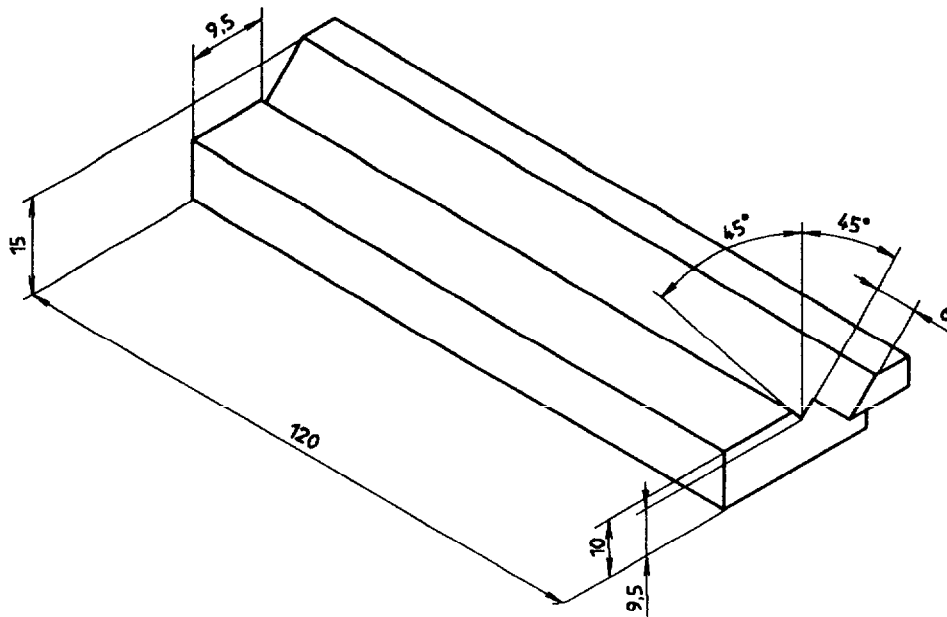

Figure 2 — Flexible-specimen support fixture (Method A)

### 8.3 Conditioning

Unless otherwise required by the specification for the material being tested, two sets of three specimens shall be preconditioned in accordance with ISO 291, at  $23\text{ °C} \pm 2\text{ °C}$  and  $(50 \pm 5)\%$  relative humidity for 48 h. Testing shall be conducted at ambient room conditions within one hour of being conditioned.

### 8.4 Procedure

**8.4.1** Clamp the specimen at the end farthest from the 25 mm mark, with its longitudinal axis horizontal and its transverse axis inclined at  $45^\circ$ . Clamp the wire gauze (8.1.1) horizontally beneath the specimen, with a distance of 10 mm between the lower edge of the specimen and the gauze, and with the free end of the specimen even with the edge of the gauze (see figure 1).

**8.4.2** With the central axis of the burner tube vertical, set the burner (6.2) to produce a blue flame  $20\text{ mm} \pm 2\text{ mm}$  high by adjusting the gas supply (6.6) and air ports of the burner until an approximately 20-mm yellow-tipped blue flame is produced and then increase the air supply until the yellow tip disappears. Measure the height of the flame again and adjust it if necessary.

**8.4.3** If the specimen sags at its free end during initial setting up, position the support fixture (8.1.2) illustrated in figure 2 under the specimen with the small extended portion of the support fixture approximately 20 mm from the free end of the speci-

men. Provide enough clearance at the clamped end of the specimen so that the support fixture can be moved freely sideways. As the combustion front progresses along the specimen, withdraw the support fixture at the same approximate rate.

**8.4.4** Apply the flame to the free end at the lower edge of the specimen so that the central axis of the burner tube is in the same vertical plane as the longitudinal bottom edge of the specimen and inclined towards the end of the specimen at an angle of approximately  $45^\circ$  to the horizontal (figure 1).

**8.4.5** Position the burner so that the flame impinges on the free end of the specimen to a depth of  $6\text{ mm} \pm 1\text{ mm}$ . Apply the test flame for 30 s without changing its position; remove the burner after 30 s, or as soon as the combustion front of the specimen reaches the 25-mm mark (if less than 30 s). Restart the timing device (6.4) when the combustion front reaches the 25-mm mark.

**8.4.6** If the specimen continues to burn (with or without a flame) after application of the test flame, record the time, in seconds, for the combustion front to travel from the 25-mm mark to the 100-mm mark and record the damaged length  $L$ , as 75 mm. If the combustion front passes the 25-mm mark but does not pass the 100-mm mark, record the elapsed time  $t$ , in seconds, and the damaged length  $L$ , in millimetres, between the 25-mm mark and where the combustion front stops.

**8.4.7** Conduct the test procedure on at least three specimens.

## 8.5 Expression of results

**8.5.1** Calculate the linear burning rate  $v$ , in millimetres per minute, for each specimen, using the equation:

$$v = \frac{60L}{t}$$

where

$L$  is the damaged length, in millimetres, as defined in 8.4.6;

$t$  is the time, in seconds, as defined in 8.4.6.

**NOTE 6** The SI unit of linear burning rate is the metre per second. In practice, the unit millimetre per minute is used.

**8.5.2** Calculate the average linear burning rate.

## 8.6 Precision

### 8.6.1 Interlaboratory trials

The precision data were determined from an interlaboratory experiment conducted in 1988 involving ten laboratories, three materials (levels) and three replicates, each using the average of three data points. All tests were conducted on 3-mm-thick specimens. The results were analysed in accordance with ISO 5725, and are summarized in table 1.

**Table 1 — Rate of burning**

Values in millimetres per minute

Parameter	PE	ABS	Acrylic
Average	15,1	27,6	29,7
Repeatability	2,5	5,7	5,2
Reproducibility	3,6	11,4	6,4
NOTE — Material symbols are defined in ISO 1043-1.			

### 8.6.2 Repeatability

In the normal and correct operation of the method, the difference between two averages determined from three specimens using identical test material and the same apparatus by one analyst within a short time interval will not exceed the repeatability value shown in table 1 more than once in 20 cases on average.

### 8.6.3 Reproducibility

In the normal and correct operation of the method, the difference between two independent averages (determined from three specimens) found by two operators working in different laboratories on identical test material will not exceed the reproducibility value shown in table 1 more than once in 20 cases on average.

### 8.6.4 Guidance on precision assessment

The two averages (determined from three specimens) shall be considered suspect and not equivalent if they differ by more than the repeatability and the reproducibility shown in table 1. Any judgement per 8.6.2 or 8.6.3 would have an approximately 95 % (0,95) probability of being correct.

**NOTE 7** Table 1 is only intended to present a meaningful way of considering the approximate precision of this test method for a range of materials. These data should not be rigorously applied to acceptance or rejection of material, as the data are specific to the interlaboratory test and may not be representative of other lots, conditions, thicknesses, materials or laboratories.

## 8.7 Test report

The test report shall include the following particulars:

- a) a reference to this International Standard;
- b) all details necessary to identify the product tested, including the manufacturer's name, number or code;
- c) the thickness, to the nearest 0,1 mm, of the test specimen;
- d) the nominal apparent density (rigid cellular materials only);
- e) the direction of any anisotropy relative to the test specimen dimensions;
- f) any conditioning treatment;
- g) any treatment before testing, other than cutting, trimming and conditioning;
- h) whether or not the combustion front passed the 25-mm and 100-mm marks;
- i) for specimens with which the combustion front passed the 100-mm mark, the average linear burning rate;
- j) whether the flexible specimen support fixture was used.

**9 Method B — Determination of afterflame and/or afterglow times on vertical specimens**

**9.1 Complementary apparatus (see figure 3)**

**9.1.1 Supply of dry, absorbent surgical cotton.**

**9.1.2 Full-draught air-circulating oven,** minimum of five air changes per hour, capable of being maintained at  $70\text{ }^{\circ}\text{C} \pm 1\text{ }^{\circ}\text{C}$  or another agreed temperature.

**9.2 Conditioning**

Unless otherwise required by the material specification, the following shall apply:

**9.2.1** Two sets of 5 bar specimens shall be pre-conditioned for at least  $48\text{ h} + 2\text{ h}$  at  $23\text{ }^{\circ}\text{C} \pm 2\text{ }^{\circ}\text{C}$  and  $(50 \pm 5)\%$  relative humidity.

**9.2.2** Two sets of 5 bar specimens shall be aged for  $168\text{ h} \pm 2\text{ h}$  at  $70\text{ }^{\circ}\text{C} \pm 1\text{ }^{\circ}\text{C}$  and then cooled in the desiccator (6.7) for at least 4 h at ambient temperature.

**9.2.3** All specimens shall be tested in a standard laboratory atmosphere of  $23\text{ }^{\circ}\text{C} \pm 2\text{ }^{\circ}\text{C}$  and  $(50 \pm 5)\%$  relative humidity in accordance with ISO 291.

**9.3 Procedure**

**9.3.1** Clamp the specimen from the upper 6 mm of its length with the longitudinal axis vertical so that the lower end of the specimen is 300 mm above a horizontal 50 mm x 50 mm layer of dry, absorbent surgical cotton (9.1.1) thinned to a maximum uncompressed thickness of 6 mm (see figure 3).

**9.3.2** With the central axis of the burner tube vertical, set the burner (6.2) to produce a blue flame  $20\text{ mm} \pm 2\text{ mm}$  high by adjusting the gas supply (6.6) and air ports of the burner until an approximately 20-mm yellow-tipped blue flame is produced and then increase the air supply until the yellow tip disappears. Measure the height of the flame again and adjust it if necessary.

**9.3.3** Apply the flame of the burner centrally to the middle point of the bottom edge of the specimen so that the top of the burner is 10 mm below that point, and maintain it at that distance for 10 s, moving the burner as necessary in response to any changes in the length or position of the specimen.

Dimensions in millimetres

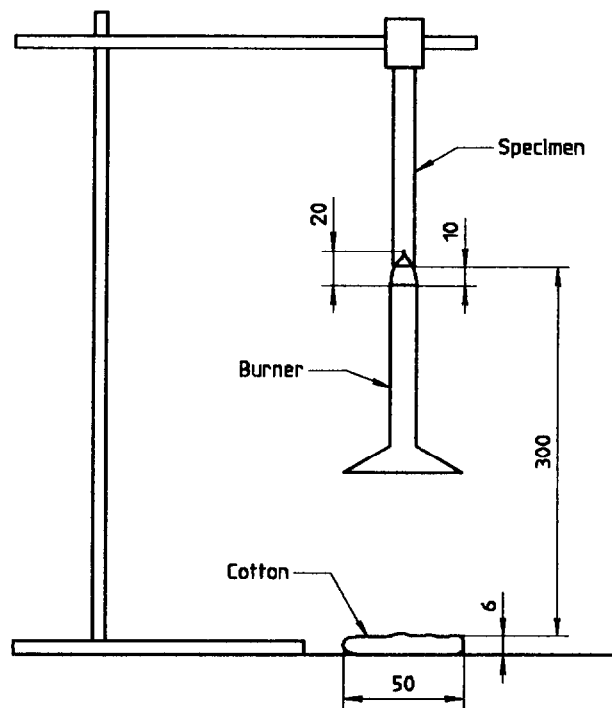

**Figure 3 — Vertical-burning test apparatus (Method B)**



Dimensions in millimetres

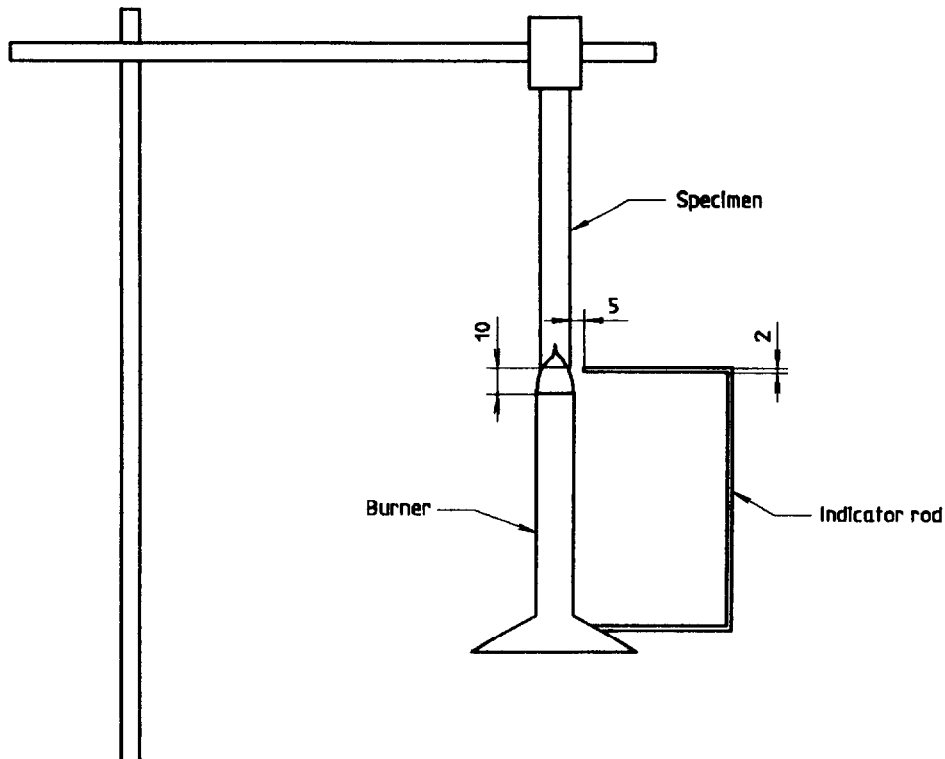

Figure 4 — Optional indicator rod attachment (Method B)

NOTE 8 For specimens which move under the influence of the burner flame, the use of a small indicator rod attached to the burner (as shown in figure 4) has been found to be helpful in maintaining the 10-mm distance between the top of the burner and the major portion of the specimen.

If the specimen drips molten or flaming material during the flame application, tilt the burner at an angle of up to 45° and withdraw it just sufficiently from beneath the specimen to prevent material from dropping into the barrel of the burner while maintaining the 10-mm spacing between the centre of the outlet of the burner and the remaining portion of the specimen, ignoring any strings of molten material. After the application of the flame to the specimen for 10 s, immediately withdraw the burner to a distance at least 150 mm away from the specimen and simultaneously use the timing device to commence measurement of the afterflame time  $t_1$ , in seconds. Note  $t_1$ .

**9.3.4** When afterflaming of the specimen ceases, immediately place the flame and the burner again under the specimen and maintain the burner at a distance of 10 mm from the remaining lower edge of the specimen for 10 s while moving the burner clear of dropping material as necessary, as described in 9.3.3. After this application of the flame to

the specimen for 10 s, immediately extinguish the burner or remove it to a distance of at least 150 mm from the specimen and simultaneously, using the timing device, begin measurement, to the nearest second, of the afterflame time,  $t_2$  and the afterglow time  $t_3$  of the specimen. Note  $t_2$  and  $t_3$ . Note also whether any particles or drips fall from the specimen and, if so, whether they ignite the cotton pad.

**9.3.5** Repeat the procedure until at least five specimens have been tested which were preconditioned in accordance with 9.2.1, and five specimens preconditioned in accordance with 9.2.2.

#### 9.4 Expression of results

For each set of five specimens from the two conditioning treatments, calculate the total afterflame time for the set  $t_t$ , in seconds, using the equation

$$t_t = \sum_{i=1}^5 (t_{1,i} + t_{2,i})$$

where

$t_{1,i}$  is the first afterflame time, in seconds, of the  $i$ th specimen;

$t_{2,i}$  is the second afterflame time, in seconds, of the  $i$ th specimen.

**9.5 Precision**

**9.5.1 Interlaboratory trials**

The precision data were determined from an interlaboratory experiment conducted in 1978 involving four laboratories, four materials (levels) and two replicates each using the average of five data points. The results were analysed in accordance with ISO 5725, and are summarized in table 2.

**9.5.2 Repeatability**

In the normal and correct operation of the method, the difference between two averages determined from five specimens using identical test material and the same apparatus by one analyst within a short time interval will not exceed the reproducibility value shown in table 2 more than once in 20 cases on average.

**9.5.3 Reproducibility**

In the normal and correct operation of the method, the difference between two independent averages (determined from five specimens) found by two operators working in different laboratories on identical material will not exceed the reproducibility value shown in table 2 more than once in 20 cases on average.

**9.5.4 Guidance on precision assessment**

The two averages (determined from five specimens) are to be considered suspect and not equivalent if they differ by more than the repeatability and reproducibility shown in table 2. Any judgement per 9.5.2 or 9.5.3 would have an approximately 95 % (0,95) probability of being correct.

NOTE 9 Table 2 is only intended to present a meaningful way of considering the approximate precision of this test method for a range of materials. These data should not be rigorously applied to acceptance or rejection of material, as the data are specific to the interlaboratory test and may not be representative of other conditions, thicknesses, materials or laboratories.

**9.6 Test report**

The test report shall include the following particulars:

- a) a reference to this International Standard;
- b) all details necessary to identify the product tested, including the manufacturer's name, number or code;
- c) the thickness, to the nearest 0,1 mm, of the test specimen;
- d) the nominal apparent density (rigid cellular materials only);
- e) the direction of any anisotropy relative to the test specimen dimensions;
- f) any conditioning treatment;
- g) any treatment before testing, other than cutting, trimming and conditioning;
- h) the individual values of  $t_1$ ,  $t_2$  and  $t_3$  for each specimen and the average values for each set;
- i) the total afterflame time,  $t_f$ , for each set of five specimens from the two conditioning treatments (see 9.2.1 and 9.2.2);
- j) whether any particles or drips fell from the specimen and whether they ignited the cotton.

**Table 2 — Afterflame and afterflame plus afterglow times**

Values in seconds

Stage	Time measured	Parameter	Material			
			PC	PPO	ABS	PF
After first flame application	Afterflame	Average	1,70	10,05	0,43	0,78
		Repeatability	1,10	10,79	0,83	0,87
		Reproducibility	1,76	12,19	1,26	1,80
After second flame application	Afterflame plus afterglow	Average	3,55	15,95	1,13	49,33
		Repeatability	1,52	14,49	2,16	45,73
		Reproducibility	2,65	13,24	1,89	50,77

NOTE — Symbols for plastics materials are defined in ISO 1043-1.

## Annex A (informative)

### Classification system for determining the burning behaviour of horizontal and vertical specimens in contact with a small-flame ignition source

#### A.1 General

This annex describes a classification system that can be used to characterize the burning behaviour of rigid materials in response to a small-flame ignition source. The use of a category designation code is optional and is determined by examining the test results of materials tested by this method. Each category code represents a preferred range of performance levels that simplifies description in material designations or specifications and may assist certification bodies to determine compliance with applicable requirements.

#### A.2 Category designations

##### A.2.1 Method A

The behaviour of specimens can be classified in one of the following four categories (FH = flaming horizontal):

**FH-1:** No visible flame after the ignition source is removed, or if combustion front does not pass the 25-mm mark.

**FH-2:** Combustion front passes the 25-mm mark but does not pass the 100-mm mark. The length of the burnt area shall be added to the category designation (for example FH-2-70 mm).

**FH-3:** Combustion front passes the 100-mm mark and the linear burning rate does not exceed 40 mm/min for specimens having a thickness between 3 mm and 13 mm or 75 mm/min for specimens having a thickness less than 3 mm. The burning rate shall be added to the category designation (for example FH-3-30 mm/min).

**FH-4:** Same as FH-3 except the linear burning rate exceeds the values specified. The burning rate shall be added to the classification designation (for example FH-4-60 mm/min).

If all the specimens of a material which are tested do not have the same numerical category designation, the category with the highest number is reported as the designation for the material.

##### A.2.2 Method B

The behaviour of specimens may be classified in one of the categories shown in table A.1 (FV = flaming vertical), by selecting the appropriate column using test results to answer the conditional questions posed.

#### A.3 Test report

Recording the category designation in the test report is optional.

**Table A.1 — FV categories**

Conditions	Category <sup>1) 2)</sup>			
	Path 1	Path 2	Path 3	Path 4
If: every individual specimen afterflame time $t_1$ and $t_2$ is And: total set afterflame time $t_f$ for any conditioning is And: every individual specimen afterflame plus afterglow time after the second flame application ( $t_2 + t_3$ ) is And: afterflame or afterglowing progresses up to the holding clamp And: the cotton indicator pad is ignited by flaming particles or drops	$\leq 10$ s $\leq 50$ s $\leq 30$ s No No	$\leq 30$ s $\leq 250$ s $\leq 60$ s No No	$\leq 30$ s $\leq 250$ s $\leq 60$ s No Yes	$> 30$ s $> 250$ s $> 60$ s Yes Yes or no
Then: the category is	FV-0 <sup>3)</sup>	FV-1 <sup>3)</sup>	FV-2 <sup>3)</sup>	— <sup>4)</sup>
1) Select the highest-numbered path in which each individual element complies with the criterion specified. 2) If only one specimen from a set of five specimens for a given preconditioning treatment does not comply with the requirements for a category, another set of five specimens subjected to the same preconditioning shall be tested. All specimens from the second set shall comply with the appropriate requirements for the category. 3) Insert the minimum thickness, in millimetres, to the nearest 0,1 mm, which gives this category. 4) The material cannot be categorized by method B. Use method A (horizontal burning) to categorize the burning behaviour of the material.				

---

---

**UDC (678.5/.8).01:620.1:536.46**

**Descriptors:** plastics, tests, flammability testing, fire tests.

Price based on 10 pages

---

---