

---

---

**Connections for general use and fluid  
power — Ports and stud ends with  
ISO 228-1 threads with elastomeric or  
metal-to-metal sealing —**

**Part 4:  
Stud ends for general use only with  
metal-to-metal sealing (type B)**

*Raccordements pour applications générales et transmissions  
hydrauliques et pneumatiques — Orifices et éléments mâles à filetage  
ISO 228-1 et joint en élastomère ou étanchéité métal sur métal —*

*Partie 4: Éléments mâles pour applications générales uniquement avec  
étanchéité métal sur métal (type B)*



Reference number  
ISO 1179-4:2007(E)

© ISO 2007

**PDF disclaimer**

This PDF file may contain embedded typefaces. In accordance with Adobe's licensing policy, this file may be printed or viewed but shall not be edited unless the typefaces which are embedded are licensed to and installed on the computer performing the editing. In downloading this file, parties accept therein the responsibility of not infringing Adobe's licensing policy. The ISO Central Secretariat accepts no liability in this area.

Adobe is a trademark of Adobe Systems Incorporated.

Details of the software products used to create this PDF file can be found in the General Info relative to the file; the PDF-creation parameters were optimized for printing. Every care has been taken to ensure that the file is suitable for use by ISO member bodies. In the unlikely event that a problem relating to it is found, please inform the Central Secretariat at the address given below.



**COPYRIGHT PROTECTED DOCUMENT**

© ISO 2007

All rights reserved. Unless otherwise specified, no part of this publication may be reproduced or utilized in any form or by any means, electronic or mechanical, including photocopying and microfilm, without permission in writing from either ISO at the address below or ISO's member body in the country of the requester.

ISO copyright office  
Case postale 56 • CH-1211 Geneva 20  
Tel. + 41 22 749 01 11  
Fax + 41 22 749 09 47  
E-mail [copyright@iso.org](mailto:copyright@iso.org)  
Web [www.iso.org](http://www.iso.org)

Published in Switzerland

## Foreword

ISO (the International Organization for Standardization) is a worldwide federation of national standards bodies (ISO member bodies). The work of preparing International Standards is normally carried out through ISO technical committees. Each member body interested in a subject for which a technical committee has been established has the right to be represented on that committee. International organizations, governmental and non-governmental, in liaison with ISO, also take part in the work. ISO collaborates closely with the International Electrotechnical Commission (IEC) on all matters of electrotechnical standardization.

International Standards are drafted in accordance with the rules given in the ISO/IEC Directives, Part 2.

The main task of technical committees is to prepare International Standards. Draft International Standards adopted by the technical committees are circulated to the member bodies for voting. Publication as an International Standard requires approval by at least 75 % of the member bodies casting a vote.

Attention is drawn to the possibility that some of the elements of this document may be the subject of patent rights. ISO shall not be held responsible for identifying any or all such patent rights.

ISO 1179-4 was prepared by Technical Committee ISO/TC 131, *Fluid power systems*, Subcommittee SC 4, *Connectors and similar products and components*.

This first edition of ISO 1179-4, together with ISO 1179-1, ISO 1179-2 and ISO 1179-3, cancels and replaces ISO 1179:1981 which has been technically revised.

ISO 1179 consists of the following parts, under the general title *Connections for general use and fluid power — Ports and stud ends with ISO 228-1 threads with elastomeric or metal-to-metal sealing*:

- *Part 1: Threaded ports*
- *Part 2: Heavy-duty (S series) and light-duty (L series) stud ends with elastomeric sealing (type E)*
- *Part 3: Light-duty (L series) stud ends with sealing by O-ring with retaining ring (types G and H)*
- *Part 4: Stud ends for general use only with metal-to-metal sealing (type B)*

## Introduction

In fluid power systems, power is transmitted and controlled through a fluid (liquid or gas) under pressure within a circuit. In general applications, a fluid may be conveyed under pressure. Components are connected through their threaded ports by fluid conductor connectors to tubes and pipes or to hose fittings and hoses.

For threaded ports and stud ends specified in new designs in hydraulic fluid power applications, ISO/TC 131/SC 4 recommends that the ISO 6149 series be used because these International Standards specify ports and stud ends with metric threads and O-ring sealing and because the sub-committee would like to help users by recommending one preferred system. ISO/TC 131/SC 4 further recommends that threaded ports and stud ends in accordance with the ISO 1179 series, ISO 9974 series and ISO 11926 series not be used for new designs in hydraulic fluid power applications; these International Standards will be maintained because they specify ports and stud ends that are currently used in hydraulic systems worldwide.

For threaded ports and stud ends specified in new designs in pneumatic fluid power applications, ISO/TC 131/SC 4 recommends that ISO 16030 be used, except where products are to interface with ISO 7-1 threads, because the sub-committee would like to help users by recommending one preferred system. ISO/TC 131/SC 4 further recommends that threaded ports and stud ends in accordance with the ISO 1179 series not be used for new designs in pneumatic fluid power applications; these International Standards will be maintained because they specify ports and stud ends that are currently used in pneumatic systems worldwide.

Significant testing over more than 30 years of use has confirmed the performance requirements of connection ends made from carbon steel. The stud end connections specified in ISO 1179 parts 2, 3 and 4 apply to connectors detailed in ISO 8434 parts 1, 2 and 4.

# Connections for general use and fluid power — Ports and stud ends with ISO 228-1 threads with elastomeric or metal-to-metal sealing —

## Part 4: Stud ends for general use only with metal-to-metal sealing (type B)

### 1 Scope

This part of ISO 1179 specifies dimensions, performance requirements and test procedures for stud ends with ISO 228-1 threads and metal-to-metal sealing for general use only. These stud ends should not be used for leak-free hydraulic fluid power applications.

Stud ends in accordance with this part of ISO 1179 may be used at working pressures up to 40 MPa (400 bar) for the S series, up to 25 MPa (250 bar) for the L series, and up to 10 MPa (100 bar) for the LL series. The permissible working pressure depends upon size, materials, design, working conditions, application, etc.

Conformance to the dimensional information in this part of ISO 1179 does not guarantee rated performance. Each manufacturer shall perform tests according to the specification contained in this part of ISO 1179 in order to ensure that components made to this part of ISO 1179 comply with the performance ratings.

NOTE 1 This part of ISO 1179 applies to connectors detailed in ISO 8434-1 and ISO 8434-2.

NOTE 2 The introduction of this part of ISO 1179 gives recommendations for ports and stud ends to be used for new designs in hydraulic and pneumatic fluid power applications.

### 2 Normative references

The following referenced documents are indispensable for the application of this document. For dated references, only the edition cited applies. For undated references, the latest edition of the referenced document (including any amendments) applies.

ISO 228-1, *Pipe threads where pressure-tight joints are not made on the threads — Part 1: Dimensions, tolerances and designation*

ISO 4759-1:2000, *Tolerances for fasteners — Part 1: Bolts, screws, studs and nuts — Product grades A, B and C*

ISO 5598, *Fluid power systems and components — Vocabulary*

ISO 19879, *Metallic tube connections for fluid power and general use — Test methods for hydraulic fluid power connections*

### 3 Terms and definitions

For the purposes of this document, the terms and definitions given in ISO 5598 apply.

### 4 Dimensions

ISO 1179-4 stud ends shall conform to the dimensions given in Figure 1 and Table 1. Hexagonal tolerances across flats shall be according to ISO 4759-1:2000, product grade C.

### 5 Requirements

#### 5.1 Working pressure

ISO 1179-4 stud ends made of low carbon steel shall be designed for use at the working pressures given in Table 2.

#### 5.2 Performance

ISO 1179-4 stud ends made of low carbon steel shall meet or exceed the burst and impulse pressures given in Table 2, when tested in accordance with Clause 7 and assembled using the torques in Table 3.

### 6 Metal-to-metal sealing

The machined seal edge is compressed during assembly. This causes damage to the sealing face of the port. Safe reassembly is not possible. A high surface pressure is required, otherwise leakage is possible.

### 7 Test methods

#### 7.1 Burst pressure test (failure pressure test)

##### 7.1.1 Principle

Three samples shall be tested to confirm that ISO 1179-4 stud ends meet or exceed a ratio of 4:1 between the burst and working pressures.

##### 7.1.2 Materials — Test block and stud ends

Test blocks shall be in accordance with the requirements specified in ISO 19879. Stud ends shall be made from low carbon steel and be plated.

##### 7.1.3 Procedure

###### 7.1.3.1 Thread lubrication

For testing only, threads and contact surfaces shall be lubricated in accordance with the requirements of ISO 19879.

###### 7.1.3.2 Stud end torque

Stud ends shall be tested after application of the torques given in Table 3.

### 7.1.3.3 Pressure rise rate

The rate of pressure rise shall be in accordance with the requirements of ISO 19879.

## 7.2 Cyclic endurance (impulse) test

### 7.2.1 Principle

Six samples, when tested at their respective impulse pressures, shall pass a cyclic endurance test of 1 000 000 cycles.

### 7.2.2 Materials

Use the same materials as specified in 7.1.2.

### 7.2.3 Procedure

#### 7.2.3.1 Thread lubrication

Apply lubricant as specified in 7.1.3.1.

#### 7.2.3.2 Stud end torques

Apply torque as specified in 7.1.3.2.

#### 7.2.3.3 Cycle and pressure rise rate

The cycle rate shall be in accordance with the requirements of ISO 19879, except the rate of pressure rise shall be adjusted accordingly.

## 7.3 Test report

Test results and conditions shall be reported on the test data form given in Annex A.

## 7.4 Re-use of components

Parts used for cyclic endurance or burst test shall not be tested further, used or returned to stock.

## 8 Designation of stud ends

Stud ends shall be designated by:

- a) "Stud end";
- b) reference to this part of ISO 1179, i.e. ISO 1179-4;
- c) thread size;
- d) the letter symbol for the relevant series.

EXAMPLE A stud end with a G 3/8 A thread in accordance with ISO 228-1 is designated as follows:

**Stud end ISO 1179-4 - G 3/8 A-S**

**9 Identification statement** (reference to this part of ISO 1179)

Use the following statement in test reports, catalogues and sales literature when electing to comply with this part of ISO 1179:

“Stud end for general use only conforms to ISO 1179-4, *Connections for general use and fluid power — Ports and stud ends with ISO 228-1 threads with elastomeric or metal-to-metal sealing — Part 4: Stud ends for general use only with metal-to-metal sealing (type B).*”

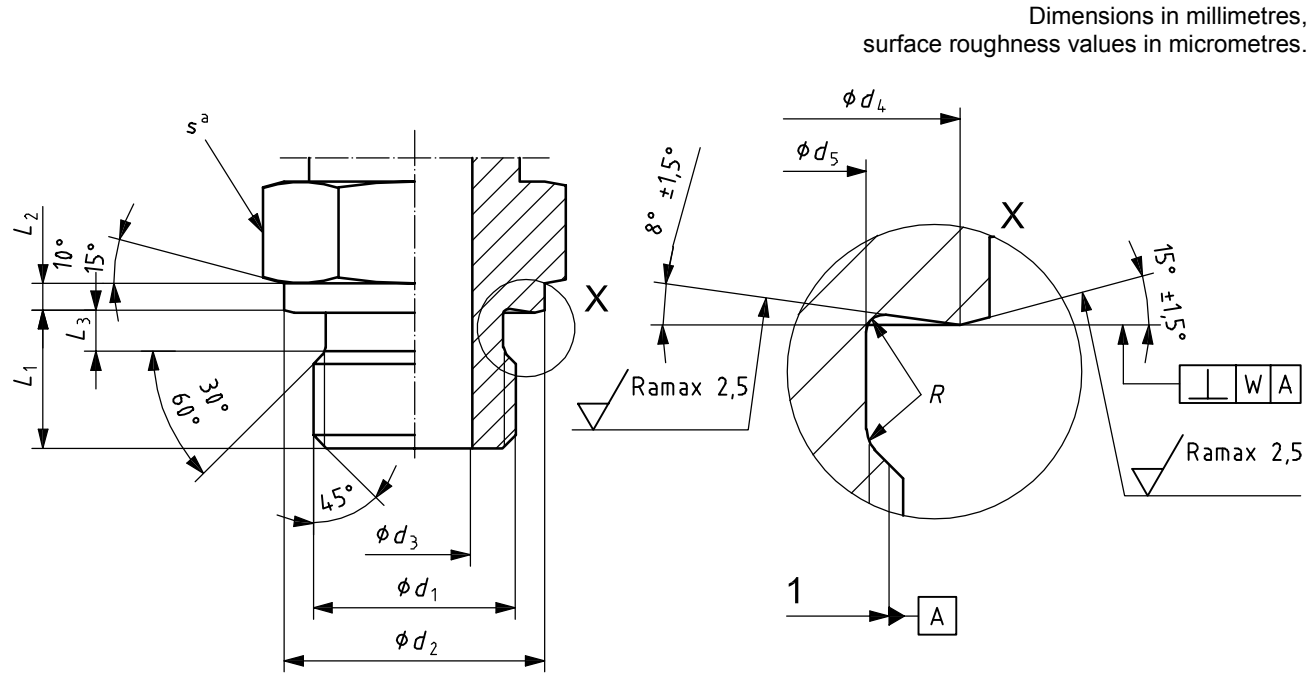

- Key**
- 1 thread pitch diameter
  - a Dimension across the flats.

**Figure 1 — ISO 1179-4 stud end for general use only with metal-to-metal sealing (type B)**

**Table 1 — Dimensions for ISO 1179-4 stud ends for general use only with metal-to-metal sealing (type B)**

Dimensions in millimetres

Thread size $d_1$	$d_2$	$d_3$ maximum drill size						$d_4$	$d_5$	$L_1$	$L_2$	$L_3$	$R$	$s$ hex	$W$
		LL series	tol.	L series	tol.	S series	tol.								
G 1/8 A	14	4	$\pm 0,1$	4	$\pm 0,1$	—	—	13	8,3	8	1,5	2	1	14	0,1
G 1/4 A	18	—	—	6	$\pm 0,1$	5	$\pm 0,1$	17	11,2	12	2	3	1,2	19	0,1
G 3/8 A	22	—	—	9	$\pm 0,2$	8	$\pm 0,2$	21	14,7	12	2,5	3	1,2	22	0,1
G 1/2 A	26	—	—	14	$\pm 0,2$	12	$\pm 0,2$	25	18,4	14	3	4	1,2	27	0,1
G 3/4 A	32	—	—	18	$\pm 0,2$	16	$\pm 0,2$	30	23,9	16	3	4	1,2	32	0,2
G 1 A	39	—	—	23	$\pm 0,2$	20	$\pm 0,2$	37	29,9	18	3	5	1,6	41	0,2
G 1 1/4 A	49	—	—	30	$\pm 0,2$	25	$\pm 0,2$	47	38,6	20	3	5	1,6	50	0,2
G 1 1/2 A	55	—	—	36	$\pm 0,3$	32	$\pm 0,3$	53	44,5	22	3	5	1,6	55	0,2



Table 2 — Pressures for ISO 1179-4 stud ends for general use only with metal-to-metal sealing (type B) <sup>a</sup>

Series	Thread size	Working pressure		Test pressure			
		MPa	(bar)	Burst		Impulse <sup>b</sup>	
				MPa	(bar)	MPa	(bar)
<b>LL</b>	G 1/8 A	10	(100)	40	(400)	13,3	(133)
<b>L</b>	G 1/8 A	25	(250)	100	(1 000)	33,2	(332)
	G 1/4 A	25	(250)	100	(1 000)	33,2	(332)
	G 3/8 A	25	(250)	100	(1 000)	33,2	(332)
	G 1/2 A	25	(250)	100	(1 000)	33,2	(332)
	G 3/4 A	16	(160)	64	(640)	21,3	(213)
	G 1 A	10	(100)	40	(400)	13,3	(133)
	G 1 1/4 A	10	(100)	40	(400)	13,3	(133)
	G 1 1/2 A	10	(100)	40	(400)	13,3	(133)
<b>S</b>	G 1/4 A	40	(400)	160	(1 600)	53,2	(532)
	G 3/8 A	40	(400)	160	(1 600)	53,2	(532)
	G 1/2 A	40	(400)	160	(1 600)	53,2	(532)
	G 3/4 A	40	(400)	160	(1 600)	53,2	(532)
	G 1 A	25	(250)	100	(1 000)	33,2	(332)
	G 1 1/4 A	16	(160)	64	(640)	21,3	(213)
	G 1 1/2 A	16	(160)	64	(640)	21,3	(213)
<sup>a</sup>	These pressures were established using connectors made of low carbon steel and tested in accordance with Clause 7.						
<sup>b</sup>	Cyclic endurance test pressure.						

Table 3 — Stud qualification test torques

Series	Thread size	Torque
		Nm + 10 % - 0 %
<b>LL</b>	G 1/8 A	15
<b>L</b>	G 1/8 A	20
	G 1/4 A	40
	G 3/8 A	80
	G 1/2 A	150
	G 3/4 A	200
	G 1 A	380
	G 1 1/4 A	600
	G 1 1/2 A	700
	G 1/4 A	60
<b>S</b>	G 3/8 A	100
	G 1/2 A	170
	G 3/4 A	320
	G 1 A	380
	G 1 1/4 A	600
	G 1 1/2 A	800

NOTE These torque values are for testing only. Assembly tightening torque depends on many factors, including lubrication, coating and surface finish. The manufacturer should be consulted.

## Annex A (normative)

### Test data form for ISO 1179-1 port and ISO 1179-4 stud ends

<b>Stud end specifications:</b>				
Manufacturer		Test facility		
Stud end type		Size		
Minimum material tensile strength				MPa
Stud end working pressure (see Table 2):				MPa
Stud end impulse test pressure (see Table 2):				MPa
Stud end burst test pressure (see Table 2):				MPa
Qualification test assembly torque (see Table 3):				Nm
<b>Burst test results:</b> minimum number of samples tested = 3				
Sample No.	Pressure at failure	Torque	Hardness	Type of failure
1	MPa	Nm	HRB	
2	MPa	Nm	HRB	
3	MPa	Nm	HRB	
<b>Cyclic endurance test results:</b> minimum number of samples tested = 6				
Sample No.	Hardness	Torque	Cycles at failure	Type of failure
1	HRB	Nm		
2	HRB	Nm		
3	HRB	Nm		
4	HRB	Nm		
5	HRB	Nm		
6	HRB	Nm		
<b>Conclusions:</b> Pass/fail, with reason for failure				
Dimensions (list any exceptions):				
Name (printed/typed) and signature of person certifying report:				Date:

## Bibliography

- [1] ISO 7-1, *Pipe threads where pressure-tight joints are made on the threads — Part 1: Dimensions, tolerances and designation*
- [2] ISO 1101, *Geometrical Product Specifications (GPS) — Geometrical tolerancing — Tolerances of form, orientation, location and run-out*
- [3] ISO 1302, *Geometrical Product Specifications (GPS) — Indication of surface texture in technical product documentation*
- [4] ISO 6149-1, *Connections for hydraulic fluid power and general use — Ports and stud ends with ISO 261 metric threads and O-ring sealing — Part 1: Ports with truncated housing for O-ring seal*
- [5] ISO 6149-2, *Connections for hydraulic fluid power and general use — Ports and stud ends with ISO 261 metric threads and O-ring sealing — Part 2: Dimensions, design, test methods and requirements for heavy-duty (S series) stud ends*
- [6] ISO 6149-3, *Connections for hydraulic fluid power and general use — Ports and stud ends with ISO 261 metric threads and O-ring sealing — Part 3: Dimensions, design, test methods and requirements for light-duty (L series) stud ends*
- [7] ISO 8434-1, *Metallic tube connections for fluid power and general use — Part 1: 24° cone connectors*
- [8] ISO 8434-2, *Metallic tube connections for fluid power and general use — Part 2: 37° flared connectors*
- [9] ISO 8434-4, *Metallic tube connections for fluid power and general use — Part 4: 24° cone connectors with O-ring weld-on nipples*
- [10] ISO 9974-1, *Connections for general use and fluid power — Ports and stud ends with ISO 261 threads with elastomeric or metal-to-metal sealing — Part 1: Threaded ports*
- [11] ISO 9974-2, *Connections for general use and fluid power — Ports and stud ends with ISO 261 threads with elastomeric or metal-to-metal sealing — Part 2: Stud ends with elastomeric sealing (type E)*
- [12] ISO 9974-3, *Connections for general use and fluid power — Ports and stud ends with ISO 261 threads with elastomeric or metal-to-metal sealing — Part 3: Stud ends with metal-to-metal sealing (type B)*
- [13] ISO 11926-1, *Connections for general use and fluid power — Ports and stud ends with ISO 725 threads and O-ring sealing — Part 1: Ports with O-ring seal in truncated housing*
- [14] ISO 11926-2, *Connections for general use and fluid power — Port and stud ends with ISO 725 threads and O-ring sealing — Part 2: Heavy-duty (S series) stud ends*
- [15] ISO 11926-3, *Connections for general use and fluid power — Port and stud ends with ISO 725 threads and O-ring sealing — Part 3: Light-duty (L series) stud ends*
- [16] ISO 16030, *Pneumatic fluid power — Connections — Ports and stud ends*

This page is intentionally blank.

This page is intentionally blank.

This page is intentionally blank.

---

---

**ICS 23.100.40**

Price based on 8 pages

© ISO 2007 – All rights reserved