**Thermoplastics pipes, fittings and
assemblies for the conveyance of
fluids — Determination of the resistance
to internal pressure —**

**Part 3:
Preparation of components**

*Tubes, raccords et assemblages en matières thermoplastiques pour le
transport des fluides — Détermination de la résistance à la pression
interne —*

Partie 3: Préparation des composants



PDF disclaimer

This PDF file may contain embedded typefaces. In accordance with Adobe's licensing policy, this file may be printed or viewed but shall not be edited unless the typefaces which are embedded are licensed to and installed on the computer performing the editing. In downloading this file, parties accept therein the responsibility of not infringing Adobe's licensing policy. The ISO Central Secretariat accepts no liability in this area.

Adobe is a trademark of Adobe Systems Incorporated.

Details of the software products used to create this PDF file can be found in the General Info relative to the file; the PDF-creation parameters were optimized for printing. Every care has been taken to ensure that the file is suitable for use by ISO member bodies. In the unlikely event that a problem relating to it is found, please inform the Central Secretariat at the address given below.



COPYRIGHT PROTECTED DOCUMENT

© ISO 2007

All rights reserved. Unless otherwise specified, no part of this publication may be reproduced or utilized in any form or by any means, electronic or mechanical, including photocopying and microfilm, without permission in writing from either ISO at the address below or ISO's member body in the country of the requester.

ISO copyright office
Case postale 56 • CH-1211 Geneva 20
Tel. + 41 22 749 01 11
Fax + 41 22 749 09 47
E-mail copyright@iso.org
Web www.iso.org

Published in Switzerland

Contents

Page

Foreword.....	iv
1 Scope	1
2 Normative references	1
3 Principle	1
4 Pressure-tight devices	2
4.1 General	2
4.2 Components with plain sockets	2
4.3 Components with socket and gasket	5
4.4 Closing devices for valve bodies	6
5 Test pieces	8
5.1 Sampling	8
5.2 Preparation of test pieces	9
6 Test report	9

Foreword

ISO (the International Organization for Standardization) is a worldwide federation of national standards bodies (ISO member bodies). The work of preparing International Standards is normally carried out through ISO technical committees. Each member body interested in a subject for which a technical committee has been established has the right to be represented on that committee. International organizations, governmental and non-governmental, in liaison with ISO, also take part in the work. ISO collaborates closely with the International Electrotechnical Commission (IEC) on all matters of electrotechnical standardization.

International Standards are drafted in accordance with the rules given in the ISO/IEC Directives, Part 2.

The main task of technical committees is to prepare International Standards. Draft International Standards adopted by the technical committees are circulated to the member bodies for voting. Publication as an International Standard requires approval by at least 75 % of the member bodies casting a vote.

Attention is drawn to the possibility that some of the elements of this document may be the subject of patent rights. ISO shall not be held responsible for identifying any or all such patent rights.

ISO 1167-3 was prepared by Technical Committee ISO/TC 138, *Plastics pipes, fittings and valves for the transport of fluids*, Subcommittee SC 5, *General properties of pipes, fittings and valves of plastic materials and their accessories — Test methods and basic specifications*.

This first edition of ISO 1167-3, together with ISO 1167-2, cancels and replaces ISO 12092:2000, of which it constitutes a technical revision.

ISO 1167-3 consists of the following parts, under the general title *Thermoplastics pipes, fittings and assemblies for the conveyance of fluids — Determination of the resistance to internal pressure*:

- *Part 1: General method*
- *Part 2: Preparation of pipe test pieces*
- *Part 3: Preparation of components*
- *Part 4: Preparation of assemblies*

Thermoplastics pipes, fittings and assemblies for the conveyance of fluids — Determination of the resistance to internal pressure —

Part 3: Preparation of components

1 Scope

This part of ISO 1167 specifies the procedure for the preparation of components, i.e. fittings and valve bodies, for the determination of their resistance to internal hydrostatic pressure according to ISO 1167-1.

NOTE Polyolefin fittings for butt fusion, electrofusion and socket fusion are usually tested as an assembly and are treated in ISO 1167-4.

2 Normative references

The following referenced documents are indispensable for the application of this document. For dated references, only the edition cited applies. For undated references, the latest edition of the referenced document (including any amendments) applies.

ISO 1167-1:2006, *Thermoplastics pipes, fittings and assemblies for the conveyance of fluids — Determination of the resistance to internal pressure — Part 1: General method*

3 Principle

Test pieces, each comprising a single component with its appropriate sealing devices or a pipe-component assembly, are mounted with end caps or alternative means to arrive at a pressure-tight test piece assembly. Following conditioning at the specified test temperature, these test pieces are subjected to the internal hydrostatic pressure according to ISO 1167-1 for a specified period of time or until the test piece(s) fail(s).

The number of test pieces, conditioning and details of the test report are as given in ISO 1167-1.

NOTE It is assumed that the following test parameters (see 5.1) are set by the standard making reference to this part of ISO 1167 and, respectively, to ISO 1167-1:

- a) the sampling requirements;
- b) the period of time between the date of production of the parts and the tests.

4 Pressure-tight devices

4.1 General

Pressure-tight devices shall allow sealing and connection of components with the pressurizing equipment and a means of purging the air before testing. The devices shall not prevent the free parts of components, between joints, from deforming under the action of hydrostatic pressure for the duration of the test. External reinforcing rings may be used to prevent any leakage from the joint for the required duration of the test. The external reinforcing rings and the internal seal shall be located within the area of the socket.

The openings in the pressure-bearing component shall be closed off such that all air is expelled and the test piece can be tested in a safe manner without any negative effect on the test results.

The devices shall be in accordance with 4.2.1, 4.2.2 or 4.2.3, as applicable, or shall be of one of the types specified in 4.2.4 or 4.3.

The type of pressure-tight devices shall be identified in the test report (see Clause 6).

4.2 Components with plain sockets

4.2.1 Joints using pipes and/or end caps

See Figure 1.

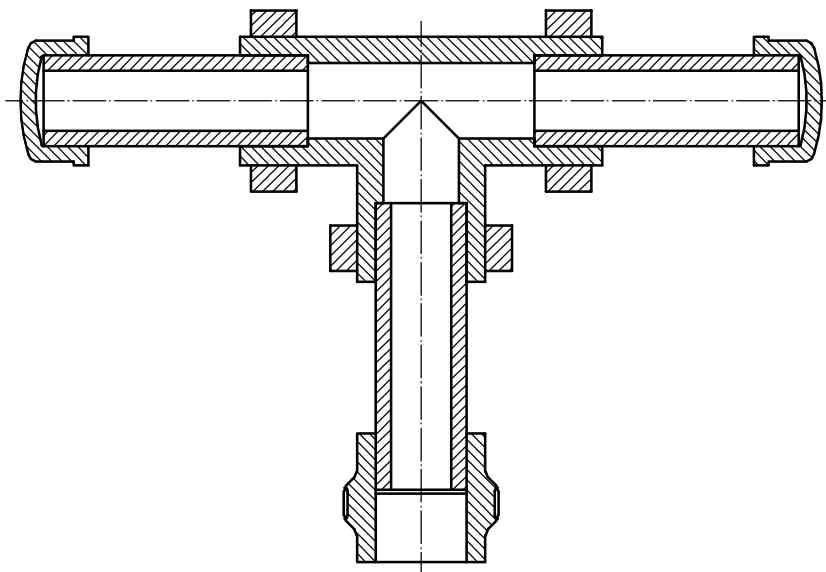

Figure 1 — Example of pressure-tight test piece with hydrostatic end thrust

Each of the sockets of the component shall be joined to a portion of pipe and/or end cap of the series for which it is designed. The pipe ends shall be prepared in accordance with the requirements of the joint design. The free length of the pipes shall be such that the connectors can be fixed without difficulty and shall be as short as possible.

IMPORTANT — Care shall be taken that no additional stress is induced by the pressure-tight devices.

4.2.2 Mechanical joint using external threads or machined grooves

See Figure 2.

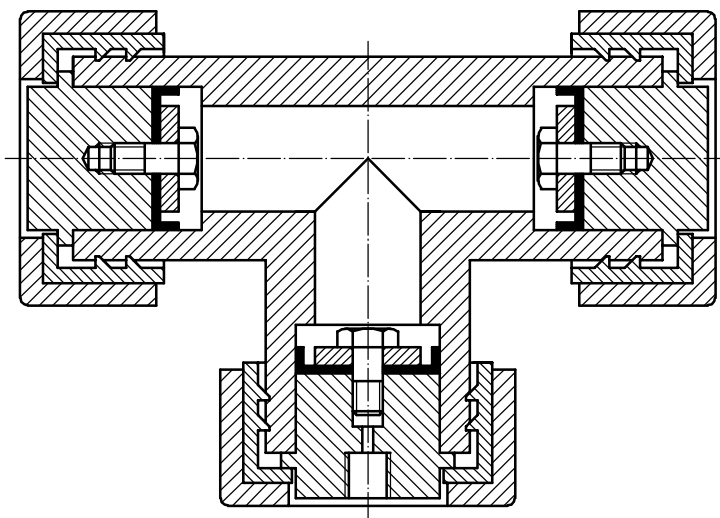

Figure 2 — Example of pressure-tight test piece with mechanical joints involving external threads or machined grooves and with hydrostatic end thrust

The closing device shall be attached to the test piece by means of the engagement of its ribs with the external threads or machined grooves in the test piece. Sealing shall be ensured by cup-shaped seals inside the socket of the test piece.

Machining of the grooves shall be carried out with great care, taking into account the notch sensitivity of the plastics material concerned. The number and depth of the grooves shall be selected to ensure that the stress in the component at the level of the grooves is within acceptable limits.

4.2.3 Mechanical joint using compression by means of ribbed half-segments

See Figure 3.

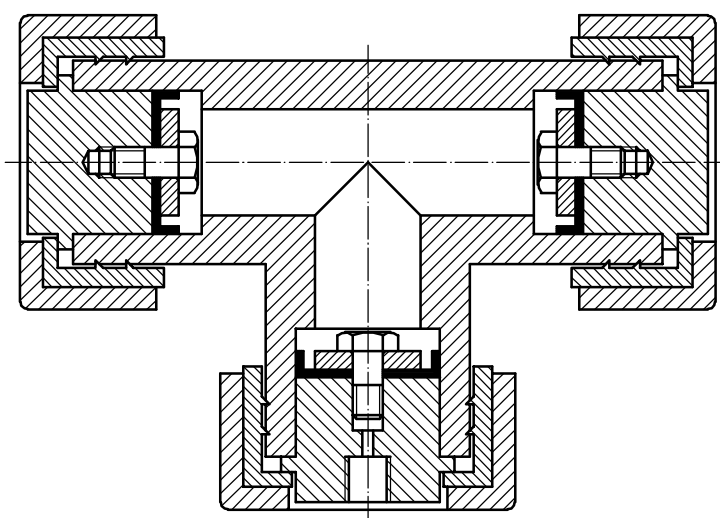

Figure 3 — Example of pressure-tight test piece with mechanical compression joints and hydrostatic end thrust

The grooves in the test piece are formed by pressing the ribs of the half or split shells of the closing device into the test piece. The closing device shall be held to the test piece by the ribs engaging the grooves. Sealing shall be ensured by cup-shaped seals inside the socket of the test piece.

The number and height of the ribs forming the grooves in the test piece shall be selected to ensure that the stress in the component at the level of the grooves is within acceptable limits, taking into account the notch sensitivity of the plastics material concerned.

NOTE The principle of the joint shown in Figure 3 avoids machining and reduces the risk of defects caused by the production of the grooves.

4.2.4 Joint using internal metal pins to prevent expulsion of connectors

See Figure 4.

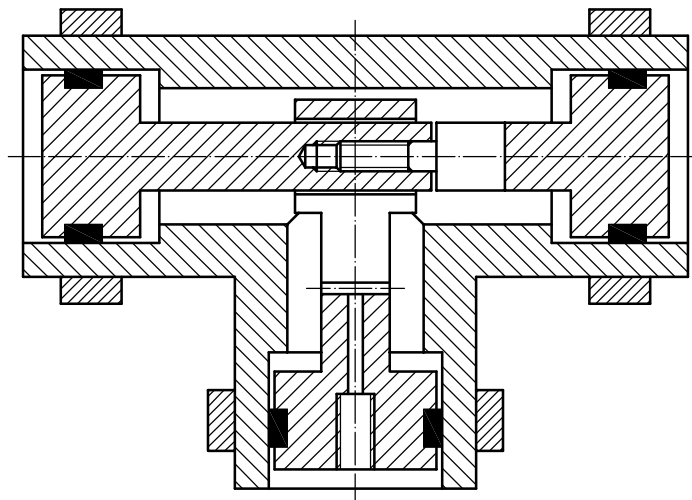

Figure 4 — Example of pressure-tight test piece with internally pinned joints and ring seals and without hydrostatic end thrust

The internally located closing pistons shall be held together by an appropriate coupling design. Sealing shall be ensured by ring seals inside the socket of the test piece, supported by external reinforcing rings.

NOTE The principle illustrated in Figure 4 avoids the influence of notches caused by the gripping or retaining devices. A possible influence on the deformation of the free parts and the superimposing of additional forces due to the rigidity of the metal pins is not excluded.

4.3 Components with socket and gasket

4.3.1 Joint with elastomer gasket using internal metal pins to prevent expulsion of connectors

See Figure 5.

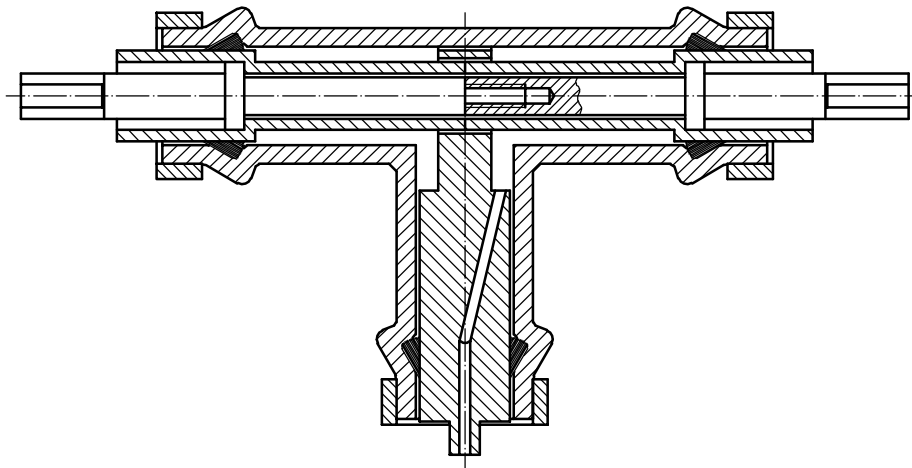

Figure 5 — Example of pressure-tight test piece with internally pinned joints and gasket seals and without hydrostatic end thrust

The internally located closing pistons shall be held together by an appropriate coupling design. Sealing shall be ensured by the original seals inside the push-fit socket of the test piece, supported by external reinforcing rings.

IMPORTANT — Care should be taken that no additional stress is induced in the test piece by forces resulting from the piston arrangement.

4.3.2 Joint with elastomer gasket using external frame

See Figure 6.

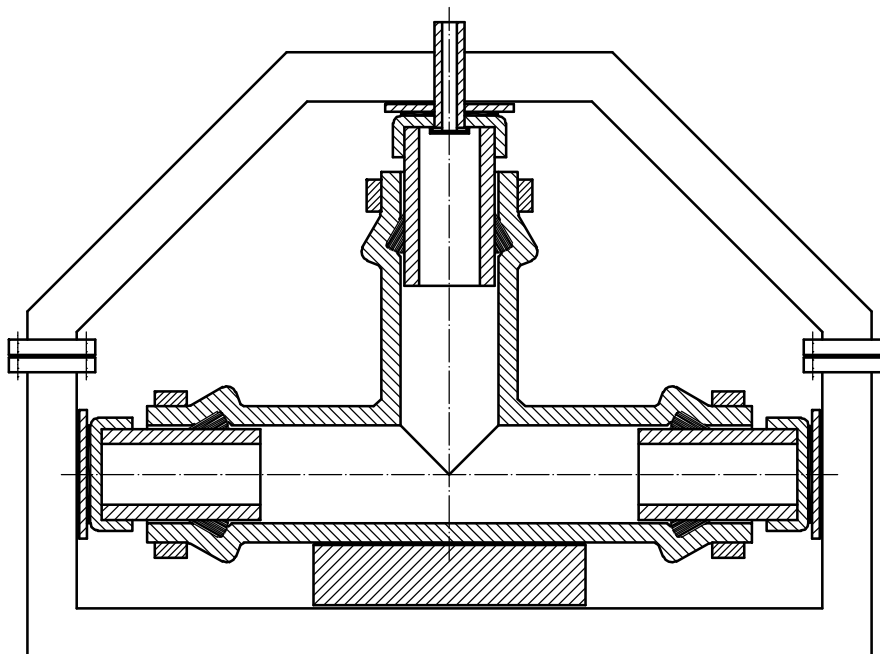

Figure 6 — Example of pressure-tight test piece using devices involving external frame and without hydrostatic end thrust

The internally located closing pistons shall be held together by an appropriate coupling design (external frame). Sealing shall be ensured by the original seals inside the push-fit socket of the test piece. All pipe ends shall be chamfered if specified by the fitting manufacturer.

IMPORTANT — Care should be taken that no additional stress is induced in the test piece by forces resulting from the piston arrangement or the support.

4.3.3 Joint with elastomer gasket using external half-segments

See Figure 7.

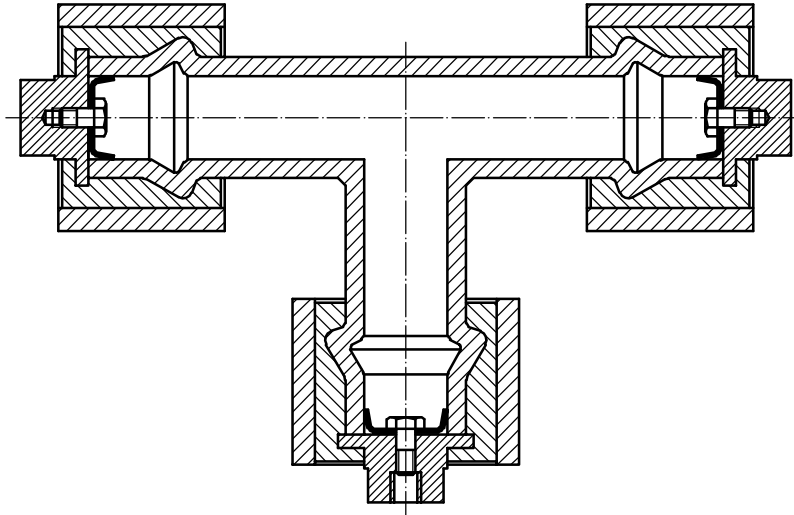

Figure 7 — Example of pressure-tight test piece using devices with external half-segments for jointing and with hydrostatic end thrust

The closing device shall be attached to the test piece by the engagement of the shoulder of the test piece into the half-segments. Sealing shall be ensured by cup-shaped seals inside the socket of the test piece.

4.4 Closing devices for valve bodies

4.4.1 Ball valve with union connection

See Figure 8.

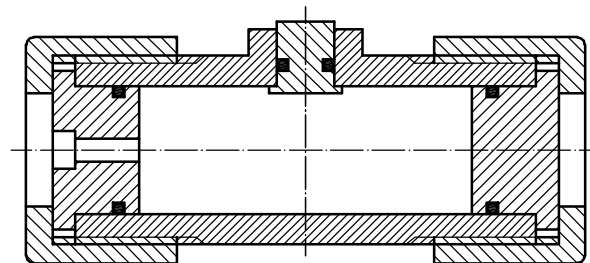

Figure 8 — Example of pressure-tight device using metal plugs and nuts on ball valve body

All openings shall be closed with plugs and O-rings. Special metal nuts may be used in place of the original plastics nuts to keep the plugs in place.

The plugs should preferably not be inserted deeper into the valve body than the original components in an assembled valve.

4.4.2 Diaphragm valves with spigots

See Figure 9.

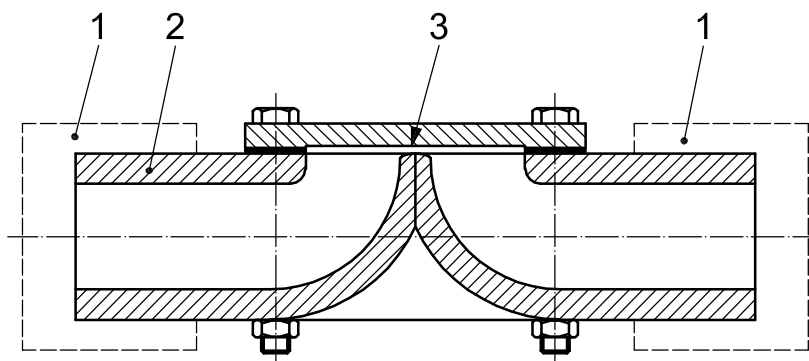

Key

- 1 valve body
- 2 end connector
- 3 metal plate and seal

Figure 9 — Example of a pressure-tight device on a diaphragm valve body

The diaphragm, which is usually the limiting valve component with regard to internal pressure and temperature, may be replaced by a metal plate and a sealing gasket. To close the inlet and outlet of the valve body, the same types of closing device may be used as for fittings.

NOTE This arrangement does not exactly simulate the stress situation in an assembled valve. It does, however, allow a pressure test to be carried out on the valve body irrespective of the diaphragm used. The real performance of an assembled valve can only be assessed on an assembled valve.

4.4.3 Seat valves with spigots

See Figure 10.

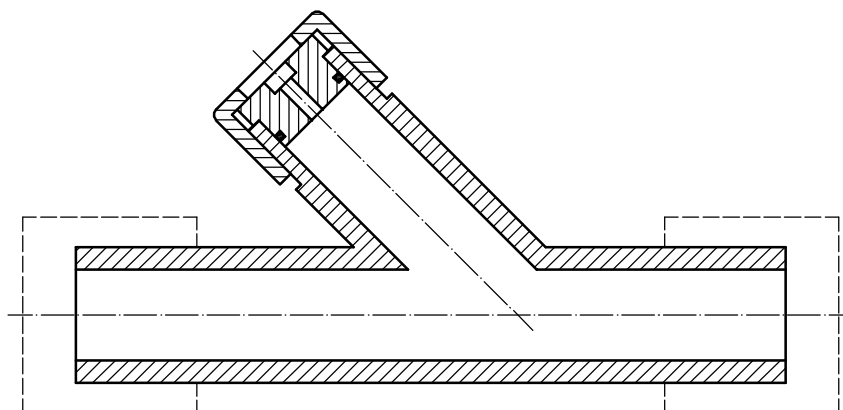

Figure 10 — Example of pressure-tight device on seat valve body

The actuator openings shall be closed off by a plug, an O-ring and a metal nut. To close the inlet and outlet of the valve body, the same types of closing device may be used as for fittings.

The plugs should preferably not be inserted deeper into the valve body than the original components in an assembled valve.

NOTE This arrangement does not exactly simulate the stress situation in an assembled valve. It does, however, allow a pressure test to be carried out on the valve body irrespective of the closing mechanism used. The real performance of an assembled valve can only be assessed on an assembled valve.

4.4.4 Butterfly valves

See Figure 11.

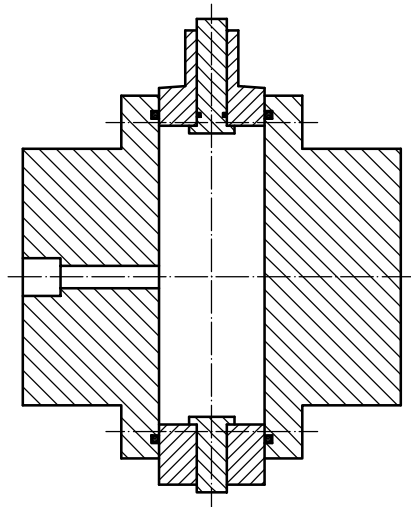

Figure 11 — Example of pressure-tight device for butterfly valve body

The openings for the valve shaft shall be sealed by metal plugs with O-rings. Shoulders on the metal plugs prevent a blow out during pressurization. The inlet and outlet may be closed off by blind flanges and seals. The type of bolt used for the assembly of the blind flanges should preferably be of the same type as that used for actual installation of an assembled valve.

The plugs should preferably not be inserted deeper into the valve body than the original components in an assembled valve.

NOTE This arrangement does not exactly simulate the stress situation in an assembled valve. It does, however, allow a pressure test to be carried out on the valve body irrespective of the type of seal used. The real performance of an assembled valve can only be assessed on an assembled valve.

5 Test pieces

5.1 Sampling

The sampling requirements shall be as specified in the relevant product standards.

The period of time between the date of production of the parts and the tests, which will depend on the type of material, shall be as given in the general specifications for the material. For materials where no general specifications are available, the minimum time between production and test shall be as specified by the conditioning requirements.

5.2 Preparation of test pieces

The test piece shall comprise a complete fitting, valve body or other pressure-bearing component, of given type and nominal diameter, together with its connectors and, where applicable, held by a frame.

The test piece preparation shall be in accordance with the procedures specified by the manufacturer.

Assembly of the test pieces shall be carried out at ambient temperature.

6 Test report

Record the information required in accordance with ISO 1167-1:2006, Clause 11.

This page is intentionally blank.

This page is intentionally blank.

