

INTERNATIONAL STANDARD

ISO 1161

Fourth edition
1984-12-15

AMENDMENT 1
2007-07-01

Series 1 freight containers — Corner fittings — Specification

AMENDMENT 1: 45 ft containers

Conteneurs de la série 1 — Pièces de coin — Spécifications

AMENDEMENT 1: Conteneurs 45 ft



Reference number
ISO 1161:1984/Amd.1:2007(E)

© ISO 2007

PDF disclaimer

This PDF file may contain embedded typefaces. In accordance with Adobe's licensing policy, this file may be printed or viewed but shall not be edited unless the typefaces which are embedded are licensed to and installed on the computer performing the editing. In downloading this file, parties accept therein the responsibility of not infringing Adobe's licensing policy. The ISO Central Secretariat accepts no liability in this area.

Adobe is a trademark of Adobe Systems Incorporated.

Details of the software products used to create this PDF file can be found in the General Info relative to the file; the PDF-creation parameters were optimized for printing. Every care has been taken to ensure that the file is suitable for use by ISO member bodies. In the unlikely event that a problem relating to it is found, please inform the Central Secretariat at the address given below.



COPYRIGHT PROTECTED DOCUMENT

© ISO 2007

All rights reserved. Unless otherwise specified, no part of this publication may be reproduced or utilized in any form or by any means, electronic or mechanical, including photocopying and microfilm, without permission in writing from either ISO at the address below or ISO's member body in the country of the requester.

ISO copyright office
Case postale 56 • CH-1211 Geneva 20
Tel. + 41 22 749 01 11
Fax + 41 22 749 09 47
E-mail copyright@iso.org
Web www.iso.org

Published in Switzerland

Foreword

ISO (the International Organization for Standardization) is a worldwide federation of national standards bodies (ISO member bodies). The work of preparing International Standards is normally carried out through ISO technical committees. Each member body interested in a subject for which a technical committee has been established has the right to be represented on that committee. International organizations, governmental and non-governmental, in liaison with ISO, also take part in the work. ISO collaborates closely with the International Electrotechnical Commission (IEC) on all matters of electrotechnical standardization.

International Standards are drafted in accordance with the rules given in the ISO/IEC Directives, Part 2.

The main task of technical committees is to prepare International Standards. Draft International Standards adopted by the technical committees are circulated to the member bodies for voting. Publication as an International Standard requires approval by at least 75 % of the member bodies casting a vote.

Attention is drawn to the possibility that some of the elements of this document may be the subject of patent rights. ISO shall not be held responsible for identifying any or all such patent rights.

Amendment 1 to ISO 1161:1984 was prepared by Technical Committee ISO/TC 104, *Freight containers*, Subcommittee SC 1, *General purpose containers*. The purpose of this amendment is to include 45 ft containers in ISO 1161:1984.

Series 1 freight containers — Corner fittings — Specification

AMENDMENT 1: 45 ft containers

Page 2, subclause 3.1.1

Add the following after paragraph 2:

Apart from the above, 45 ft containers shall have four top intermediate fittings in the 40 ft position [see Figures 1a) and 2a)] and four bottom intermediate fittings in the 40 ft position [see Figures 3a) and 4a)].

Page 2, subclause 3.2.4

Replace the first line by the following, to include “intermediate fittings”:

Where a corner or intermediate fitting has an optional inner side wall ...

Page 2, Clause 4 Strength requirements

Replace the first line by the following, to include “intermediate fittings”:

The corner or intermediate fittings shall ...

Page 2, 5.1 Loads

Replace the first paragraph by the following, to include “intermediate fittings”:

The following container design loads and criteria were used in establishing the dimensional design of corner or intermediate fittings specified in this International Standard.

Replace the second paragraph by the following, to include “intermediate fittings” and “1EEE and 1EE”:

Corner and intermediate fittings for series 1 freight containers shall be capable of withstanding the loads calculated in accordance with the requirements of ISO 1496-1 for 1AA, 1A, 1AX, 1EEE and 1EE containers.

Page 2, 5.1.1 Stacking

Replace “Top corner fitting [superimposed load offset ...]” by

Top corner or intermediate fitting [superimposed load offset ...]

Replace “Bottom corner fitting (resting on flat support)” by

Bottom corner or intermediate fitting (resting on flat support)

Replace “Bottom corner fitting [of No. 5 container offset ...]” by

Bottom corner or intermediate fitting [of No. 5 container offset ...]

Page 2, 5.1.2 Lifting

Replace “Top corner fitting [twistlock ...]” by

Top corner or intermediate fitting [twistlock ...]

Replace “Bottom corner fitting:” by

Bottom corner or intermediate fitting:

Replace the first line of the NOTES by:

Lifting from the bottom corner or intermediate fitting

Page 2, 5.1.3 Longitudinal restraint

Replace “Bottom corner fittings” by

Bottom corner or intermediate fittings

Page 2, 5.1.4 Lashing and securing

Replace by the following:

The force, or resultant of any combination of forces, imparted on the aperture in the end or the side of a corner or intermediate fitting as a result of the use of a lashing or a securing device, or a combination of such devices, is assumed not to exceed the value indicated by the point of the “envelope” shown in Figure 5 which is appropriate to the angle at which the force, or resultant force, is applied. It is further assumed that the force or resultant force lies in a plane parallel to and no more than 38 mm (1½ in) from the face of the corner or intermediate fitting.

Page 3, 5.1.5 Misgather

Replace by the following (to include “intermediate fittings”):

5.1.5 Misgather (localized loading of bottom corner or intermediate fittings caused by lowering of the container onto locating fittings which are not gathered in the hole).

Bottom corner or intermediate fittings shall be capable of withstanding a load of ...

Page 3, 5.2 Compulsory features

Replace by the following (to include “intermediate fittings”):

Compulsory walls or faces in the corner or intermediate fittings are:

Top corner or intermediate fittings: ...

Bottom corner or intermediate fittings: ...

Page 3, Clause 6 Minimum bearing area — Top corner fitting

Replace by the following (to include “intermediate fittings”):

6 Minimum bearing area — Top corner and intermediate fittings

It is assumed that lifting devices which only use the top apertures of the four top corner or intermediate fittings will have a minimum of total bearing area on the horizontal part of the inner top surfaces of the top corner or intermediate fittings of 800 mm^2 (1.24 in^2), for each of the top corner or intermediate fittings.

Page 3, Clause 7 Corner fitting marking (where provided)

Replace by the following (to include “intermediate fittings”):

7 Corner and intermediate fitting marking (where provided)

Marking on top and bottom corner and intermediate fittings shall be located at positions where they are clearly visible after assembly of the fittings to freight containers, and where they will not interfere with the satisfactory functioning of handling, locating and securing devices used in conjunction with the corner or intermediate fittings.

After page 8

Insert new Figures 1a), 2a), 3a), and 4a) as follows:

Dimensions in millimetres

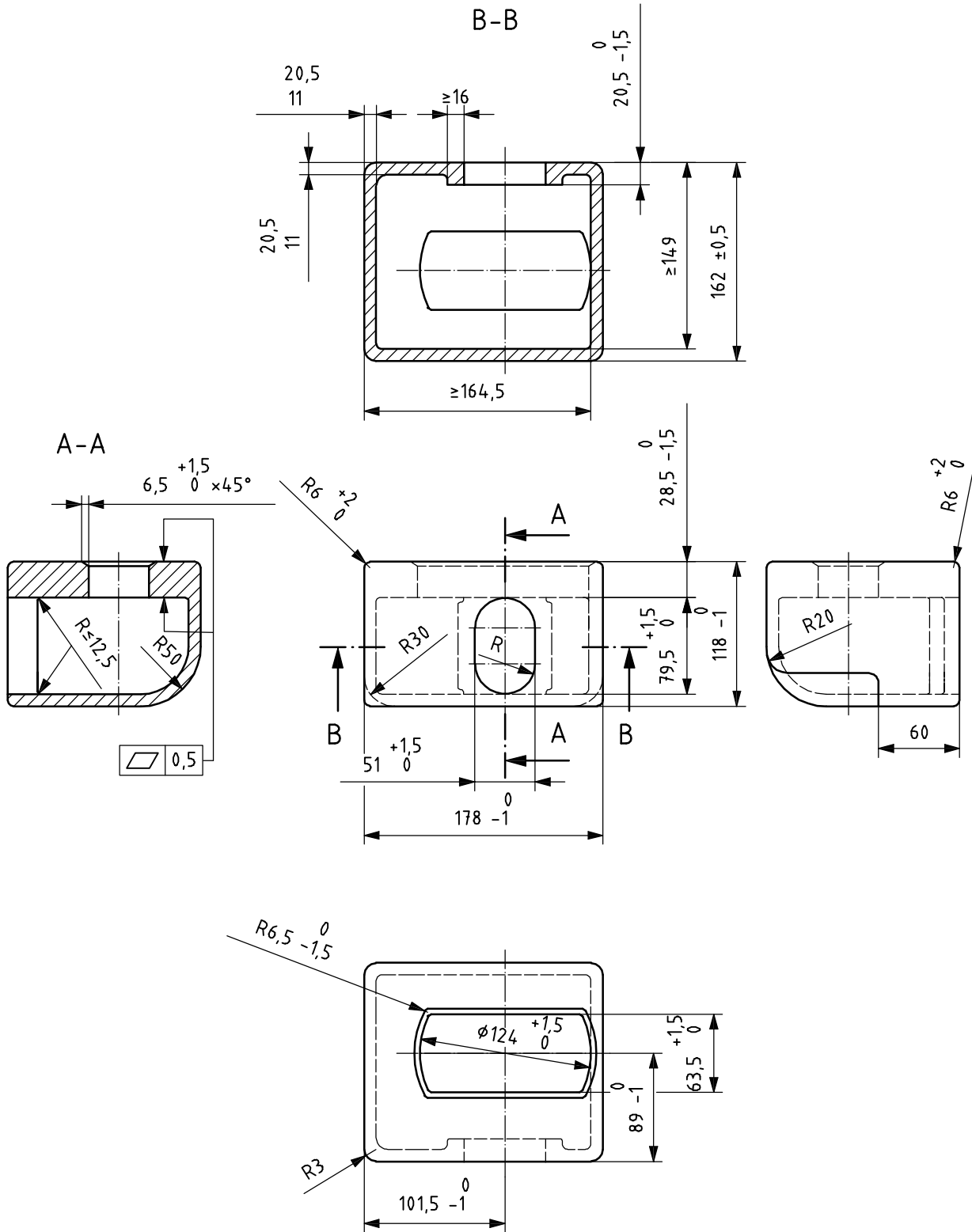

Figure 1a) — Top intermediate fitting — Dimensions in millimetres

Dimensions in inches

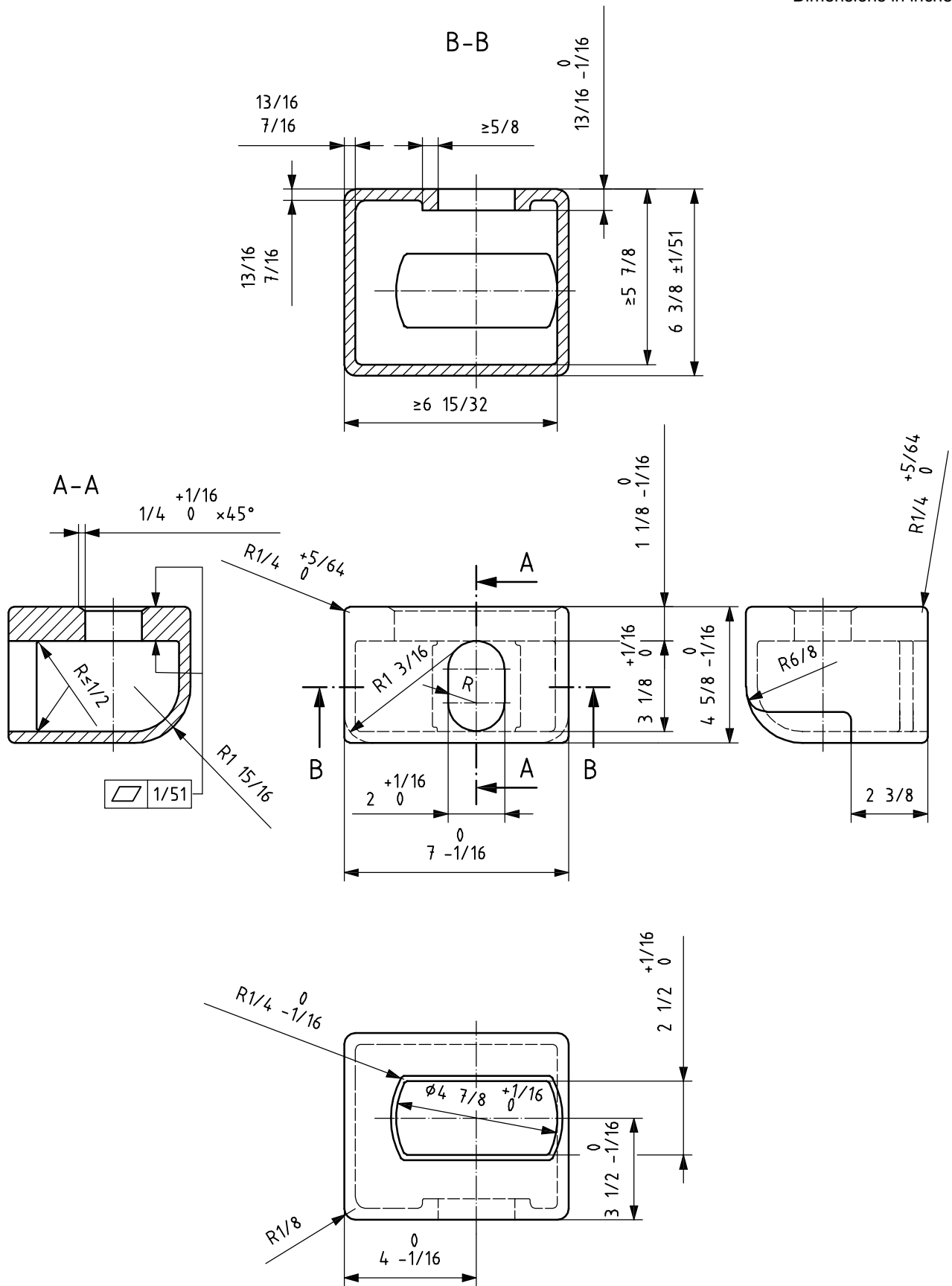

Figure 2a) — Top intermediate fitting — Dimensions in inches

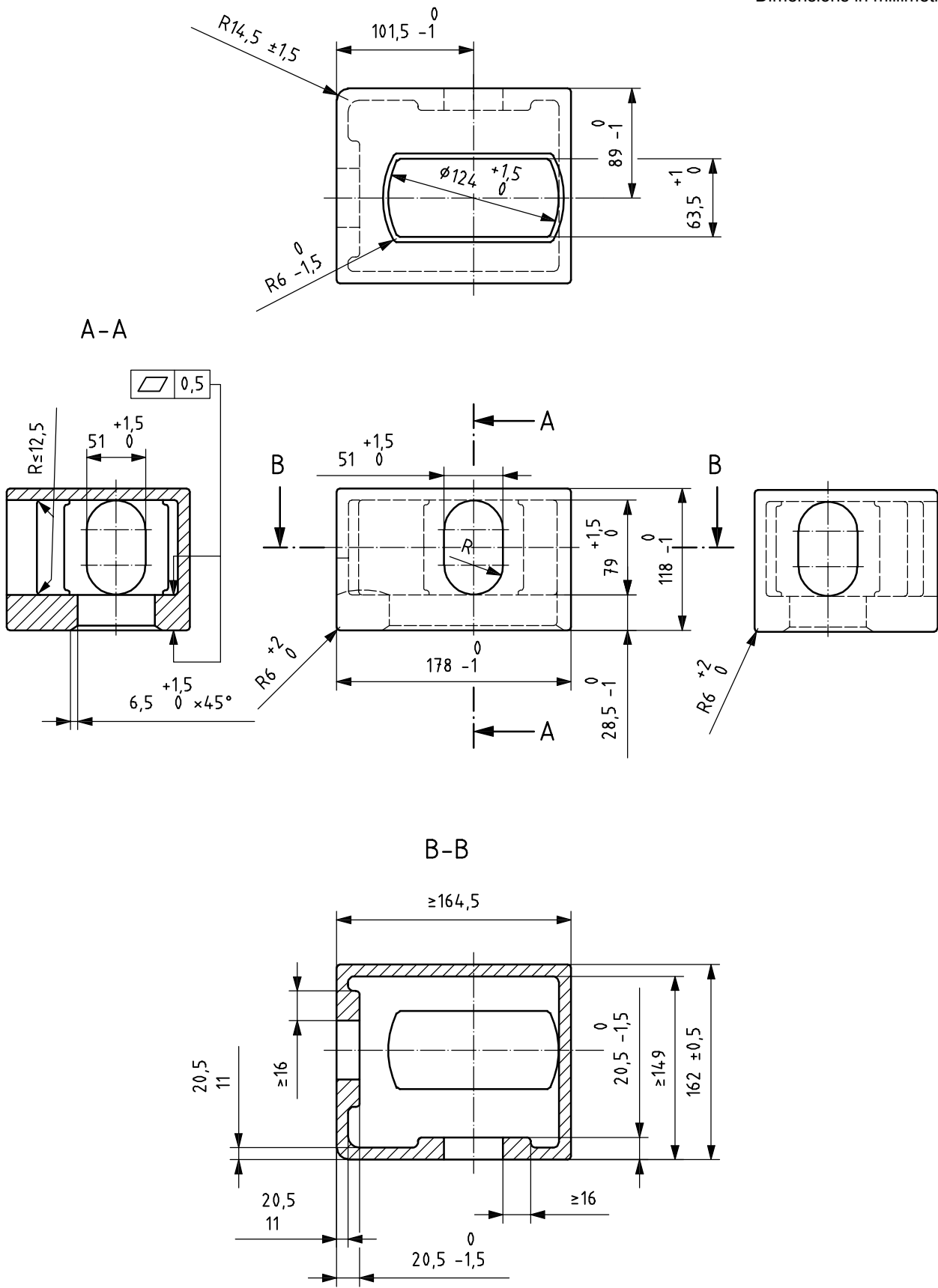

Figure 3a) — Bottom intermediate fitting — Dimensions in millimetres

Dimensions in inches

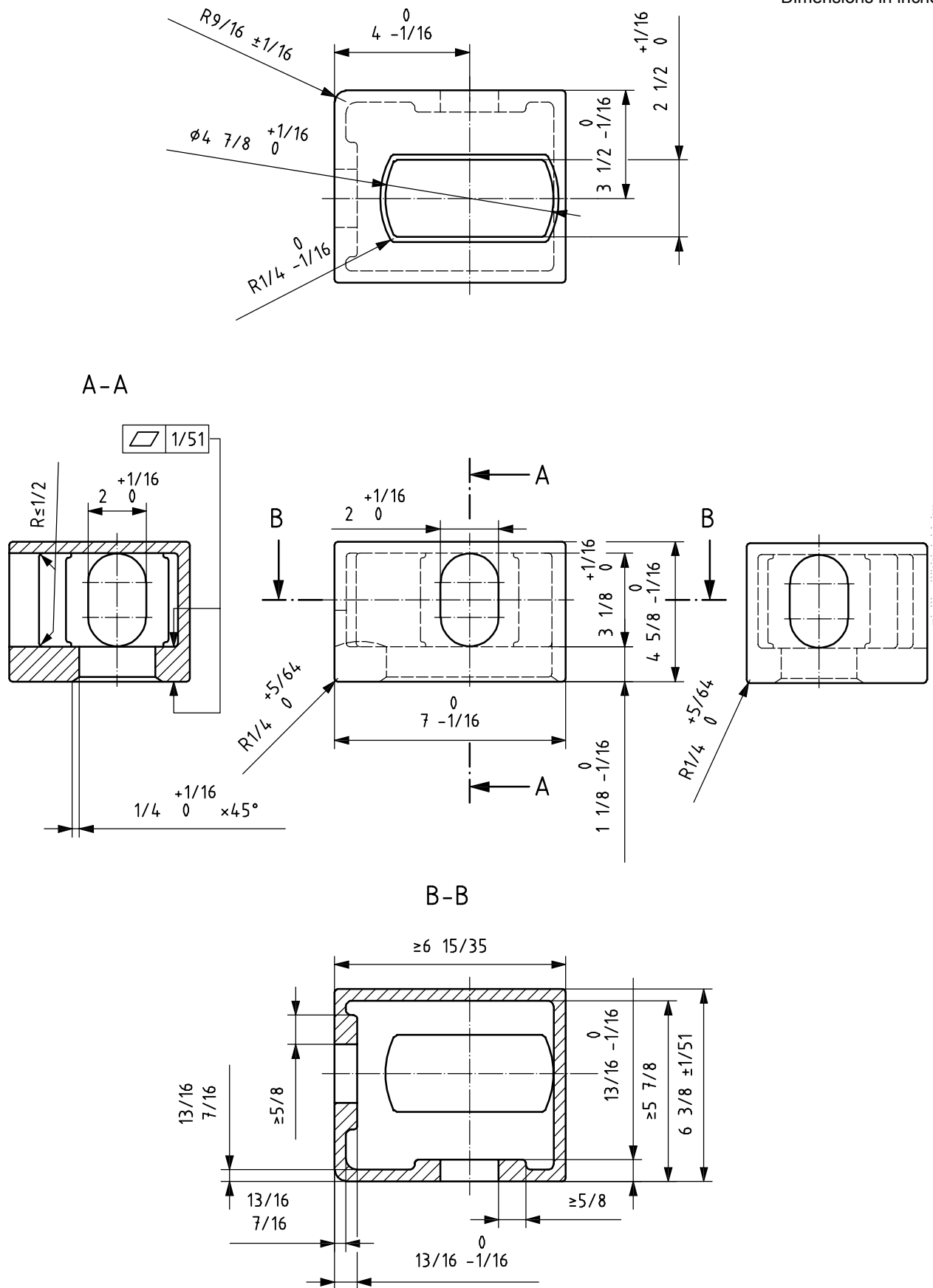

Figure 4a) — Bottom intermediate fitting — Dimensions in inches

Add the following as Figure 7 before Annex A:

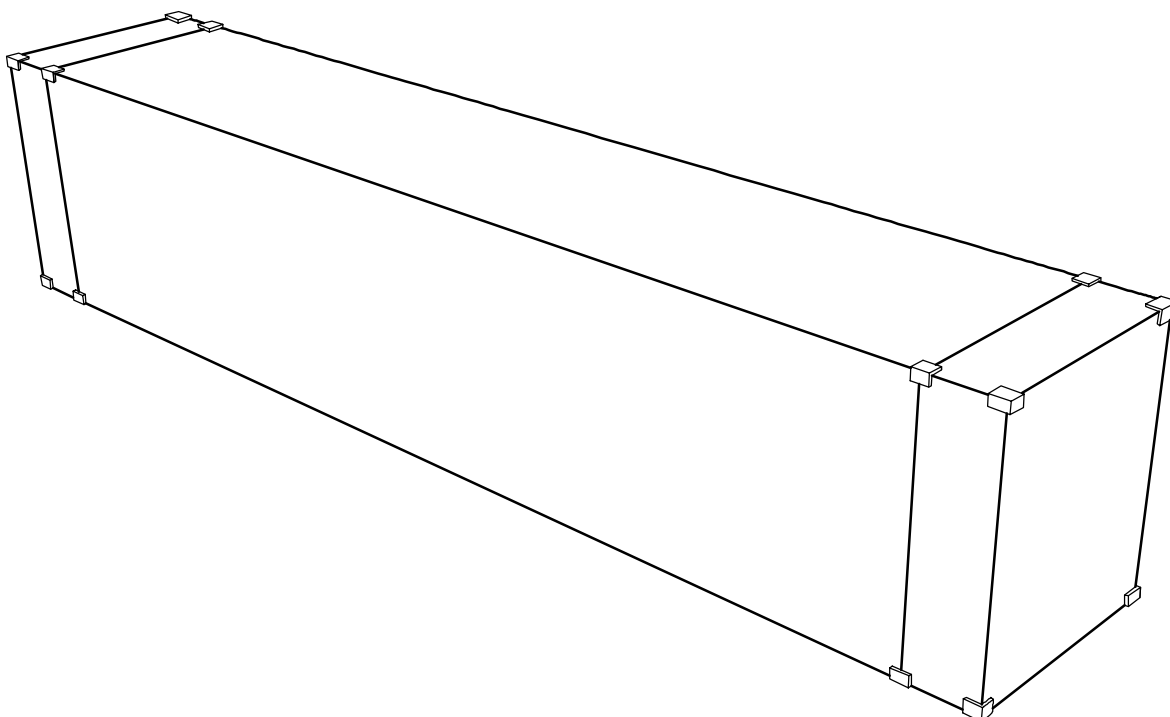

Figure 7 — 45 ft container with corner and intermediate fittings

Renumber the existing Figures 7 to 11 as Figures 8 to 12.

Page 14, Table 1

Add the following to Table 1, before row 1AA:

Table 1 — Normal centre-to centre distance for positioning of twistlock collars

1EEE/1EE	13 509,0	2 259,0
----------	----------	---------

Page 14, Table 2

Add the following to Table 2, before row 1AA (use the same tolerances as 1AA):

Table 2 — Tolerance ...

1EEE/1EE	± 2,5	± 3,5	± 4,5	± 2,0	± 3,0	± 4,0	4,5	8,5	10,5
----------	-------	-------	-------	-------	-------	-------	-----	-----	------

Page 15, Table 3

Add the following to Table 3, before row 1AA (use the same tolerances as 1AA)

Table 3 — “Practical” dimensions proposed by the USA ...

1EEE/1EE	± 4,5	± 2,5	7,0	± 6,0	$\begin{matrix} +0 \\ -3 \end{matrix}$	16
----------	-------	-------	-----	-------	--	----

Page 20, Table 5

Add the following to Table 5, before row 1AA (use the same tolerances as 1AA):

Table 5 — Basic data ...

1EEE/1EE	11 985,5	± 6,5	2 259,0	± 4,0	19	9,7	1,96
----------	----------	-------	---------	-------	----	-----	------

Page 20, Table 6

Add the following to Table 6, before row 1AA (use the same tolerances as 1AA):

Table 6 — Twistlock collars (spigots) having length (diameter) 95,0 mm ...

1EEE/1EE	9,8	4,0	5,8	11,5	4,0
		4,5	5,3	10,5	4,0
		5,0	4,8	9,5	4,0

Page 20, Table 7

Add the following to Table 7, before row 1AA (use the same tolerances as 1AA):

Table 7 — Twistlock collars (spigots) having length (diameter) 97,0 mm ...

1EEE/1EE	7,8	3,0	4,8	9,5	3,0
		3,5	4,3	8,5	3,0
		4,0	3,8	7,5	3,0

Page 21, Table 8

Add the following to Table 8, before row 1AA (use the same tolerances as 1AA):

Table 8 — Twistlock collars (spigots) having length (diameter) 100,0 mm ...

1EEE/1EE	4,8	2,0	2,8	5,5	3,0
		2,5	2,3	4,5	3,0
		3,0	1,8	3,5	3,0

ICS 55.180.10

Price based on 9 pages