**Metallic materials — Rotating bar bending
fatigue testing**

*Matériaux métalliques — Essais de fatigue par flexion rotative de
barreaux*



Reference number
ISO 1143:2010(E)

© ISO 2010

PDF disclaimer

This PDF file may contain embedded typefaces. In accordance with Adobe's licensing policy, this file may be printed or viewed but shall not be edited unless the typefaces which are embedded are licensed to and installed on the computer performing the editing. In downloading this file, parties accept therein the responsibility of not infringing Adobe's licensing policy. The ISO Central Secretariat accepts no liability in this area.

Adobe is a trademark of Adobe Systems Incorporated.

Details of the software products used to create this PDF file can be found in the General Info relative to the file; the PDF-creation parameters were optimized for printing. Every care has been taken to ensure that the file is suitable for use by ISO member bodies. In the unlikely event that a problem relating to it is found, please inform the Central Secretariat at the address given below.



COPYRIGHT PROTECTED DOCUMENT

© ISO 2010

All rights reserved. Unless otherwise specified, no part of this publication may be reproduced or utilized in any form or by any means, electronic or mechanical, including photocopying and microfilm, without permission in writing from either ISO at the address below or ISO's member body in the country of the requester.

ISO copyright office
Case postale 56 • CH-1211 Geneva 20
Tel. + 41 22 749 01 11
Fax + 41 22 749 09 47
E-mail copyright@iso.org
Web www.iso.org

Published in Switzerland

Contents

Page

Foreword	iv
1 Scope	1
2 Normative references	1
3 Terms and definitions	1
4 Symbols and designations	2
5 Principle of test.....	2
6 Shape and size of specimen	3
6.1 Forms of the test section	3
6.2 Dimensions of specimens	3
7 Preparation of specimens.....	4
7.1 General	4
7.2 Selection of the specimen	4
7.3 Machining procedure	4
7.4 Sampling and marking	5
7.5 Storage and handling.....	6
8 Accuracy of the testing apparatus	6
9 Heating device and temperature measurement	6
10 Test procedure.....	6
10.1 Mounting the specimen	6
10.2 Application of force.....	7
10.3 Frequency selection	8
10.4 End of test	8
10.5 Procedure for testing at elevated temperature	8
10.6 Construction of the <i>S-N</i> diagram.....	9
11 Presentation of fatigue test results	9
11.1 Tabular presentation.....	9
11.2 Graphical presentation	10
12 Test report.....	10
Annex A (normative) Verification of the bending moment of rotating bar bending fatigue machines	17
Bibliography.....	26

Foreword

ISO (the International Organization for Standardization) is a worldwide federation of national standards bodies (ISO member bodies). The work of preparing International Standards is normally carried out through ISO technical committees. Each member body interested in a subject for which a technical committee has been established has the right to be represented on that committee. International organizations, governmental and non-governmental, in liaison with ISO, also take part in the work. ISO collaborates closely with the International Electrotechnical Commission (IEC) on all matters of electrotechnical standardization.

International Standards are drafted in accordance with the rules given in the ISO/IEC Directives, Part 2.

The main task of technical committees is to prepare International Standards. Draft International Standards adopted by the technical committees are circulated to the member bodies for voting. Publication as an International Standard requires approval by at least 75 % of the member bodies casting a vote.

Attention is drawn to the possibility that some of the elements of this document may be the subject of patent rights. ISO shall not be held responsible for identifying any or all such patent rights.

ISO 1143 was prepared by Technical Committee ISO/TC 164, *Mechanical testing of metals*, Subcommittee SC 5, *Fatigue testing*.

This second edition cancels and replaces the first edition (ISO 1143:1975), which has been technically revised.

Metallic materials — Rotating bar bending fatigue testing

1 Scope

This International Standard specifies the method for rotating bar bending fatigue testing of metallic materials. The tests are conducted at room temperature or elevated temperature in air, the specimen being rotated.

2 Normative references

The following referenced documents are indispensable for the application of this document. For dated references, only the edition cited applies. For undated references, the latest edition of the referenced document (including any amendments) applies.

ISO 376, *Metallic materials — Calibration of force-proving instruments used for the verification of uniaxial testing machines*

ISO 1099, *Metallic materials — Fatigue testing — Axial force-controlled method*

ISO 12106, *Metallic materials — Fatigue testing — Axial-strain-controlled method*

ISO 12107, *Metallic materials — Fatigue testing — Statistical planning and analysis of data*

ISO 23718, *Metallic materials — Mechanical testing — Vocabulary*

3 Terms and definitions

For the purposes of this document, the terms and definitions given in ISO 1099, ISO 12106, ISO 12107, ISO 23718 and the following apply.

3.1

fatigue

process of changes in properties which can occur in a metallic material due to the repeated application of stresses or strains and which can lead to cracking or failure

3.2

fatigue life

N_f

number of cycles of a specified character that a given specimen sustains before failure of a specified nature occurs

3.3

***S-N* diagram**

diagram that shows the relationship between stress and fatigue life

3.4

bending moment

M

multiplication between force and force arm length

3.5
section modulus

W
ratio of the moment of inertia of the cross-section of a beam undergoing flexure to the greatest distance of an element of the beam from the neutral axis

3.6
machine lever ratio

M_{lr}
ratio between the force applied to the weight hanger and the force applied to the specimen

3.7
force arm length

L
distance between the supporting point and the loading point

See Figures 1 to 7.

NOTE L_1 should equal L_2 for the four-point loading condition.

3.8
endurance stress limit

fatigue limit
cyclic stress range applied to specimens that do not fail upon application of a given number of cycles

NOTE 1 The cycle number limit selected, e.g. 10^7 or 10^8 cycles, shall be specified along with the stress range.

NOTE 2 For a specified fatigue life, “endurance stress limit” has been supplanted by “fatigue limit” as the preferred term.

4 Symbols and designations

Symbols and corresponding designations are given in Table 1, or elsewhere in this International Standard where they appear.

Table 1 — Symbols and designations

Symbol	Designation	Unit
D	Diameter of gripped or loaded end of specimen	mm
d	Diameter of specimen where stress is maximum	mm
N_f	Fatigue life, cycles to failure	cycle
r	Radius at ends of test section which starts transition from test diameter, d	mm

5 Principle of test

Nominally identical specimens are used, each being rotated and subjected to a bending moment. The forces giving rise to the bending moment do not rotate. The specimen may be mounted as a cantilever, with single-point or two-point loading, or as a beam, with four-point loading. The test is continued until the specimen fails or until a pre-determined number of stress cycles have been achieved.

6 Shape and size of specimen

6.1 Forms of the test section

The test section may be

- a) cylindrical, with tangentially blending fillets at one or both ends (see Figures 1, 4 and 5),
- b) tapered (see Figure 2), or
- c) hourglass-type (see Figures 3, 6 and 7).

In each case, the test section shall be of circular cross-section.

The form of test section may be dependent on the type of loading to be employed. While cylindrical or hourglass-type specimens may be loaded as beams, or as cantilevers with either single-point or double-point loading, the tapered form of specimen is used only as a cantilever with single-point loading. Figures 1 to 7 show, in schematic form, the bending moment and nominal stress diagrams for the various practical cases.

The volumes of material subjected to greatest stresses are not the same for different forms of specimen, and they may not necessarily give identical results. The test in which the largest volume of material is highly stressed is preferred.

Experience has shown that a ratio of at least 3:1 between the cross-sectional areas of the test portion and the gripping regions of the specimen is desirable.

In tests on certain materials, a combination of high stress and high speed may cause excessive hysteresis heating of the specimen. This effect may be reduced by subjecting a smaller volume of the material to the specified stress. If the specimen is cooled, the test medium should be reported.

6.2 Dimensions of specimens

All the specimens employed in a test series for a fatigue-life determination shall have the same size, shape and tolerance of diameter.

For the purpose of calculating the force to be applied to obtain the required stress, the actual minimum diameter of each specimen shall be measured to an accuracy of 0,01 mm. Care shall be taken during the measurement of the specimen prior to testing to ensure that the surface is not damaged.

On cylindrical specimens subject to constant bending moment (see Figures 4 and 5), the parallel test section shall be parallel within 0,025 mm. For other forms of cylindrical specimen (see Figure 1), the parallel test section shall be parallel within 0,05 mm. For material property determination, the transition fillets at the ends of the test section should have a radius not less than $3d$. For hourglass-type specimens, the section formed by the continuous radius should have a radius not less than $5d$.

Figure 8 shows the shape and dimensions of a typical cylindrical specimen. The recommended values of d are 6 mm, 7,5 mm and 9,5 mm. The tolerance of diameter should be $\leq 0,005d$. Figure 9 shows a typical hourglass specimen suitable for fatigue testing at elevated temperature.

Fatigue tests on notched specimens are not covered by this International Standard, since the shape and size of notched specimens have not been standardized. However, fatigue test procedures described in this International Standard may be applied to fatigue tests of notched specimens.

7 Preparation of specimens

7.1 General

In any rotating bar bending fatigue test programme designed to characterize the intrinsic properties of a material, it is important to observe the following recommendations in the preparation of specimens. A possible reason for deviation from these recommendations is if the test programme aims to determine the influence of a specific factor (surface treatment, oxidation, etc.) that is incompatible with the recommendations. In all cases, any deviation shall be noted in the test report.

7.2 Selection of the specimen

The location, orientation and type of specimen shall be taken from the related product standard, or by agreement with the customer.

The sampling of test materials from a semi-finished product or a component may have a major influence on the results obtained during the test. It is therefore necessary for this sampling to be recorded and a sampling drawing be prepared. This shall form part of the test report and shall indicate clearly

- the position of each of the specimens removed from the semi-finished product or component,
- the characteristic directions in which the semi-finished product has been worked (direction of rolling, extrusion, etc., as appropriate), and
- the unique identification of each of the specimens.

The unique mark or identification of each specimen shall be maintained at each stage of its preparation. This may be applied using any reliable method in an area not likely to disappear during machining or likely to adversely affect the quality of the test. Upon completion of the machining process, it is desirable for both ends of each specimen to be uniquely marked so that, after failure of a specimen, each half can still be identified.

7.3 Machining procedure

7.3.1 Heat treatment of test material

If heat treatment is to be carried out after rough finishing of the specimens, it is preferable that the final polishing be carried out after the heat treatment. If that is not possible, the heat treatment should be carried out in a vacuum or in inert gas to prevent oxidation of the specimen. Stress relief is recommended in this case. This treatment shall not alter the micro-structural characteristic of the material under study. The specifics of the heat treatment and machining procedure shall be reported with the test results.

7.3.2 Machining criteria

The machining procedure selected may produce residual stresses on the specimen surface likely to affect the test results. These stresses may be induced by heat gradients at the machining stage or they may be associated with deformation of the material or micro-structural alterations. Their influence is less marked in tests at elevated temperatures because they are partially or totally relaxed once the temperature is attained. However, they should be reduced by using an appropriate final machining procedure, especially prior to a final polishing stage. For harder materials, grinding rather than turning or milling may be preferred.

- Grinding: from 0,1 mm above the final diameter, at a rate of no more than 0,005 mm/pass.
- Polishing: remove the final 0,025 mm with abrasives of decreasing grit size. The final direction of polishing shall be along the test specimen axis.

The phenomenon of alteration in the microstructure of the material may be caused by the increase in temperature and by the strain hardening induced by machining. It may be a matter of a change in phase or,

more frequently, of surface re-crystallization. The immediate effect of this is to make the test specimen no longer representative of the initial material. Hence, every precaution should therefore be taken to avoid this risk.

Contaminants can be introduced when the mechanical properties of certain materials deteriorate in the presence of certain elements or compounds. An example of this is the effect of chlorine on steels and titanium alloys. These elements should therefore be avoided in the products used (cutting fluids, etc.). Rinsing and degreasing of specimens prior to storage is also recommended.

7.3.3 Inspection of specimens

The surface condition of specimens has an effect on the test results. This effect is generally associated with one or more of the following factors:

- the specimen surface roughness;
- the presence of residual stresses;
- alteration in the microstructure of the material;
- the introduction of contaminants.

The recommendations below allow the influence of these factors to be reduced to a minimum.

The surface condition is commonly quantified by the mean roughness or equivalent (e.g. 10 point roughness or maximum height of irregularities). The importance of this variable on the results obtained depends largely on the test conditions, and its influence is reduced by surface corrosion of the specimen or plastic deformation.

It is preferable, whatever the test conditions, to specify a mean surface roughness, R_z , of less than $0,2 \mu\text{m}$ (or equivalent).

Another important parameter not covered by mean roughness is the presence of localized machining scratches. A low-magnification check (at approximately $\times 20$) shall not show any circumferential scratches or abnormalities.

7.3.4 Dimensional checks

The diameter shall be measured on each specimen. In the case of specimens with a parallel gauge length, the diameter shall be measured at a minimum of three positions along the gauge length. The measurement shall be performed using a method that does not damage the specimen.

7.4 Sampling and marking

The sampling of test materials from a semi-finished product or a component may have a major influence on the results obtained during the test. It is therefore necessary for this sampling to be recorded and a sampling drawing to be prepared. This shall form part of the test report and shall indicate clearly

- the position of each of the specimens removed from the semi-finished product or component,
- the characteristic directions in which the semi-finished product has been worked (direction of rolling, extrusion, etc., as appropriate), and
- the unique identification of each of the specimens.

The unique mark or identification of each specimen shall be maintained at each stage of their preparation. This may be applied using any reliable method in an area not likely to disappear during machining or likely to adversely affect the quality of the test. Upon completion of the machining process, it is desirable for both ends of each specimen to be uniquely marked so that, after failure of a specimen, each half can still be identified.

7.5 Storage and handling

After preparation, the specimens shall be stored so as to prevent any risk of damage (scratching by contact, oxidation, etc.). The use of individual boxes or tubes with end caps is recommended. In certain cases, storage in a vacuum or in a desiccator containing silica gel may be necessary.

Handling shall be reduced to the minimum necessary. In all instances, the gage length or test section should not be touched. However, if this happens, cleaning the specimen with alcohol is allowed.

8 Accuracy of the testing apparatus

A number of different types of rotating bending fatigue machine are used. Figures 1 to 7 show the principles of the main types of machine. Figure 11 shows the schematic of a kind of rotating bend fatigue machine. Its operation shall satisfy the following requirement: the accuracy of the applied bending moment shall be within 1% (see Annex A).

9 Heating device and temperature measurement

9.1 The specimen is heated with a furnace or equivalent device.

9.2 The temperature of the furnace shall be kept uniform throughout the test, complying with the limits defined in 10.5.3. The temperature gradient along the test section of the specimen in the furnace shall not be greater than 15 °C.

9.3 To measure or record temperature, the thermocouple, compensating wire, and controlling and measuring temperature meter that are used shall be calibrated together as a system. The calibration interval shall be in accordance with the product standard, customer requirements and good metrological practice.

9.4 The temperature indicator shall have a resolution of at least 0,5 °C and the temperature measuring equipment shall have an accuracy of ± 1 °C.

10 Test procedure

10.1 Mounting the specimen

Each specimen shall be mounted in the test machine such that stresses at the test section (other than those imposed by the applied force) are avoided. If the bearings transmitting the force are secured to the specimen by means of split collets, in certain cases it may be desirable for these to be positioned and fully tightened before the specimen is mounted in the test machine, in order to prevent an initial torsion strain being imparted. A similar practice may be necessary if the method of securing is by means of an interference fit.

To avoid vibration during the test, alignment of the specimen and the driving shaft of the test machine shall be maintained within close limits. Permissible tolerances are $\pm 0,025$ mm at the chuck end and $\pm 0,013$ mm at the free end for single-point and some types of two-point loading test machines. For other types of rotating bending fatigue test machines, the permissible tolerance on eccentricity measured at two places along the actual test section is no greater than $\pm 0,013$ mm. The required degree of alignment shall be established before applying any force.

NOTE These measurements are typically made using a dial gauge.

10.2 Application of force

The lever ratio shall be calibrated according to Annex A. The test stress is calculated according to Table 2.

Table 2 — Derivation of weight to be applied to test machine loading system

Machine type	Loading system	S	F	Conversion of F to applied mass
Single-point bending	Direct load	$S = \frac{M}{W} = \frac{16F(L-x)}{\pi d^3}$	$F = S \frac{\pi d^3}{16(L-x)}$	$\times 1,0$
Single-point bending	Fixed ratio lever	$S = \frac{M}{W} = \frac{16F(L-x)}{\pi d^3}$	$F = S \frac{\pi d^3}{16(L-x)}$	Divide by the lever ratio, M_{lr} .
Single-point bending	Lever and poise	$S = \frac{M}{W} = \frac{16F(L-x)}{\pi d^3}$	$F = S \frac{\pi d^3}{16(L-x)}$	Set to F on the load scale on the lever.
Two-point bending	Direct load	$S = \frac{M}{W} = \frac{16FL}{\pi d^3}$	$F = S \frac{\pi d^3}{16L}$	$\times 1,0$
Two-point bending	Fixed ratio lever	$S = \frac{M}{W} = \frac{16FL}{\pi d^3}$	$F = S \frac{\pi d^3}{16L}$	Divide by the lever ratio, M_{lr} .
Two-point bending	Lever and poise	$S = \frac{M}{W} = \frac{16FL}{\pi d^3}$	$F = S \frac{\pi d^3}{16L}$	Set to F on the load scale on the lever.
Four-point bending	Direct load	$S = \frac{M}{W} = \frac{32FL}{\pi d^3}$	$F = S \frac{\pi d^3}{32L}$	$\times 1,0$
Four-point bending	Fixed ratio lever	$S = \frac{M}{W} = \frac{32FL}{\pi d^3}$	$F = S \frac{\pi d^3}{32L}$	Divide by the lever ratio, M_{lr} .
Four-point bending	Lever and poise	$S = \frac{M}{W} = \frac{32FL}{\pi d^3}$	$F = S \frac{\pi d^3}{32L}$	Set to F on the load scale on the lever.

where

- S is the required test stress;
- M is the bending moment;
- F is the applied force;
- L is the force arm length (see A.4.2);
- d is the specimen diameter;
- W is the section modulus;
- M_{lr} is the machine lever ratio (see also A.4.3);
- x is the distance along the specimen axis from the fixed bearing face to the stress measurement plane.

The general procedure for attaining full-force running conditions shall be the same for each specimen. The test machine shall be switched “ON” and the desired speed attained before application of force is commenced. The force shall then be applied incrementally or continuously until the required value is attained, without shock or impact, and as quickly as is convenient. Small adjustments in operating speed can then be made if a particular frequency is required.¹⁾

10.3 Frequency selection

The frequency chosen shall be suitable for the particular combination of material, specimen and test machine. The testing speed should be the same for the given test series. It is necessary to avoid abnormal vibration of the specimen when testing.

Tests are normally performed at a frequency between 15 to 200 Hz (i.e. from 900 to 12 000 rev/min).

At high frequencies, self-heating of the specimen can occur and could affect the resulting fatigue life. If self-heating occurs, it is advisable to decrease the test frequency. In room temperature testing, self-heating of the specimen should be monitored and recorded. The specimen temperature, T_H , in Kelvin (K), should not exceed:

$$0,3T_H = \frac{T_{\text{test}}}{T_{\text{melt}}}$$

NOTE If the influence of the environment is significant, the test result is likely to be frequency-dependent.

10.4 End of test

The test is continued until specimen failure or until it has reached the required number of cycles (e.g. 10^7 or 10^8). Where the failure location is outside the specimen gauge length, the test result is considered invalid.

10.5 Procedure for testing at elevated temperature

10.5.1 Due to the nature of rotating bar bending fatigue testing, direct temperature measurement may not be possible. If this is the case, it is essential to use indirect temperature measurement, calibrated in a static manner.

10.5.2 To measure the temperature of the specimen two approaches are possible.

The first approach, which is the preferred method, uses indirect measurement, i.e. the tip of the thermocouple is not directly in contact with the specimen surface, but kept about 1-2 mm distance from it. When using this method, the laboratory shall establish a relationship between the specimen surface temperature and that shown by the measuring thermocouple. This relationship shall be used to derive a correction factor for establishing the specimen temperature.

The second approach uses direct measurement, i.e. the thermocouple tip is directly in contact with the specimen surface. Use of this approach requires the test machine to be stopped periodically, the load to be removed and then the temperature of the specimen surface to be measured.

NOTE Self-heating of the specimen is not considered in this procedure.

1) It is recognized that plasticity is present in the low-cycle region. For details, see Reference [2], Chapter 7 and references thereto.

10.5.3 The specimen shall be heated to the specified temperature and stabilized for approximately half an hour prior to starting the test. During the entire test cycle, the fluctuation in the indicated specimen temperature shall be within the following specified limits:

Test temperature	Permissible temperature fluctuation
≤ 600 °C	± 3 °C
600–900 °C	± 4 °C
900–1 200 °C	± 6 °C

The temperature (gradient) on the testing section of the specimen in the furnace body length shall not be greater than 15 °C.

Establishing the gradient along the specimen gauge length is typically machine-specific. One approach is to use a specimen with three thermocouples along the gauge length, inserted into the test machine. The furnace and associated control/monitoring thermocouples are installed and the furnace heated to the test temperature. When the furnace has stabilized at the required temperature, the temperatures are measured and a gradient derived.

10.5.4 The temperature-measuring device should be stable within ± 1 °C over all changes in ambient temperature.

During the test, if there is a significant decrease in the furnace temperature for a short time (i.e. $<10\%$ N_f), these cycle numbers may be deducted from the total cycle numbers. If the control temperature exceeds the specified temperature (i.e. $>10\%$ N_f) and specimen fracture occurs or other abnormal phenomenon, this result may be considered as invalid.

10.6 Construction of the *S-N* diagram

The predetermined number of cycles at which a test is discontinued will generally depend on the material being tested. The *S-N* curve for certain materials shows a distinct change in slope in a given number of cycles such that the latter part of the curve is essentially parallel to the horizontal axis. With other materials, the shape of the *S-N* curve may be a continuously decreasing slope that will eventually become asymptotic to the horizontal axis. Where *S-N* curves of the first type are experienced, it is recommended that the “endurance” stress limit that is used as a basis be at 10^7 cycles and, for the second type, 10^8 cycles. For guidance in planning a fatigue test, see ISO 12107. The specified number of cycles (e.g. 10^7 or 10^8) shall be included with the determined “endurance” stress limit range.

NOTE Commonly employed “endurances” are, for example: 10^7 cycles for structural steels and 10^8 cycles for other steels and non-ferrous alloys. In light of recent research, however, it is of importance to note that metals generally *do not* exhibit an endurance stress limit or fatigue limit per se, i.e. a stress below which the metal will endure an “infinite number of cycles.” Typically, the “plateau(s)” in stress-life are referred to as the convenient fatigue limit(s) or endurance limit(s), but failures below these levels have been reported and do occur.

11 Presentation of fatigue test results

11.1 Tabular presentation

It is desirable but not required that the fatigue test results be reported in tabular form. When used, the tabular presentation shall include, at minimum, the specimen identification, test sequence, testing stress range, fatigue life or cycles to end of test.

11.2 Graphical presentation

The most common graphical presentation of fatigue test data is the S - N (stress-life) diagram (see Figure 10). The dependent variable, fatigue life, N , in cycles, is plotted on the abscissa as a logarithmic scale. The independent variable, maximum stress, S_{\max} , stress range, S_r , or stress amplitude, S_a , expressed in megapascals (MPa) is plotted on the ordinate, an arithmetic or logarithmic scale. A best-fit curve is fitted by regression analysis or similar mathematical techniques to the fatigue data. The procedure described above develops the S - N diagram for 50 % survival when the logarithms of the lives are described by a normal distribution. However, similar procedures may be used to develop S - N diagrams for probabilities of survival other than 50 % (e.g. 5 and 95 %).

Minimum information to be presented on the S - N diagram should include the designation, specification or proprietary, grade of the material, tensile strength, surface condition of specimen, stress concentration factor of notch when applicable, type of fatigue test, test frequency, environment and test temperature.

12 Test report

In reporting fatigue data, the test conditions shall be defined clearly and the test report shall include details of the following items:

- a) material tested and its metallurgical characteristics — reference can usually be made to the appropriate International Standard to which the material was produced;
- b) method of stressing and the type of machine used;
- c) type, dimensions and surface condition of the specimen and the points of load application;
- d) frequency of the stress cycles;
- e) test temperatures and the temperature of the specimen if self-heating occurs (i.e. greater than 35 °C);
- f) daily maximum and minimum values of air temperature and relative humidity;
- g) criterion for the end of the test, i.e. its duration (e.g. 10^6 , 10^7 , 10^8 cycles), or complete failure of the specimen, or some other criterion;
- h) any deviations from the required conditions during the test;
- i) test result.

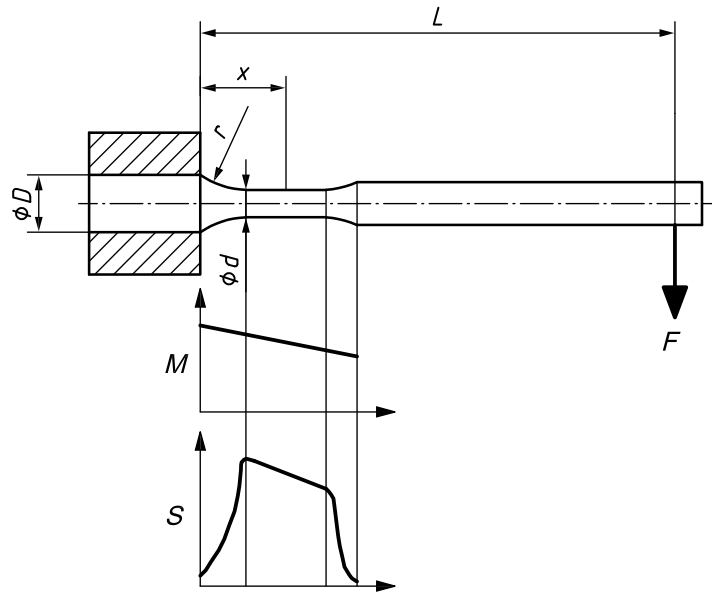

Key

- | | | | |
|-----|---|-----|--|
| D | diameter of gripped or loaded end of specimen | M | bending moment |
| d | diameter of specimen where stress is maximum | r | radius (see Table 1) |
| F | applied force | S | stress |
| L | force arm length | x | distance along specimen axis from fixed bearing face to stress measurement plane |

Figure 1 — Parallel specimen — Single-point loading

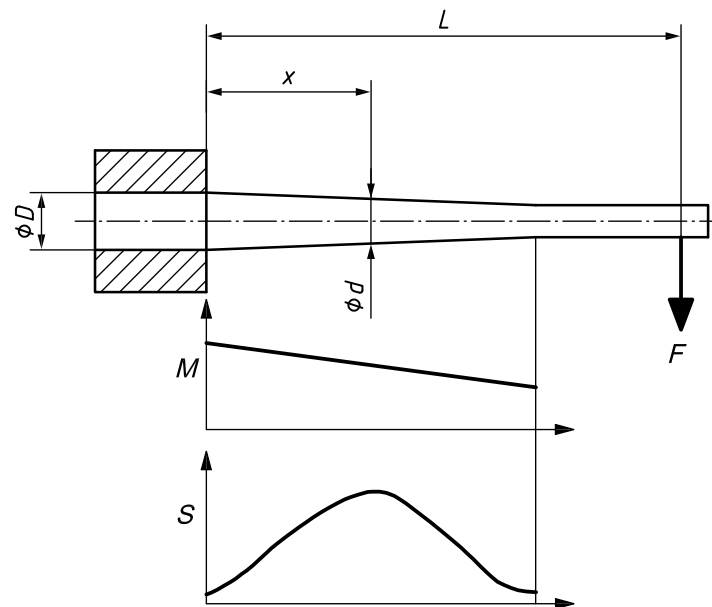

Key

- | | | | |
|-----|---|-----|--|
| D | diameter of gripped or loaded end of specimen | M | bending moment |
| d | diameter of specimen where stress is maximum | S | stress |
| F | applied force | x | distance along specimen axis from fixed bearing face to stress measurement plane |
| L | force arm length | | |

Figure 2 — Tapered specimen — Single-point loading

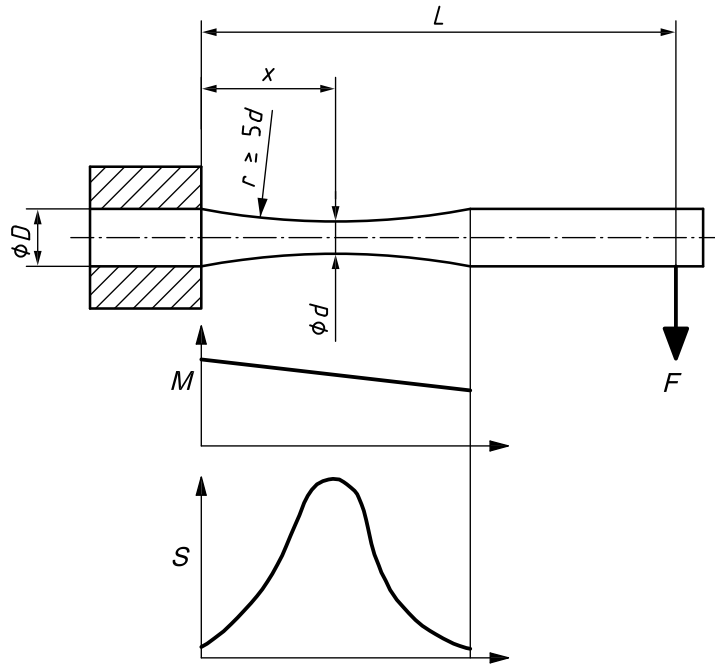

Key

- | | | | |
|-----|---|-----|--|
| D | diameter of gripped or loaded end of specimen | M | bending moment |
| d | diameter of specimen where stress is maximum | S | stress |
| F | applied force | x | distance along specimen axis from fixed bearing face to stress measurement plane |
| L | force arm length | | |

Figure 3 — Hourglass specimen — Single-point loading

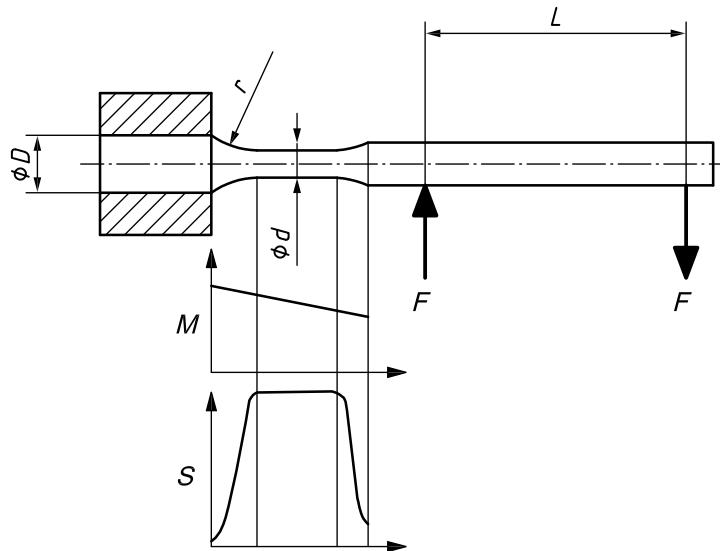

Key

- | | | | |
|-----|---|-----|----------------------|
| D | diameter of gripped or loaded end of specimen | M | bending moment |
| d | diameter of specimen where stress is maximum | r | radius (see Table 1) |
| F | applied force | S | stress |
| L | force arm length | | |

Figure 4 — Parallel specimen — Two-point loading

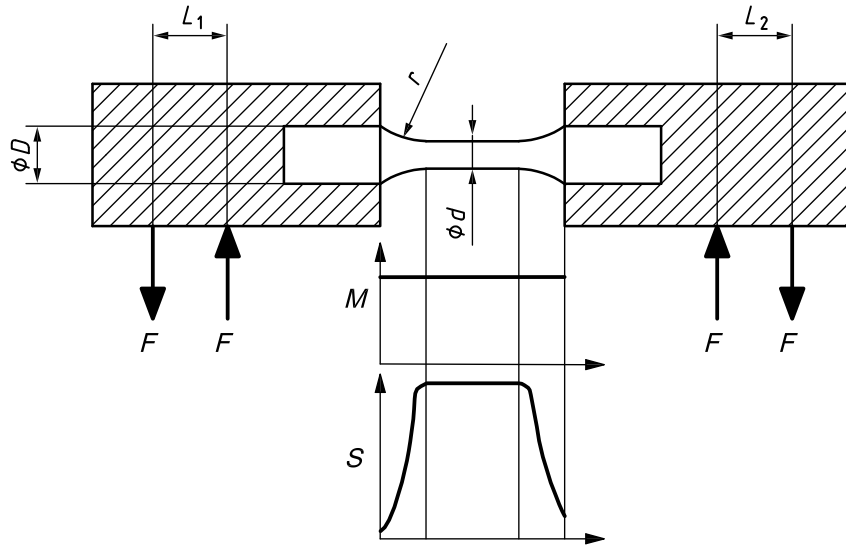

Key

- | | | | |
|------------|---|-----|----------------------|
| D | diameter of gripped or loaded end of specimen | M | bending moment |
| d | diameter of specimen where stress is maximum | r | radius (see Table 1) |
| F | applied force | S | stress |
| L_1, L_2 | force arm lengths | | |

Figure 5 — Parallel specimen — Four-point loading

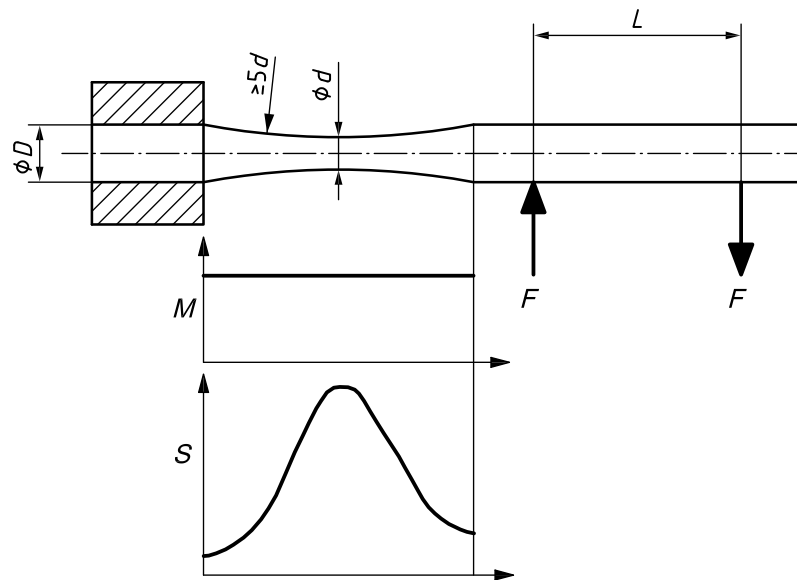

Key

- | | | | |
|-----|---|-----|------------------|
| D | diameter of gripped or loaded end of specimen | L | force arm length |
| d | diameter of specimen where stress is maximum | M | bending moment |
| F | applied force | S | stress |

Figure 6 — Hourglass specimen — Two-point loading

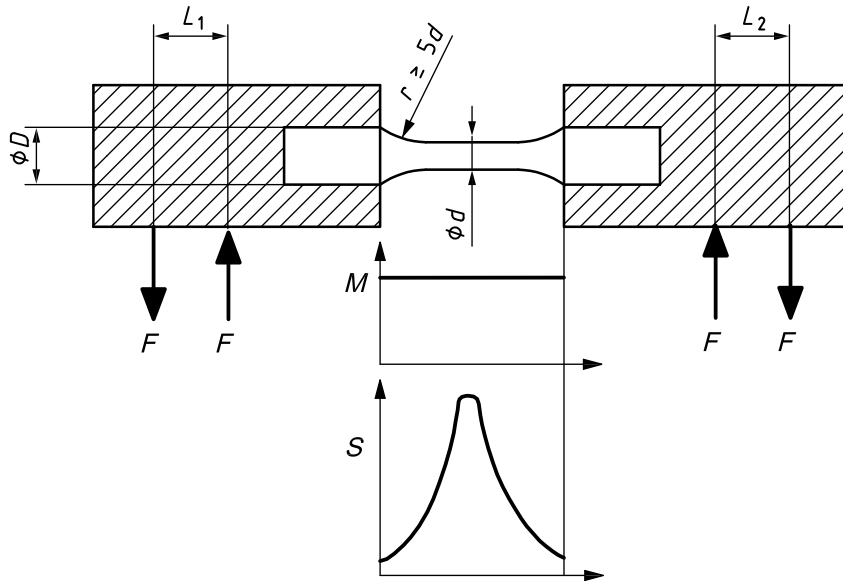

Key

- D diameter of gripped or loaded end of specimen
- d diameter of specimen where stress is maximum
- F applied force
- L_1, L_2 force arm lengths
- M bending moment
- r radius (see Table 1)
- S stress

Figure 7 — Hourglass specimen — Four-point loading

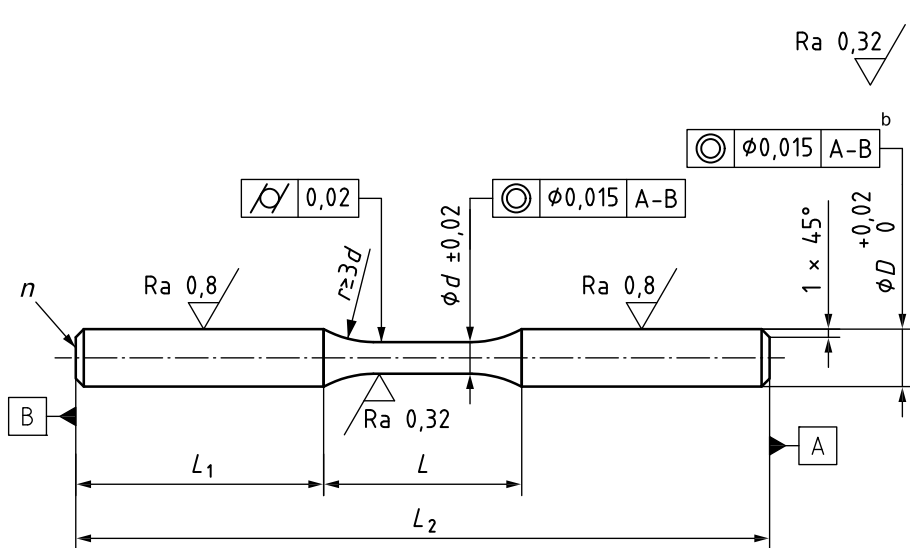

Key

- n specimen number
- a Others.
- b Two tops.

Figure 8 — Cylindrical smooth specimen

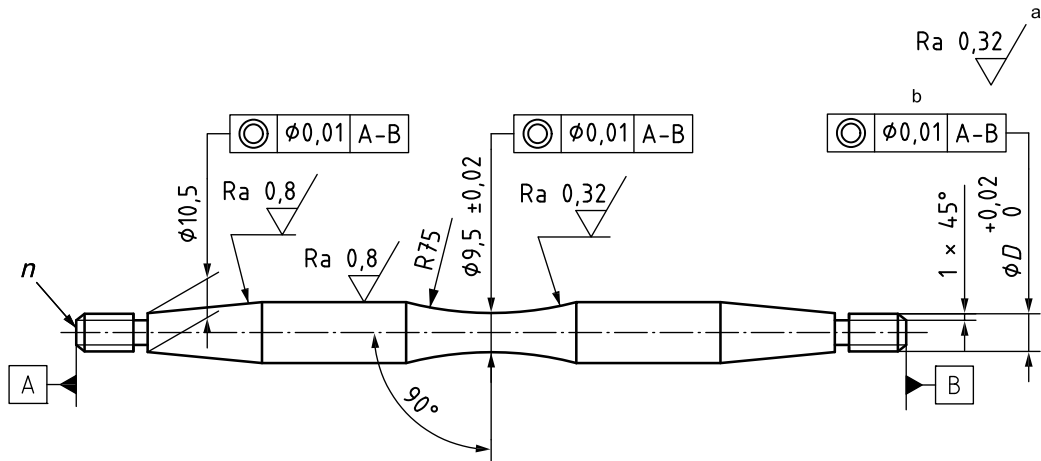

Key

- n* specimen number
- a Others.
- b Two tops.

Figure 9 — Cylindrical hourglass specimen

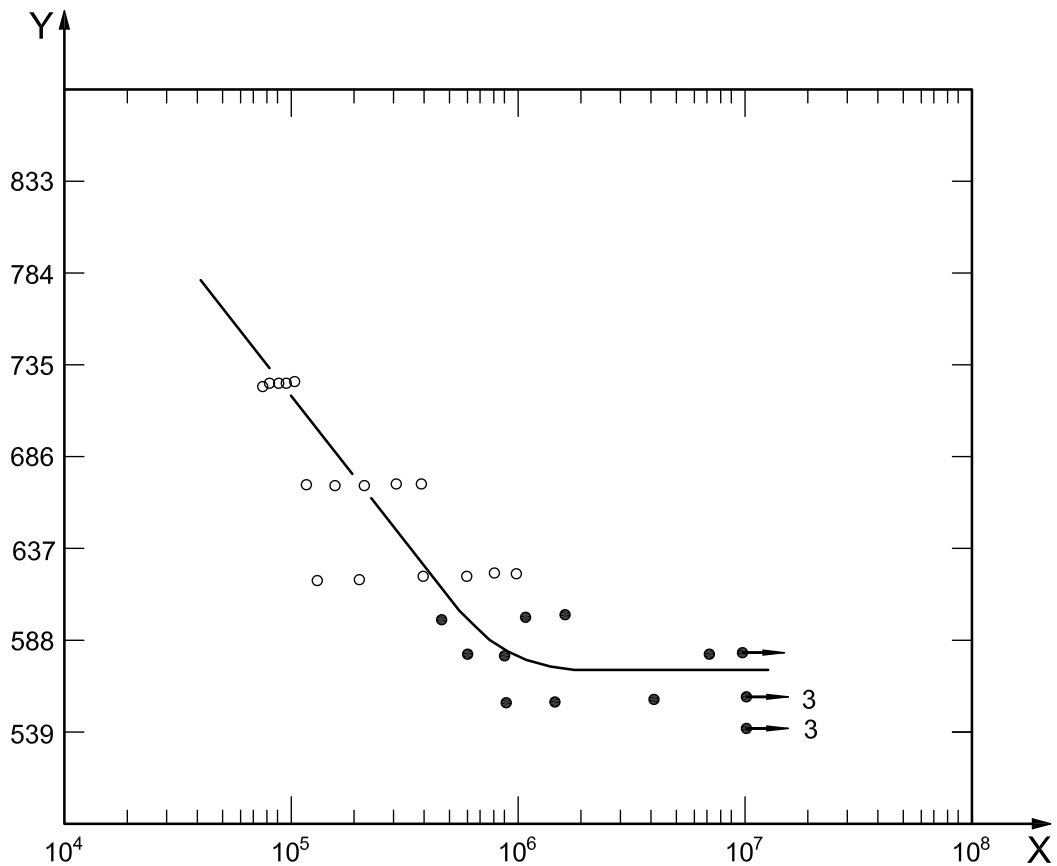

Key

- X fatigue life, N_f
- Y maximum stress, S_{max} , MPa

Black dots alone (●) represent failure and black dots with arrows (●→) represent a pass in the up and downs strategy test.

Figure 10 — S-N curve diagram

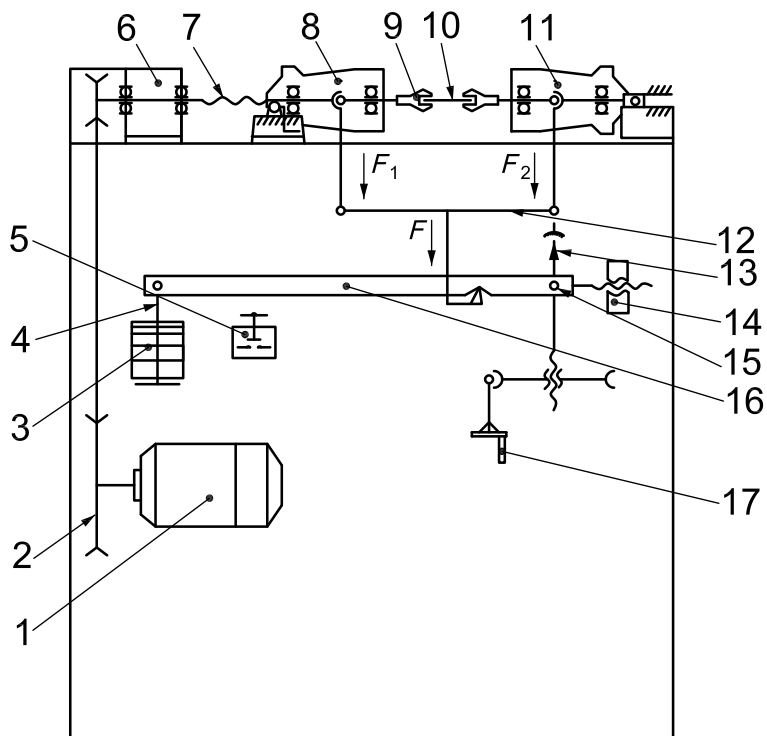

Key

- 1 motor
- 2 triangle belt
- 3 weight
- 4 boom
- 5 button
- 6 counting accelerator
- 7 soft axis
- 8 left main axis box
- 9 split collet
- 10 specimen
- 11 right main axis box
- 12 hanging hook
- 13 pointer
- 14 balance weight
- 15 counter
- 16 lever
- 17 hand wheel

Figure 11 — Schematic of a rotating bend fatigue machine

Annex A (normative)

Verification of the bending moment of rotating bar bending fatigue machines

A.1 Verification philosophies for rotating bar bending fatigue machines

Two approaches to verification of rotating bar bending fatigue machines are in common use. The first method uses dimensional measurement and subsequent calculations; the second a strain-gauged specimen.

This annex specifies verification equipment, pre-verification inspection, verification processes (either dimensional or strain gauge methods), assessment of the verification data and subsequent acceptance criteria.

A.2 Verification equipment

A.2.1 General

A range of equipment is used to verify the performance of rotating bar bending fatigue machines. Traceable forces are generated by either calibrated masses or calibrated force transducers. Where the test machine incorporates a lever and poise loading arrangement the forces are verified using a combination of both calibrated masses and force transducers. Dimensional measurements are made with calibrated measuring instruments, typically either micrometers and/or measurement callipers.

A.2.2 Masses

The masses used to apply the forces during the verification shall have an accuracy equal to or better than $\pm 0,1\%$, verified at least every five years and traceable to national standards.

A.2.3 Force transducers

Where a force transducer(s), i.e. load cell or cells are used to verify applied forces, these shall be calibrated in accordance with ISO 376 and shall be equal to or superior to Class 1.0.

A.2.4 Dimensional measurement

The micrometer(s) or measuring calliper(s) used to establish dimensional measurements from the rotating bend test machine shall have a resolution of at least 0,01 mm and an accuracy of at least 0,03 mm.

A.3 Inspection of the test machine prior to verification

Prior to verification, the component parts of the machine shall be inspected for wear and replaced if necessary. Any such replacement shall be recorded in the machine maintenance record.

A.4 Verification procedure — Verification by dimensional measurement

Rotating bar bending fatigue machines can be verified using a combination of dimensional measurements and force measurements. The various lever arms which convert the applied force to an applied moment on the specimen need to have their lengths measured very accurately (see A.4.2). The method of verification of the applied force will be dependent upon the load application system — whether it comes from a series of masses, a steelyard and poise system or a loading system utilizing a load cell. It may be necessary to utilize test machine specific fixtures, such as are shown in Figure A.1, to verify the applied force.

A.4.1 Temperature stabilization

Allow sufficient time for the verification equipment to equilibrate and attain a stable temperature. Record the temperature at the beginning and end of the verification process.

A.4.2 Measurement of mean force arm length

Measure, on each side of each arm, the force arm length (s), L — or L_1 and L_2 in the case of four-point bending machines — using a micrometer or vernier calliper (see Figures 1 to 7 and A.2). Repeat these measurements three times. Calculate the average value and record as the mean force arm length, \bar{L} ; the individual measurements should not vary by more than 5 %. Where the machine applies four-point bending, the measured mean values of L_1 and L_2 shall be within 1 % of each other.

The mean force arm length(s) are used in conjunction with the equations given in Table 2 for calculating the forces necessary to generate the required test stresses.

A.4.3 Measurement of loading arm lever ratio

Some designs of machine incorporate a lever arrangement to magnify the effective load or to invert a downward force into an upward one. Where such levers form part of the test machine, their effective lever ratio shall be determined. This calibration can be achieved by either precise dimensional measurement of the lever arm(s) and pivot distances, or by determination using a loadcell and calibrated masses. The resulting magnification ratio is recorded and is used in all test load calculations.

NOTE Guidance in the use of force transducers for making lever ratio measurements can be found in ISO 7500-2.

A.4.4 Calculation of required characteristics — Relative force accuracy error, q

A.4.4.1 Machines incorporating force transducer(s); i.e. load cell(s)

The relative force accuracy error, q , expressed as a percentage of the mean value, \bar{F} , of the true force is given by Equation (A.1):

$$q = \frac{F_i - \bar{F}}{\bar{F}} \times 100 \quad (\text{A.1})$$

where F_i is the force applied by the test machine to be verified.

A.4.4.2 Machines using test masses

The relative force accuracy error, q , for machines using test masses, is the percentage error reported in the calibration certificate for the test masses.

Where the machine incorporates loading levers, q is calculated by multiplying the percentage error of the test masses by the lever magnification ratio.

A.4.4.3 Machines using steelyard and poise loading

The relative force accuracy error, q , for steelyard and poise machines comprises two elements. The first of these, c , relates to the percentage accuracy of the measured mass of the poise weight, obtained from its calibration certificate. The second, d , relates to the discrimination of the scale on the steelyard (and any vernier on the poise weight).

The smallest discernable mass of the lever and poise system, m_e , is established by converting 2 mm of displacement on the scale into a corresponding load increment.

Where a load vernier is incorporated into the poise weight, then m_e is equal to the vernier load increment.

Smallest discernable mass m_e is converted to input d for the relative force accuracy error calculation by dividing it by the lowest working test load for the machine, expressed as a percentage.

The two elements c and d are combined using Equation (A.2):

$$q = \sqrt{(c^2 + d^2)} \quad (\text{A.2})$$

A.4.5 Calculation of required characteristics — Relative force repeatability error, b

A.4.5.1 Machines incorporating force transducer(s); i.e. load cell(s)

The relative force repeatability error, b , for each discrete force is the difference between the maximum and minimum values measured with respect to the mean value of true force. It is given by Equation (A.3):

$$b = \frac{F_{\max} - F_{\min}}{\bar{F}} \times 100 \quad (\text{A.3})$$

A.4.5.2 Machines using test masses

The relative force repeatability error, b , for machines utilizing test masses, is based upon the accuracy of the test masses. This is established by reviewing the calibration certificate for those test masses and establishing their metrological grading. This is then expressed as a percentage of the test mass.

A.4.5.3 Machines using steelyard and poise loading

The relative force repeatability error is established by experimentation, based upon the ability of the operators to set the poise weight to a defined position on the steelyard scale. To establish the repeatability error, the machine is set up to incorporate a force measurement system calibrated to ISO 376, Class 1.0, to be used to measure the applied force as indicated by the loadcell system. Each operator sets the machine, five times, to the specified load on the steelyard and a colleague records the resulting applied force. The relative force repeatability error, b , is the difference between the maximum, F_{\max} , and minimum, F_{\min} , values measured with respect to the mean value. It is given by Equation (A.3).

A.4.6 Calculation of required characteristics — Relative force arm accuracy error, q'

The relative accuracy error, q' , for the force arm is given by Equation (A.4):

$$q' = \frac{L_s - \bar{L}}{\bar{L}} \times 100 \quad (\text{A.4})$$

where

L_s is the force arm nominal value;

\bar{L} is the mean of the measured force arm length(s).

A.4.7 Calculation of required characteristics — Relative moment accuracy error, q''

The relative moment accuracy error, q'' , is given by Equation (A.5):

$$q'' = q + q' = \left[\frac{F_i - \bar{F}}{\bar{F}} + \frac{L_s - \bar{L}}{\bar{L}} \right] \times 100 \quad (\text{A.5})$$

A.4.8 Required performance characteristics

The maximum permissible error values are as follows:

- a) relative force accuracy (q) ± 1 % maximum;
- b) relative force repeatability (b) 1 % maximum;
- c) relative force arm accuracy (q') $\pm 0,3$ % maximum;
- d) relative moment accuracy (q'') $\pm 1,3$ % maximum.

A.5 Verification procedure — Verification using strain-gauged specimen**A.5.1 General**

A second approach to verifying rotating bar bending fatigue machines is to use a strain-gauged specimen similar in design to that used in testing. When preparing such a verification specimen, the critical diameter (highest stress location) shall be measured prior to the application of strain gauges. A typical verification test piece has two axial strain gauges 180° apart (gauges nos. 1 and 2). The technique may also be performed using a verification specimen with only one strain gauge (gauge no. 1). Convert strain gauge outputs to applied force using the elastic modulus of the strain-gauged, test-piece material, the measured critical diameter, d , and the appropriate equation found in Table 2. From this relationship of applied force and calculated specimen force, the applied force for all subsequent tests can be determined.

A.5.2 Temperature stabilization

Allow sufficient time for the verification equipment to equilibrate and attain a stable temperature. Record the temperature at the beginning and end of the application of each series of force measurements. Where necessary, apply temperature corrections to the deflections of the proving devices using the equations provided in the ISO 376 calibration certificate for the verification equipment.

A.5.3 Pre-verification conditioning

In order to ensure the machine is in good working condition, it is necessary to install a strain-gauged specimen and exercise the fatigue test machine and calibration equipment/fixtures three times between the initial force and the maximum force to be verified. After the third application, return the applied force to zero. If the calibration equipment/fixtures incorporate a force-proving device, then reset the output to zero.

A.5.4 Selection of test forces

Calculate a series of at least five, approximately equally spaced, forces between 20 % of the force range and the full force of the machine or between the minimum and maximum forces to be used.

A.5.5 Cantilever machines

A.5.5.1 Install the strain-gauged specimen in the machine at the motor end, the bending arm end remaining unconnected. Connect the strain gauges to the strain-gauge conditioning box and check for continuity of signal; subsequently, allow the specimen, machine components and electronics to stabilize thermally for 30 min. After this period, zero the electronics and strain gauge output.

A.5.5.2 Attach the bending arm to the specimen and link to the loading system. Then rotate the strain-gauged specimen until the output from the single gauge (or gauge no. 1 in a sample with two gauges) is a maximum; record the strain gauge output(s). Repeat this process at each applied force condition, rotating the strain-gauged specimen slightly to ensure the maximum bending is measured at each of the applied force conditions.

A.5.5.3 Force increments are achieved by application of known masses; where force is applied by a “steelyard & poise” system the force increments are achieved by movement of the poise weight along the steelyard.

A.5.5.4 When the initial force increments cycle is completed, remove the applied forces (but leave the bending arm in place); then repeat the sequence for force increment cycles nos. 2 and 3. Upon completion of force increment cycle 3, rotate the strain-gauged specimen approximately 180°. Initiate a second sequence of three force increment cycles, at each measurement maximizing the output from gauge no. 2 or, in the case of a single gauge specimen, maximizing the compressive strain output.

A.5.5.5 Upon completion of these measurements, remove the loading system and the bending arm; record a final measurement of the strain-gauge output(s). Then convert the recorded strain gauge measurements to applied specimen force using the appropriate equation in Table 2 for this type of test machine, the appropriate elastic modulus, E , for the strain-gauged specimen, and the measured gauge section diameter, d , for this specific strain-gauged specimen.

A.5.6 Four-point bending machines

A.5.6.1 Carry out an identical process to that set out in A.5.5 for the verification of four-point bending machines, with the exception of initial specimen set-up in the test machine. In this case, install one end of the strain-gauged specimen in the test machine at the motor end, with the other end remaining free at the non-motor end. Connect the strain gauges to the strain gauge conditioning box and check for continuity of signal; subsequently, allow the specimen, machine components and electronics to thermally stabilize for 30 min. After this period, zero the electronics, as per A.5.5.1.

A.5.6.2 Connect the non-motor end of the specimen to the test machine, and link everything to the loading system. Now begin the subsequent verification process, including maximizing and recording the strain gauge output at each loading increment as per A.5.5.2 to A.5.5.4. Once all of the data has been recorded for each of the three repeat loading conditions, convert the recorded strain gauge measurements to applied specimen force using the appropriate equation in Table 2 for this type of test machine, the appropriate elastic modulus, E , for the strain-gauged specimen, and the measured gauge section diameter, d , for this specific strain-gauged specimen, as per A.5.5.5.

A.5.7 Machines verified using a strain-gauged specimen

The data obtained from the verification process using strain gauges is used to establish the “tare” (minimum specimen force) when the machine has zero applied weight, and the relationship between applied force and specimen force. This relationship is subsequently used to establish the test forces required for specified test stresses, and also to determine the pertinent inputs to the machine classifications set out in A.5.8 and A.5.9.

A.5.8 Calculation of required characteristics — Relative force accuracy error, q

A.5.8.1 Machines incorporating force transducer(s); i.e. load cell(s)

The relative force accuracy error, q , expressed as a percentage of the mean value of the true force, \bar{F} , is given by Equation (A.1):

$$q = \frac{F_i - \bar{F}}{\bar{F}} \times 100 \quad (\text{A.1})$$

where F_i is the force applied by the test machine to be verified.

A.5.8.2 Machines using test masses

The relative force accuracy error, q , for machines using test masses, is the percentage error reported in the calibration certificate for the test masses, plus the tare error expressed as a percentage of the applied force.

Where the machine incorporates loading levers, q is calculated by multiplying the percentage error of the test masses by the lever magnification ratio plus the tare error expressed as a percentage of the applied force.

A.5.8.3 Machines using steelyard and poise loading

The relative force accuracy error, q , for steelyard and poise machines comprises two elements. The first of these, c , relates to the percentage accuracy of the measured mass of the poise weight, obtained from its calibration certificate. The second, d , relates to the discrimination of the scale on the steelyard (and any vernier on the poise weight). There is no tare error on this category of machine, as the steelyard and poise are balanced at zero force.

The smallest discernable mass of the lever and poise system, m_e , is established by converting 2 mm of displacement on the scale into a corresponding load increment.

Where a load vernier is incorporated into the poise weight, then m_e is equal to the vernier load increment.

Smallest discernable mass m_e is converted to input d for the relative force accuracy error calculation by dividing it by the lowest working test load for the machine, expressed as a percentage.

The two elements c and d are combined using Equation (A.2):

$$q = \sqrt{(c^2 + d^2)} \quad (\text{A.2})$$

A.5.9 Calculation of required characteristics — Relative force repeatability error, b

A.5.9.1 Machines incorporating force transducer(s); i.e. load cell(s)

The relative force repeatability error, b , for each discrete force is the difference between the maximum and minimum values measured with respect to the mean value of true force. It is given by Equation (A.3):

$$b = \frac{F_{\max} - F_{\min}}{\bar{F}} \times 100 \quad (\text{A.3})$$

A.5.9.2 Machines using test masses

The relative force repeatability error, b , for machines utilizing test masses, is based upon the accuracy of the test masses. This is established by reviewing the calibration certificate for the test masses and establishing their metrological grading. This is then expressed as a percentage of the test mass.

A.5.9.3 Machines using steelyard and poise loading

The relative force repeatability error is established by experimentation, based upon the ability of the operators to set the poise weight to a defined position on the steelyard scale. To establish the repeatability error, the machine is set up to incorporate a force measurement system calibrated to ISO 376, Class 1.0, to be used to measure the applied force as indicated by the loadcell system. Each operator sets the machine, five times, to the specified load on the steelyard and a colleague records the resulting applied force. The relative force repeatability error, b , is the difference between the maximum, F_{\max} , and minimum, F_{\min} , values measured with respect to the mean value. It is given by Equation (A.3).

A.5.10 Required performance characteristics

Machines are verified using a strain gauged test-piece, the maximum permissible error values are as follows:

- a) relative force accuracy (q) ± 1 % maximum;
- b) relative force repeatability (b) 1 % maximum.

A.6 Verification period

Test machines shall be verified annually or more frequently, as required. The time interval between verifications shall not exceed 13 months, except for test machines in which long-term tests are being performed that exceed this period. Under these circumstances, the test machine shall be verified upon completion of the test.

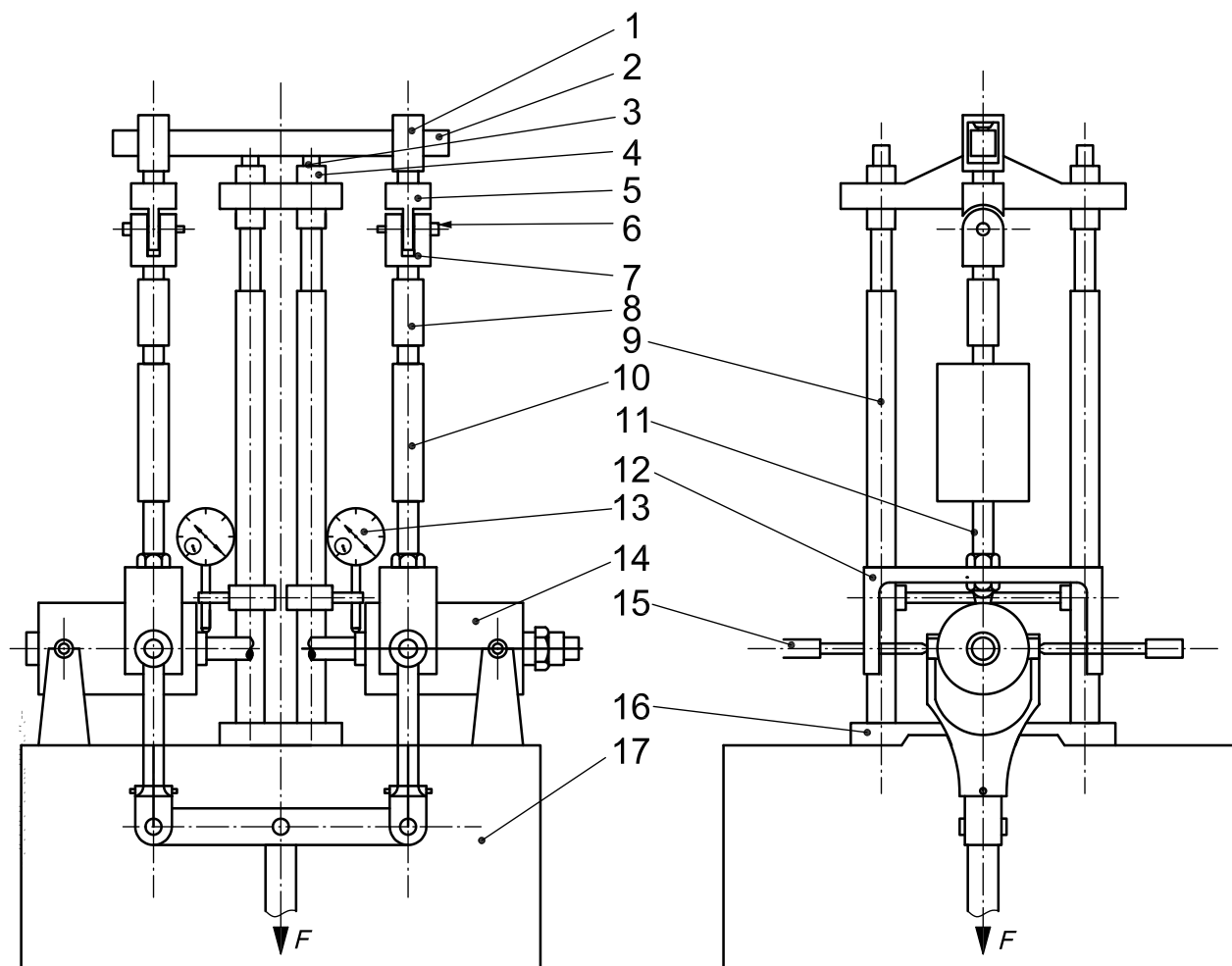

Key

- 1 framing
- 2 arm
- 3 former bearing rod
- 4 knurled nut
- 5 upper knuckle-joint
- 6 pin joint
- 7 lower knuckle-joint
- 8 upper connecting rod
- 9 latter bearing rod
- 10 force proving instrument
- 11 lower connecting rod
- 12 rack
- 13 micrometer
- 14 main axis box
- 15 knurled screw
- 16 frame foundation
- 17 box body

Figure A.1 — Example of calibration force measuring device on four-point bending machine

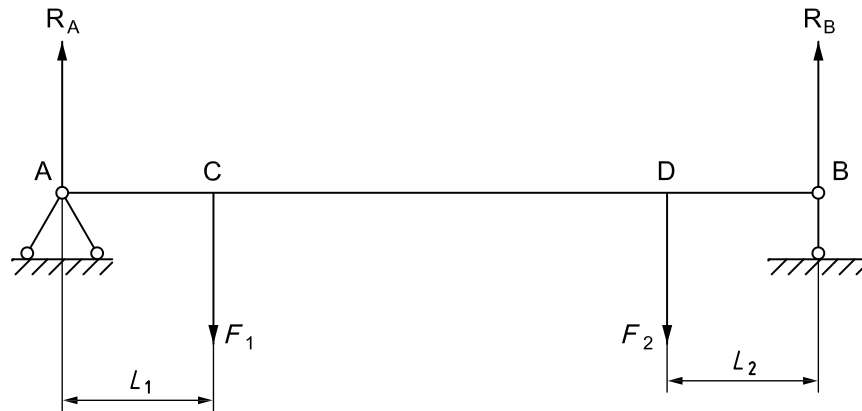
**Key**

- A left end pivot point
- B right end pivot point
- C left loading pivot
- D right loading pivot
- R_A supporting point
- R_B supporting point
- F_1, F_2 applied forces 1, 2
- L_1, L_2 force arm lengths

Figure A.2 — Schematic for moment arm determination — Four-point bending machine

Bibliography

- [1] ISO 7500-2, *Metallic materials — Verification of static uniaxial testing machines — Part 2: Tension creep testing machines — Verification of the applied force*
- [2] MANSON, S.S. and HALFORD, G.R. *Fatigue and Durability of Structural Materials*, 2006. ASM International, Materials Park, OH

ICS 77.040.10

Price based on 26 pages