

INTERNATIONAL STANDARD

**ISO
1124**

Third edition
1988-11-15



INTERNATIONAL ORGANIZATION FOR STANDARDIZATION
ORGANISATION INTERNATIONALE DE NORMALISATION
МЕЖДУНАРОДНАЯ ОРГАНИЗАЦИЯ ПО СТАНДАРТИЗАЦИИ

Rubber compounding ingredients — Carbon black shipment sampling procedures

*Ingrédients de mélange du caoutchouc — Procédures d'échantillonnage sur des livraisons de
noir de carbone*

Reference number
ISO 1124:1988 (E)

Foreword

ISO (the International Organization for Standardization) is a worldwide federation of national standards bodies (ISO member bodies). The work of preparing International Standards is normally carried out through ISO technical committees. Each member body interested in a subject for which a technical committee has been established has the right to be represented on that committee. International organizations, governmental and non-governmental, in liaison with ISO, also take part in the work. ISO collaborates closely with the International Electrotechnical Commission (IEC) on all matters of electrotechnical standardization.

Draft International Standards adopted by the technical committees are circulated to the member bodies for approval before their acceptance as International Standards by the ISO Council. They are approved in accordance with ISO procedures requiring at least 75 % approval by the member bodies voting.

International Standard ISO 1124 was prepared by Technical Committee ISO/TC 45, *Rubber and rubber products*.

This third edition cancels and replaces the second edition (ISO 1124 : 1983), of which it constitutes a technical revision.

Rubber compounding ingredients – Carbon black shipment sampling procedures

1 Scope

This International Standard specifies procedures for the sampling of carbon black for use in the rubber industry, delivered in bulk, semi-bulk or packages.

2 Definitions

For the purposes of this International Standard, the following definitions apply.

2.1 bulk: Carbon black delivered in containers holding not less than 2 000 kg.

2.2 semi-bulk: Carbon black delivered in containers holding more than 50 kg and less than 2 000 kg.

2.3 packages: Carbon black delivered in containers holding 50 kg or less.

3 Apparatus

3.1 Sample splitter, single-stage riffle type.

3.2 Sampling device for packages, comprising an open tube, of diameter not less than 25 mm, with a seal lip. The tube can be inserted into the package and the carbon black sample can be poured through it from the geometric centre of the package (see figure 1).

3.3 Airtight containers, 3 dm³ minimum capacity.

3.4 Scoop, designed to cause minimum pellet breakdown.

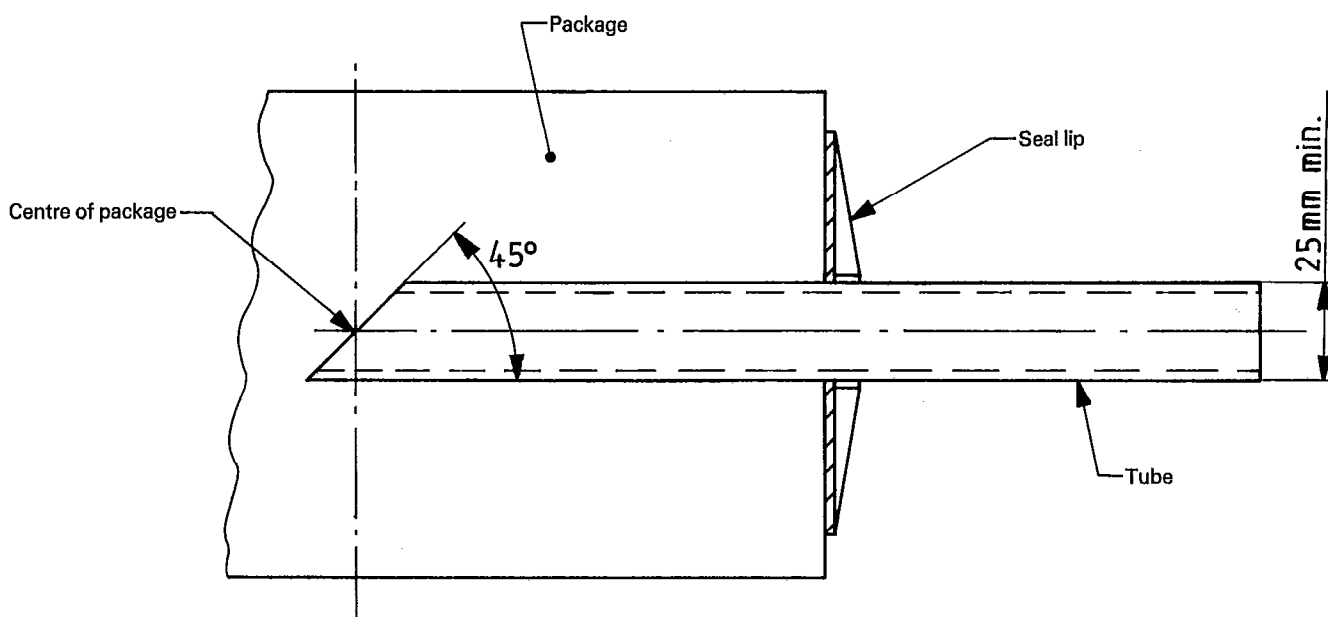

Figure 1 – Use of sampling device

4 Sampling procedures for bulk and semi-bulk containers

4.1 General

The method is for use in obtaining representative samples of the carbon black in each container, compartment or entire vehicle. The samples may be used to determine the average quality or to ascertain the variability in quality.

4.2 Bulk

Normally, each compartment of the bulk container is fitted with two laterally opposite sampling ports.

After first withdrawing and discarding from each port at least 5 dm³ of carbon black, take at least 1 kg in mass or 3 dm³ in volume from each port and place in an airtight container (3.3).

Should a container not be fitted with sampling ports, take at least 1 kg in mass or 3 dm³ in volume from the loading ports approximately 30 mm below the surface to avoid the inclusion of any surface contamination.

The portions comprising the sample shall be stored individually or composited, depending upon requirements.

4.3 Semi-bulk

The procedure described in 4.2 applies, but all samples shall be taken from the loading ports.

5 Sampling procedure for packages

Place the package of carbon black to be sampled in an upright position. Adjust the seal lip of the sampling device (3.2) to a distance from the bevelled end corresponding to the depth required to reach the geometric centre of the package. Make a slit at the approximate centre of the upper end of the package. Insert the sampling tube into the cut package, with the bevelled end pointing downwards, to the required depth. Hold the seal lip against the package to act as a seal. Hold the package at an angle and allow the carbon black to flow through the sample tube. Discard approximately the first 0,5 dm³ of sample material. Remove a sufficiently large sample for testing, i.e. at least 1 kg in mass or 3 dm³ in volume. Finally, place the package in the upright position again, remove the sampling device and seal the package opening. Take care not to break up the pellets with the sampling device.

Alternatively, use the scoop (3.4) to remove at least 1 kg in mass or 3 dm³ in volume from the geometric centre of the package after carefully removing at least 30 mm thickness of surface material to reach the centre of the package from the position sampled.

6 Treatment and storage of samples

6.1 If individual samples are taken for testing independently, pass each sample through the single-stage riffle-type sample splitter at least twice, in order to prevent stratification. This is particularly important if pellet quality tests are to be carried out on the samples. It is highly recommended that the mean quality of the shipment be calculated from the individual samples. This will provide maximum and minimum values (e.g. for loss on heating) as well as mean values.

If individual samples are composited for tests to produce average quality data only, pass them together through the single-stage riffle-type sample splitter at least three times.

6.2 Handle the portions taken for the determination of the pellet quality with care to avoid breakdown of the pellets.

6.3 Store the samples in airtight containers (3.3) until the tests are completed.

7 Sampling report

The sampling report shall include the following information:

- a) a reference to this International Standard;
- b) the numbers of portions taken for each sample;
- c) the appearance of the sample or samples, with particular reference to wetness or contamination, either of the sample or of the surface above the depth at which the sample was taken;
- d) if the sample is a composite one, the number of portions in the composite sample;
- e) identification of the samples;
- f) the location of each sample in the shipment;
- g) the mass or volume of the individual and composite samples;
- h) the number of packages, number of units, number of tiers or mass it represents;
- i) any deviation from the procedures specified in this International Standard.

ISO 1124 : 1988 (E)

UDC 678.046.2 : 620.11

Descriptors : rubber, ingredients, carbon black, sampling.

Price based on 2 pages
