

INTERNATIONAL STANDARD

ISO 1102

Third edition
2001-10-15

Commercial road vehicles — 50 mm drawbar eye — Interchangeability

*Véhicules routiers utilitaires — Anneaux de remorquage de 50 mm —
Interchangeabilité*



Reference number
ISO 1102:2001(E)

© ISO 2001

PDF disclaimer

This PDF file may contain embedded typefaces. In accordance with Adobe's licensing policy, this file may be printed or viewed but shall not be edited unless the typefaces which are embedded are licensed to and installed on the computer performing the editing. In downloading this file, parties accept therein the responsibility of not infringing Adobe's licensing policy. The ISO Central Secretariat accepts no liability in this area.

Adobe is a trademark of Adobe Systems Incorporated.

Details of the software products used to create this PDF file can be found in the General Info relative to the file; the PDF-creation parameters were optimized for printing. Every care has been taken to ensure that the file is suitable for use by ISO member bodies. In the unlikely event that a problem relating to it is found, please inform the Central Secretariat at the address given below.

© ISO 2001

All rights reserved. Unless otherwise specified, no part of this publication may be reproduced or utilized in any form or by any means, electronic or mechanical, including photocopying and microfilm, without permission in writing from either ISO at the address below or ISO's member body in the country of the requester.

ISO copyright office
Case postale 56 • CH-1211 Geneva 20
Tel. + 41 22 749 01 11
Fax + 41 22 749 09 47
E-mail copyright@iso.ch
Web www.iso.ch

Printed in Switzerland

Foreword

ISO (the International Organization for Standardization) is a worldwide federation of national standards bodies (ISO member bodies). The work of preparing International Standards is normally carried out through ISO technical committees. Each member body interested in a subject for which a technical committee has been established has the right to be represented on that committee. International organizations, governmental and non-governmental, in liaison with ISO, also take part in the work. ISO collaborates closely with the International Electrotechnical Commission (IEC) on all matters of electrotechnical standardization.

International Standards are drafted in accordance with the rules given in the ISO/IEC Directives, Part 3.

The main task of technical committees is to prepare International Standards. Draft International Standards adopted by the technical committees are circulated to the member bodies for voting. Publication as an International Standard requires approval by at least 75 % of the member bodies casting a vote.

Attention is drawn to the possibility that some of the elements of this International Standard may be the subject of patent rights. ISO shall not be held responsible for identifying any or all such patent rights.

ISO 1102 was prepared by Technical Committee ISO/TC 22, *Road vehicles*, Subcommittee SC 15, *Interchangeability of components of commercial vehicles and buses*.

This third edition cancels and replaces the second edition (ISO 1102:1986), which has been technically revised.

1

Commercial road vehicles — 50 mm drawbar eye — Interchangeability

1 Scope

This International Standard specifies the characteristics of 50 mm drawbar eyes, necessary for the interchangeability of the coupling components on trailers and permitting interchangeability between towing vehicles and trailers equipped with these components.

This International Standard is applicable to mechanical connections designed for commercial vehicles and trailers, the maximum total mass of which is above 3,5 t.

2 Normative references

The following normative documents contain provisions which, through reference in this text, constitute provisions of this International Standard. For dated references, subsequent amendments to, or revisions of, any of these publications do not apply. However, parties to agreements based on this International Standard are encouraged to investigate the possibility of applying the most recent editions of the normative documents indicated below. For undated references, the latest edition of the normative document referred to applies. Members of ISO and IEC maintain registers of currently valid International Standards.

ISO 8718, *Commercial road vehicles — Drawbar couplings and eyes for hinged drawbars — Strength tests*

ISO 12357, *Commercial road vehicles — Drawbar couplings and eyes for rigid drawbars — Strength tests*

3 Designation

Drawbar eyes meeting the requirements of this International Standard shall be identified by the following information, in the order given and when applicable:

- a) reference to this International Standard;
- b) code D 50 for drawbar eyes (non-classified);
- c) class of drawbar eye according to 4.4 for drawbar eyes meeting the additional requirements specified therein.

EXAMPLE 1 Non-classified 50 mm drawbar eye:

Drawbar eye ISO 1102 D 50

EXAMPLE 2 Classified 50 mm drawbar eye meeting the requirements of class C:

Drawbar eye ISO 1102 D 50-C

4 Drawbar eyes

4.1 General

The requirements of 4.2 and 4.3 are applicable to all 50 mm drawbar eyes. Additional requirements for classified drawbar eyes are given in 4.4.

4.2 General requirements

D 50 drawbar eyes shall be used as intended with C 50 drawbar couplings. The drawbar eye shall not be able to rotate axially.

NOTE 1 Mounting dimensions on the frame of towing vehicles, and dimensions and articulating angles of drawbar couplings are given in ISO 3584 [1].

NOTE 2 Dimensions for ensuring the operating clearance between towing vehicles and trailers are given in ISO 11406 [2] and ISO 11407 [3].

4.3 Dimensions

Dimensions of the D 50 drawbar eye shall be as shown in Figure 1. Dimensions not specified are left to the discretion of the component manufacturer.

Drawbar eyes fitted with sleeves shall comply with the dimensions shown in Figure 2 or Figure 3.

The characteristic dimensions of the D 50 drawbar eye (see Figure 1) are given in Table 1.

Table 1 — Characteristic dimensions of D 50 drawbar eye (non-classified)

Dimensions in millimetres

D 50	<i>h</i> max.	<i>b</i> max.
	80	62

4.4 Requirements for drawbar eyes of Class D 50-A to D 50-D

4.4.1 Dimensions

Dimensions of Classified D 50 drawbar eyes shall be according to

- Figure 1 and Table 2 for Class D 50-A drawbar eyes,
- Figure 4 for Class D 50-B drawbar eyes,
- Figure 5 for Class D 50-C drawbar eyes, or
- Figure 6 for Class D 50-D drawbar eyes.

Table 2 — Characteristic dimensions of D 50-A drawbar eyes

Dimensions in millimetres

D 50-A	h	b
	+2 -1	+2 -1
	65	60

4.4.2 Characteristic values

The drawbar eyes shall be suitable and tested for the minimum characteristic values given in Table 3.

Table 3 — Minimum characteristic values for classified drawbar eyes

Class	D kN	D_c kN	S kg	V kN
D 50-A	130	90	1 000	30
D 50-B	130	90	1 000	25
D 50-C	190	120	1 000	50
D 50-D	190	130	1 000	75

5 Test requirements

All 50 mm drawbar eyes shall be tested according to ISO 8718 or ISO 12357 or both.

Dimensions in millimetres

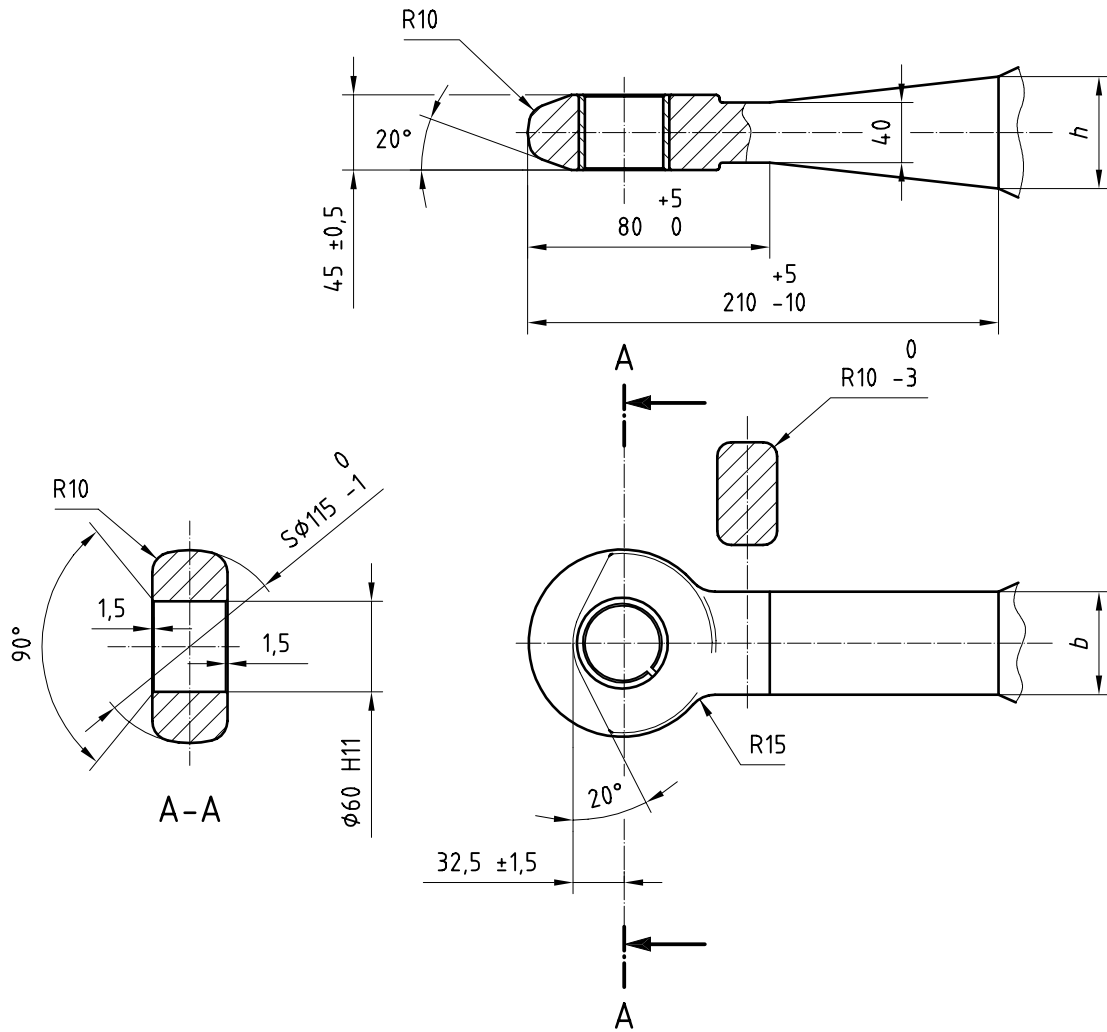

Figure 1 — Dimensions for D 50 and D 50-A drawbar eyes

Dimensions in millimetres

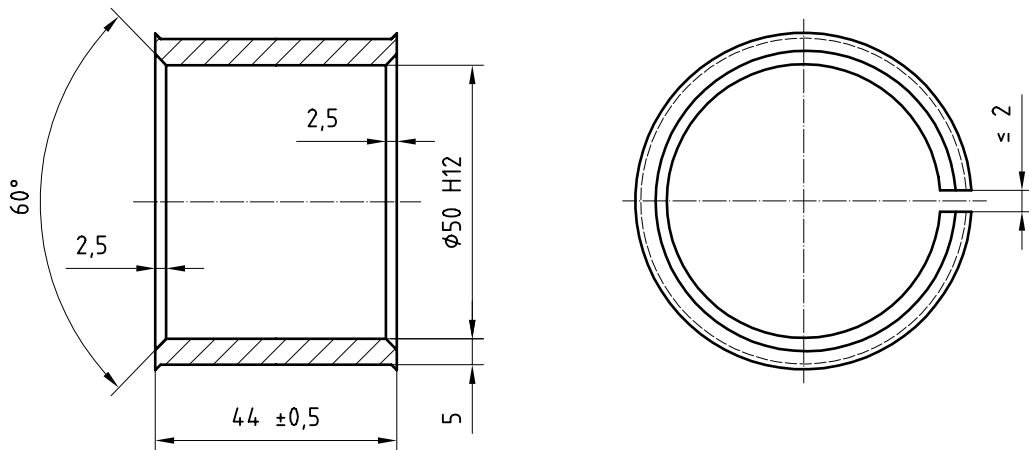

Figure 2 — Slotted sleeve for D 50 drawbar eyes in mounted conditions

Dimensions in millimetres

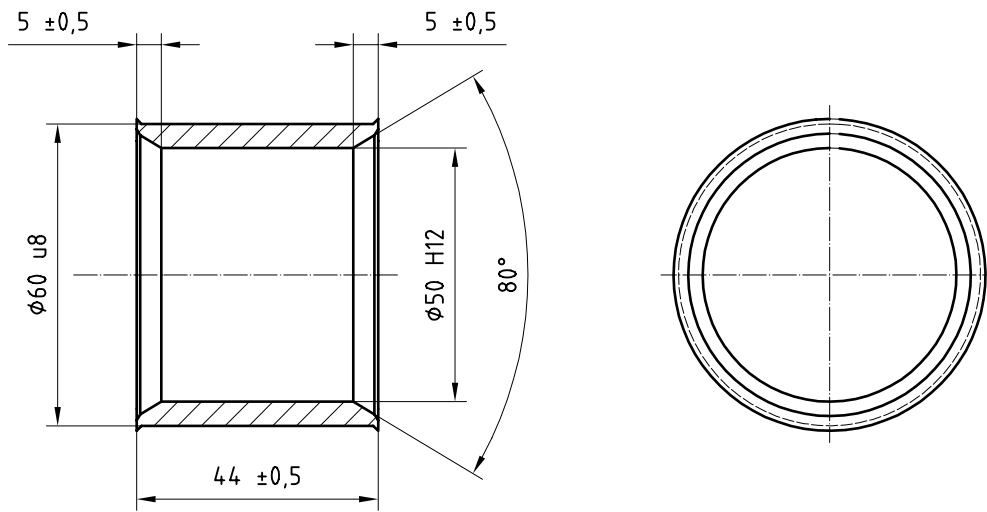
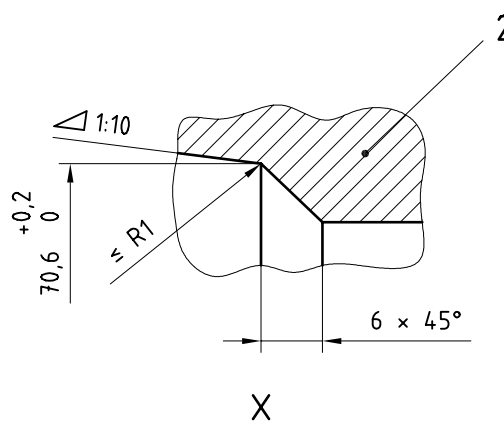
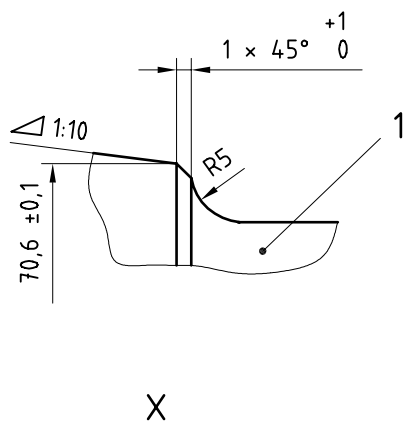
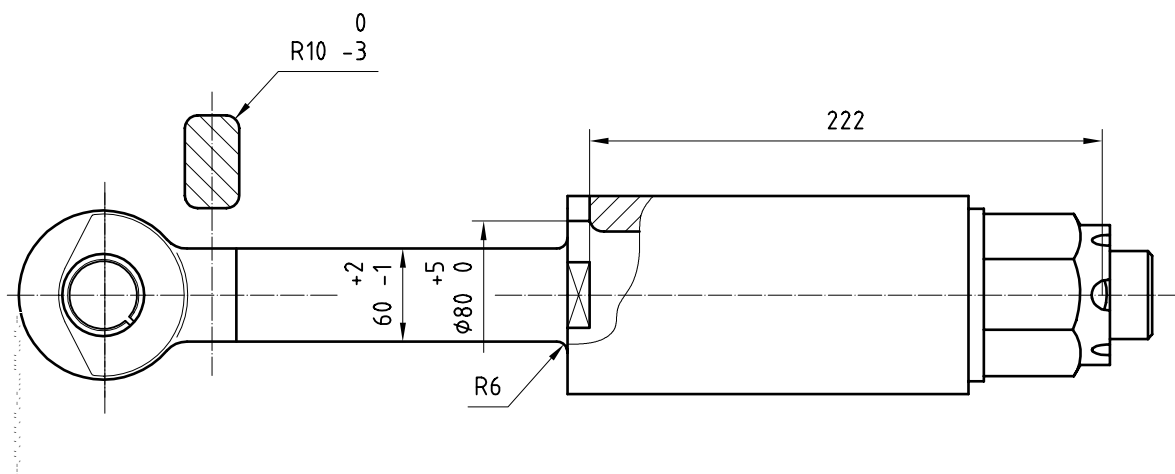
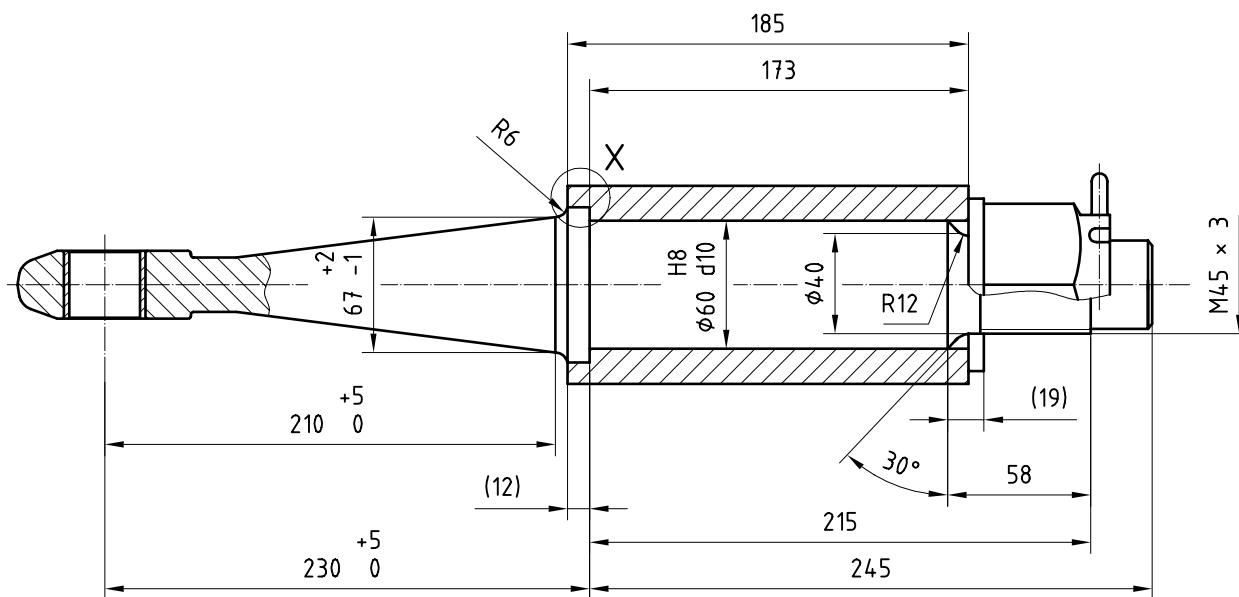

Figure 3 — Non-slotted sleeve for D 50 drawbar eyes in mounted conditions



Key

- 1 Drawbar eye
- 2 Drawbar eye socket

Figure 4 — Dimensions for D 50-B drawbar eyes

Dimensions in millimetres

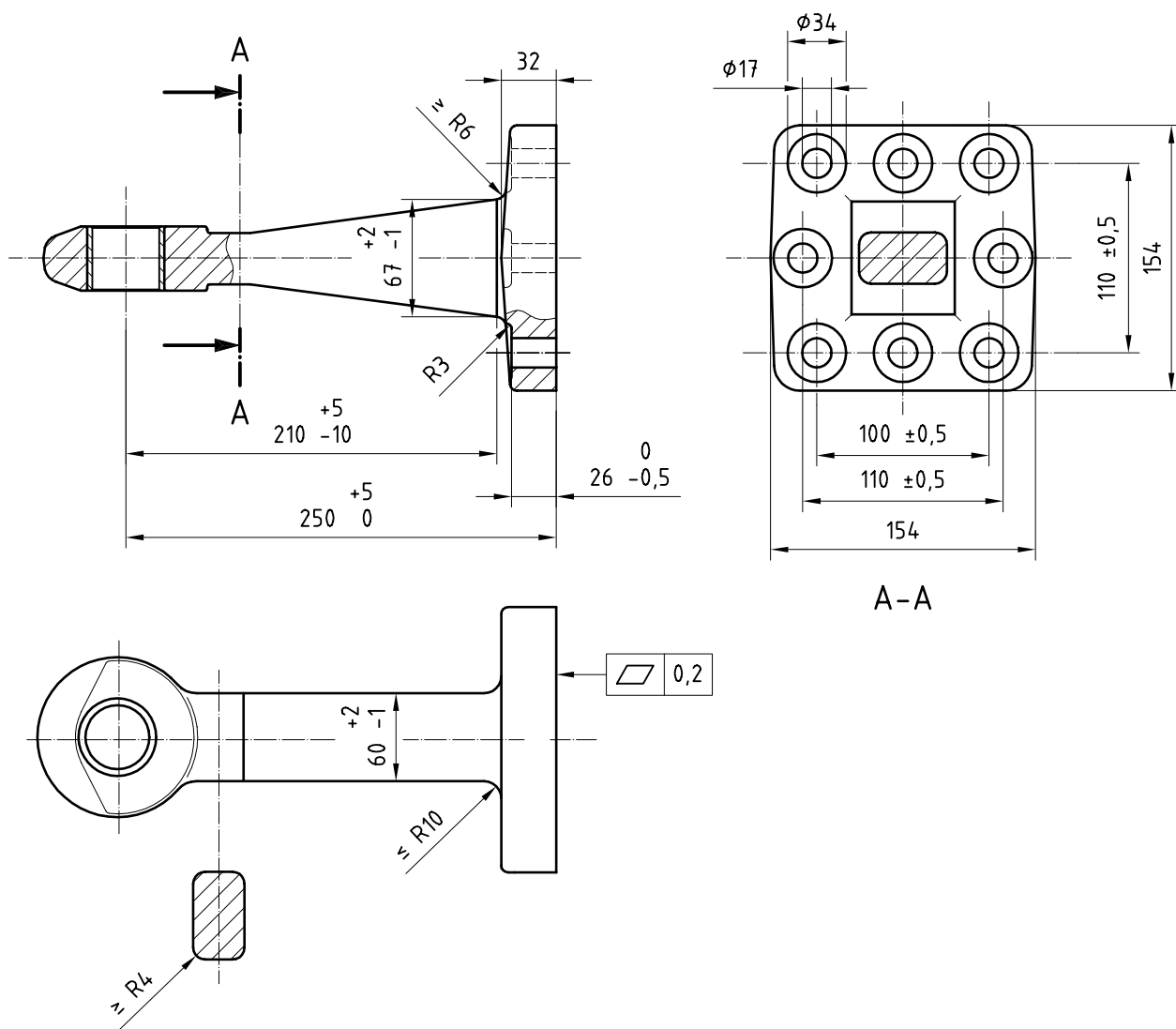

Figure 5 — Dimensions for D 50-C drawbar eyes

Dimensions in millimetres

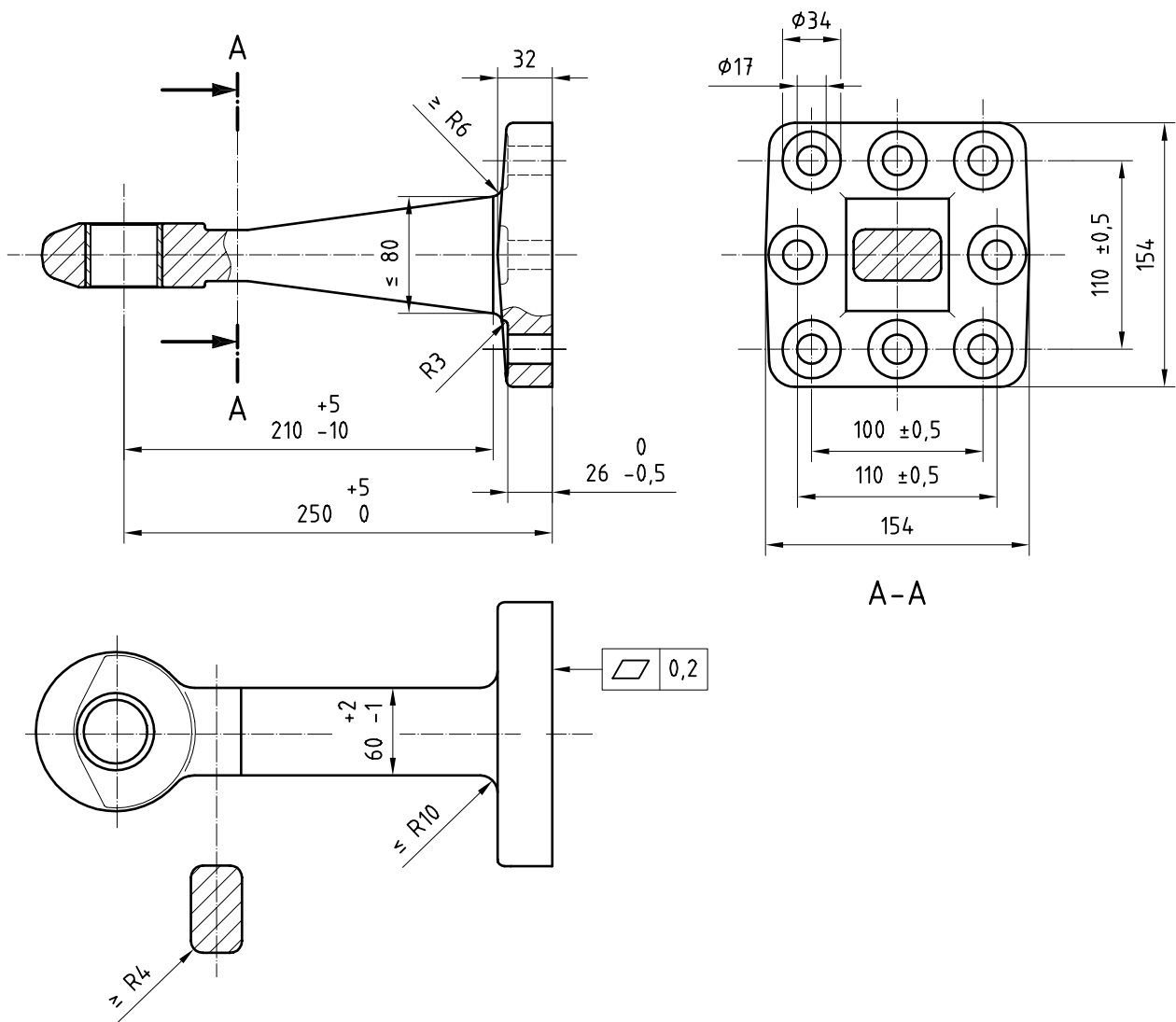

Figure 6 — Dimensions for D 50-D drawbar eyes

Bibliography

- [1] ISO 3584, *Road vehicles — Drawbar couplings — Interchangeability*
- [2] ISO 11406, *Commercial road vehicles — Mechanical coupling between towing vehicles with rear mounted coupling and drawbar trailers — Interchangeability*
- [3] ISO 11407, *Commercial road vehicles — Mechanical coupling between towing vehicles with coupling mounted forward and below, and centre-axle trailers — Interchangeability*

ICS 43.040.70

Price based on 9 pages

© ISO 2001 – All rights reserved