International Standard



1089

INTERNATIONAL ORGANIZATION FOR STANDARDIZATION • МЕЖДУНАРОДНАЯ ОРГАНИЗАЦИЯ ПО СТАНДАРТИЗАЦИИ • ORGANISATION INTERNATIONALE DE NORMALISATION

Electrode taper fits for spot welding equipment — Dimensions

Emmanchements coniques d'électrodes pour machines à souder par points — Dimensions

First edition — 1980-03-15

UDC 621.791.763.1.039

Ref. No. ISO 1089-1980 (E)

Descriptors : welding electrodes, resistance welding electrodes, spot welding, spigot and socket joints, taper, dimensions, dimensional tolerances.

Price based on 3 pages

Foreword

ISO (the International Organization for Standardization) is a worldwide federation of national standards institutes (ISO member bodies). The work of developing International Standards is carried out through ISO technical committees. Every member body interested in a subject for which a technical committee has been set up has the right to be represented on that committee. International organizations, governmental and non-governmental, in liaison with ISO, also take part in the work.

Draft International Standards adopted by the technical committees are circulated to the member bodies for approval before their acceptance as International Standards by the ISO Council.

International Standard ISO 1089 was developed by Technical Committee ISO/TC 44, *Welding and allied processes*, and was circulated to the member bodies in July 1978.

It has been approved by the member bodies of the following countries :

Belgium	Ireland	Poland
Brazil	Israel	Romania
Bulgaria	Italy	Spain
Canada	Japan	Switzerland
Egypt, Arab Rep. of	Korea, Rep. of	United Kingdom
France	Mexico	USSR
Germany, F. R.	New Zealand	
India	Norway	

The member bodies of the following countries expressed disapproval of the document on technical grounds :

Czechoslovakia
Sweden

This International Standard cancels and replaces ISO Recommendation R 1089-1969, of which it constitutes a technical revision.

Electrode taper fits for spot welding equipment — Dimensions

1 Scope and field of application

This International Standard lays down the taper dimensions and tolerances of electrode taper fits for spot welding electrode caps, electrode adaptors, electrode holders and similar parts, where the electrode force F_{\max} given for diameter d_1 in tables 1, 2 and 3 is not exceeded.

2 Dimensions

The dimensions shall be as given in the drawings and the tables.

3 Designation

Example of designation of an electrode taper fit type A and $d_1 = 16$ mm :

ISO 1089 — A 16

4 Marking

Electrode holders with electrode taper fit in accordance with this International Standard shall be marked with the designation (except the number of this International Standard); for example :

A 16

Type A
for spot welding electrodes
(straight thrust)

Type B
for spot welding electrodes
(eccentric loading)

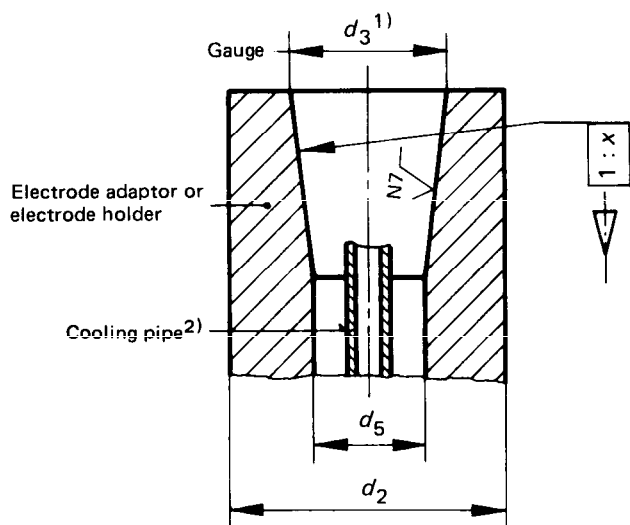
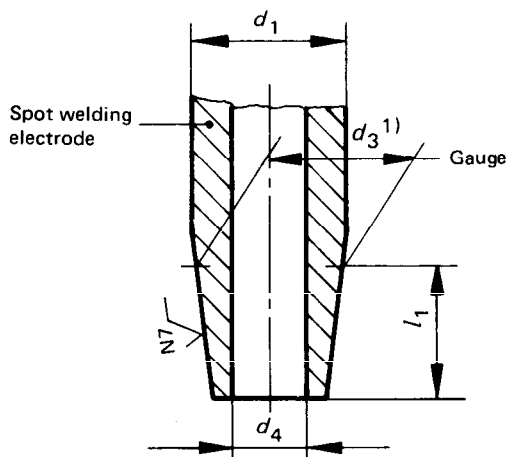

Type C
for electrode caps

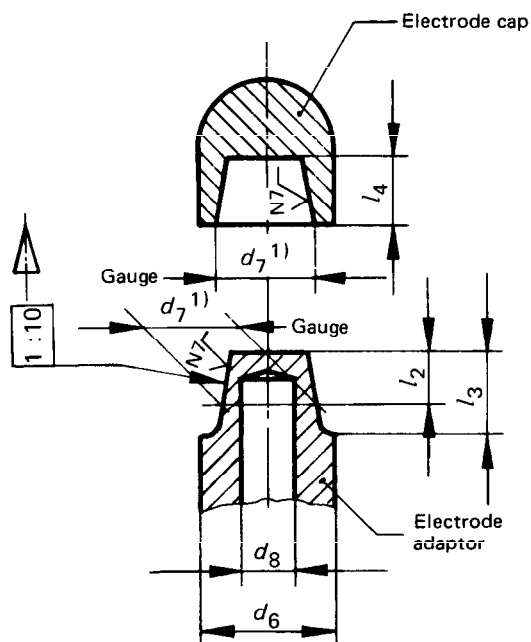

1) d_3 and d_7 are gauge dimensions at the datum line of the taper.

2) The size of the cooling pipe should be such that the cross-sectional area of its bore is approximately equal to the area of the annulus formed between its outside circumference and the cooling hole in the electrode.

Table 1 – Dimensions for type A

Dimensions in millimetres

Electrode fit	Taper 1 : x	d_1	d_2	d_3	d_4	d_5	$l_1 \pm 0,5$ straight thrust	Electrode force ¹⁾
								F_{\max} kN
A 10	1 : 10	10	16 20 25	9,8	5,5	8,5	13	2,5
A 13		13	20 25 31,5 40	12,7	7,5	11	16	4
A 16		16	25 31,5 40	15,5	8,5	13,5	20	6,3
A 20		20	31,5 40	19	10,5	16,5	25	10
A 25		25	40	24,5	13,5	21,5	31,5	16
A 32	1 : 5	32	50	31	14	23	40	25
A 40		40	63	39	16	29	50	40

Table 2 – Dimensions for type B

Dimensions in millimetres

Electrode fit	Taper 1 : x	d_1	d_2	d_3	d_4	d_5	$l_1 \pm 0,5$ eccentric loading	Electrode force ¹⁾
								F_{\max} kN
B 10	1 : 10	10	16 20 25	9,8	5,5	—	—	2,5
B 13		13	25 31,5 40	12,7	7,5	10	25	4
B 16		16	25 31,5 40	15,5	8,5	12,5	31,5	6,3
B 20		20	31,5 40	19	10,5	15	40	10
B 25		25	40	24,5	13,5	19,5	50	16
B 32	1 : 5	32	50	31	14	—	—	25
B 40		40	63	39	16	—	—	40

Table 3 – Dimensions for type C

Dimensions in millimetres

Electrode fit	d_6	d_7	d_8	$l_2 \pm 0,5$	l_3	$l_4 + 0,5$ 0	Electrode force ¹⁾
							F_{\max} kN
C 13	13	10	6,5	6,5	10	8	2,5
C 16	16	12	8	8	13	9,5	4
C 20	20	15	10,5	10	15	11,5	6,3

1) For information only.