

# INTERNATIONAL STANDARD

# ISO 1007

Third edition  
2000-06-01

---

---

## Photography — 135-size film and magazine — Specifications

*Photographie — Film et cartouche de format 135 — Spécifications*



Reference number  
ISO 1007:2000(E)

© ISO 2000

**PDF disclaimer**

This PDF file may contain embedded typefaces. In accordance with Adobe's licensing policy, this file may be printed or viewed but shall not be edited unless the typefaces which are embedded are licensed to and installed on the computer performing the editing. In downloading this file, parties accept therein the responsibility of not infringing Adobe's licensing policy. The ISO Central Secretariat accepts no liability in this area.

Adobe is a trademark of Adobe Systems Incorporated.

Details of the software products used to create this PDF file can be found in the General Info relative to the file; the PDF-creation parameters were optimized for printing. Every care has been taken to ensure that the file is suitable for use by ISO member bodies. In the unlikely event that a problem relating to it is found, please inform the Central Secretariat at the address given below.

© ISO 2000

All rights reserved. Unless otherwise specified, no part of this publication may be reproduced or utilized in any form or by any means, electronic or mechanical, including photocopying and microfilm, without permission in writing from either ISO at the address below or ISO's member body in the country of the requester.

ISO copyright office  
Case postale 56 • CH-1211 Geneva 20  
Tel. + 41 22 749 01 11  
Fax + 41 22 734 10 79  
E-mail [copyright@iso.ch](mailto:copyright@iso.ch)  
Web [www.iso.ch](http://www.iso.ch)

Printed in Switzerland

## Contents

	Page	
<b>1</b>	<b>Scope .....</b>	<b>1</b>
<b>2</b>	<b>Normative references .....</b>	<b>1</b>
<b>3</b>	<b>Terms and definitions .....</b>	<b>1</b>
<b>4</b>	<b>Conditions for measurement of dimensions .....</b>	<b>3</b>
<b>5</b>	<b>Film cutting and perforation dimensions .....</b>	<b>3</b>
<b>6</b>	<b>Latent-image frame numbering .....</b>	<b>9</b>
<b>7</b>	<b>Latent-image digital bar-codes.....</b>	<b>10</b>
<b>8</b>	<b>Magazine dimensions.....</b>	<b>20</b>
<b>9</b>	<b>Magazine bar-code .....</b>	<b>22</b>
<b>10</b>	<b>Camera auto-sensing areas.....</b>	<b>24</b>
<b>11</b>	<b>Magazine information panel .....</b>	<b>28</b>
<b>12</b>	<b>Process identification .....</b>	<b>29</b>
<b>13</b>	<b>Film pull-out force.....</b>	<b>29</b>
<b>14</b>	<b>Film-spool attachment strength .....</b>	<b>30</b>
	<b>Annex A (normative) Assignment of DX numbers.....</b>	<b>31</b>
	<b>Annex B (informative) Methods for measurement of key characteristics .....</b>	<b>34</b>
	<b>Annex C (informative) Historical dimensions used to design magazines and cameras .....</b>	<b>37</b>
	<b>Bibliography .....</b>	<b>38</b>
<b>Figures</b>		
	<b>Figure 1 — 135-size film and latent-image bar codes .....</b>	<b>5</b>
	<b>Figure 2 — Perforations for 135-size film (see Table 2).....</b>	<b>8</b>
	<b>Figure 3 — 135-size magazine bar-code (see Table 8).....</b>	<b>9</b>
	<b>Figure 4 — 135-size film magazine (see Table 7) .....</b>	<b>20</b>
	<b>Figure 5 — 135-size camera auto-sensing areas (see Table 10).....</b>	<b>25</b>
	<b>Figure 6 — 135-size magazine information panel (see Table 14) .....</b>	<b>29</b>
	<b>Figure B.1 — DC electrical circuit for camera auto-sensing testing .....</b>	<b>35</b>
	<b>Figure C.1 — Magazine design aims.....</b>	<b>37</b>
<b>Tables</b>		
	<b>Table 1 — Dimensions of 135-size film and latent-image identification (see Figure 1).....</b>	<b>6</b>
	<b>Table 2 — Dimensions for cutting and perforating 135-size film (see Figure 2).....</b>	<b>8</b>

Table 3 — Latent-image bar-code identification array: Part 1 DX numbers .....	12
Table 4 — Latent-image bar-code identification array: Part 2 DX numbers .....	13
Table 5 — Latent-image bar-code identification array: Dual-track frame-number codes .....	15
Table 6 — Latent-image bar-code identification array: Single-track frame-number codes .....	18
Table 7 — Dimensions of 135-size film magazine (see Figure 4).....	21
Table 8 — Dimensions of 135-size magazine bar-code (see Figure 3).....	23
Table 9 — Magazine bar-code: Assignment for number of exposures (digit 6).....	24
Table 10 — Dimensions of 135-size camera auto-sensing areas (see Figure 5).....	26
Table 11 — Auto-sensing areas: Code for ISO speed/exposure index .....	27
Table 12 — Auto-sensing areas: Code for number of exposures.....	28
Table 13 — Auto-sensing areas: Code for exposure latitude .....	28
Table 14 — Dimensions of 135-size magazine information panel (see Figure 6).....	29

.....

## Foreword

ISO (the International Organization for Standardization) is a worldwide federation of national standards bodies (ISO member bodies). The work of preparing International Standards is normally carried out through ISO technical committees. Each member body interested in a subject for which a technical committee has been established has the right to be represented on that committee. International organizations, governmental and non-governmental, in liaison with ISO, also take part in the work. ISO collaborates closely with the International Electrotechnical Commission (IEC) on all matters of electrotechnical standardization.

International Standards are drafted in accordance with the rules given in the ISO/IEC Directives, Part 3.

Draft International Standards adopted by the technical committees are circulated to the member bodies for voting. Publication as an International Standard requires approval by at least 75 % of the member bodies casting a vote.

Attention is drawn to the possibility that some of the elements of this International Standard may be the subject of patent rights. ISO shall not be held responsible for identifying any or all such patent rights.

International Standard ISO 1007 was prepared by Technical Committee ISO/TC 42, *Photography*.

This third edition cancels and replaces the second edition (ISO 1007:1995) which has been technically revised.

This revision of ISO 1007 includes the following significant additions and changes:

- a) A clause for definitions has been added in order to assist the reader of this International Standard in the proper interpretation of the information presented.
- b) A specification has been added for the single-track frame-number bar-codes, specifically the relationship of the eye-readable frame-number to its bar-code.
- c) In the dual-track frame-number bar-code system, encoding of frame numbers greater than 36A has been incorporated.
- d) The element width for the dual-track frame-number bar-code has been changed to allow element widths to be "narrower" than in the previous edition of this International Standard.
- e) The magazine bar-code system has been modified to allow for additional film lengths (digit 6), as well as a change to digit 1 for additional flexibility.
- f) Since part of 9.3 (DC electrical characteristics) was judged to apply to the test device (as opposed to the magazine itself), it has been moved to informative annex B. It is now consistent with the philosophy that test methods generally be documented only in informative annexes.
- g) The text regarding how manufacturers shall be assigned DX numbers has been improved significantly. A new method of using the magazine bar codes has been added to allow additional flexibility.
- h) Several issues that were included in the informative annexes of the second edition of this International Standard were judged to be obsolete. They have been removed in the interest of simplifying this revision, for example, measurements and calculations for estimating the location of film edges and measurement of velvet stiffness.

Annex A forms a normative part of this International Standard. Annexes B and C are for information only.



# Photography — 135-size film and magazine — Specifications

## 1 Scope

This International Standard specifies the following:

- dimensions of film lengths;
- latent-image frame numbering;
- latent-image digital bar-codes to identify the film DX number;
- dimensions of daylight-loading film magazines for use with 135-size cameras;
- a magazine bar-code that identifies the film's DX number as well as the number of exposures;
- camera auto-sensing areas, which provide an electrically readable encodement of film speed, number of exposures, and recommended exposure latitude for use with appropriately designed cameras;
- an information panel on which the film identification, speed and number of exposures are visible through a window in the back of appropriately designed cameras;
- film pull-out force specification;
- film-spool attachment strength specification.

This International Standard is not intended to apply to "bulk" 35-mm film used for reloading into 135-size magazines, nor to the reloadable magazines themselves. Also, this standard does not apply to 135-size film and magazines that are used in single-use camera applications.

## 2 Normative references

The following normative documents contain provisions which, through reference in this text, constitute provisions of this International Standard. For dated references, subsequent amendments to, or revisions of, any of these publications do not apply. However, parties to agreements based on this International Standard are encouraged to investigate the possibility of applying the most recent editions of the normative documents indicated below. For undated references, the latest edition of the normative document referred to applies. Members of ISO and IEC maintain registers of currently valid International Standards.

ISO 1:1975, *Standard reference temperature for industrial length measurements*.

ISO 554:1976, *Standard atmospheres for conditioning and/or testing — Specifications*.

## 3 Terms and definitions

For the purposes of this International Standard, the following terms and definitions apply.

NOTE Several terms (e.g. leader, trailer and tongue) have been defined in the text of this International Standard.

# ISO 1007:2000(E)

## 3.1

### **135-size**

name of the film format that uses 35 mm film, perforated on both edges, cut to standard lengths, and loaded into a specific size magazine for loading into 135-size cameras

## 3.2

### **aim dimension**

preferred dimension at which the manufacturing process will be aimed or designed

## 3.3

### **bar-code**

array of parallel rectangular bars and spaces that together represent data elements or characters in a particular symbology

NOTE 1 Bars and spaces are arranged in a predetermined pattern following unambiguous rules defined by the symbology.

NOTE 2 For more information on symbology and definitions related to bar-codes, refer to [1] in the bibliography.

## 3.4

### **basic dimension**

numerical value used to describe the theoretically exact size, profile, orientation, or location of a feature or a datum target

NOTE It is the basis from which permissible variations are established by tolerances on other dimensions, in notes, or in feature-control frames.

## 3.5

### **colour-negative process**

chemistry used to convert appropriately designed film into colour negatives for the purpose of creating colour prints

EXAMPLE C-41, CN-16, etc.

## 3.6

### **DX**

term that describes a system of encoding information on 135-size film and magazines that is useful in the operation of cameras and photofinishing equipment

NOTE This includes camera autosensing code, latent-image bar-codes, magazine bar-code and the magazine information panel.

## 3.7

### **DX number**

two-part number used to identify specific 135-size products

NOTE Part 1 is assigned by the Photographic & Imaging Manufacturers Association (PIMA) to the sensitizer. Part 2 is assigned by the sensitizer to each product.

## 3.8

### **exposure latitude**

range of exposures that yield satisfactory results

## 3.9

### **film**

flexible plastic material (usually transparent triacetate or polyester), coated with a sensitized gelatin layer (an emulsion) that can produce stable images upon exposure to light followed by chemical processing

## 3.10

### **film speed**

quantitative measure of the response of the photographic film to radiant energy for the specified conditions of exposure, processing, image density measurement, and analysis



**3.11****magazine**

light-tight chamber for film, made of metal and designed to fit into certain sizes of cameras

**3.12****perforations**

series of specified holes punched in the film near both edges for the purpose of film transport and locating

**3.13****spool**

cylindrical device that has a rim or edge at each end and an axial hole for a pin or spindle on which a roll of film is wound

**3.14****tolerances**

dimensions that define the boundaries of product conformance to this International Standard

NOTE When tolerances are expressed as "±", the reference is to the aim dimension.

## 4 Conditions for measurement of dimensions

The dimensions and tolerances specified in this International Standard shall apply at the time of manufacture (except where specifically stated otherwise), when measured under atmospheric conditions of  $(23 \pm 2)$  °C and  $(50 \pm 5)$  % relative humidity as specified in ISO 554.

All measuring instrument calibrations shall be conducted at a temperature of 20 °C, as specified in ISO 1, and a relative humidity of 50 %.

## 5 Film cutting and perforation dimensions

### 5.1 Film dimensions

The film shall conform to the dimensions shown in Figure 1 and given in Table 1, as well as those in Figure 2 and Table 2.

Dimension  $G$  in Figure 2 and Table 2 is the offset of any given side-to-side perforation pair.

**CAUTION — These dimensions apply at the time of cutting and may change over time.**

#### 5.1.1 Leader

The leader length dimension ( $Y_1 + Y_4$ ) is that part of the film that precedes full-frame number 1 and includes the tongue. It is used for threading the camera and protecting the picture area from unintentional exposure. The film manufacturer may utilize the portion of the leader extending from the magazine for identification purposes.

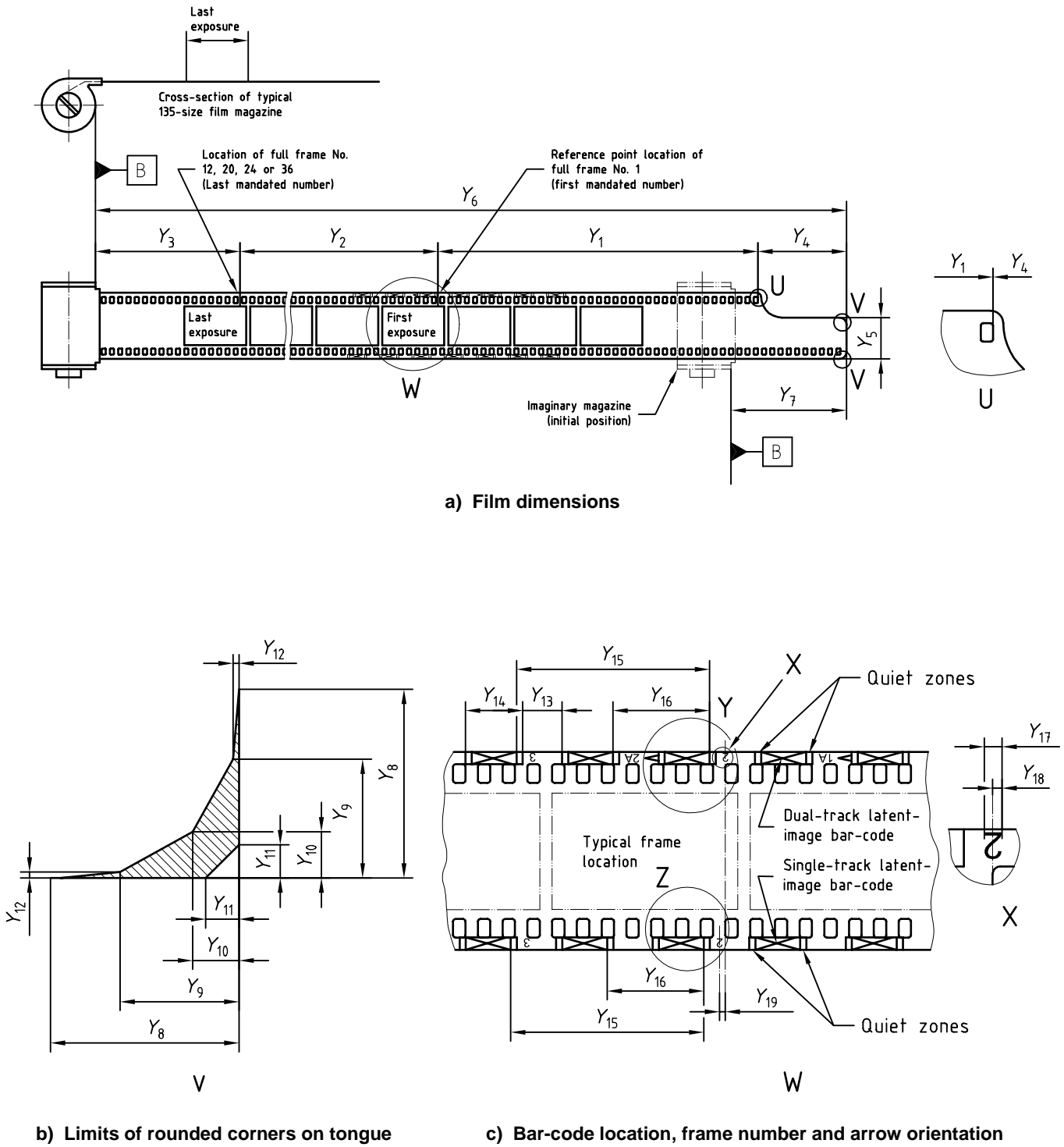
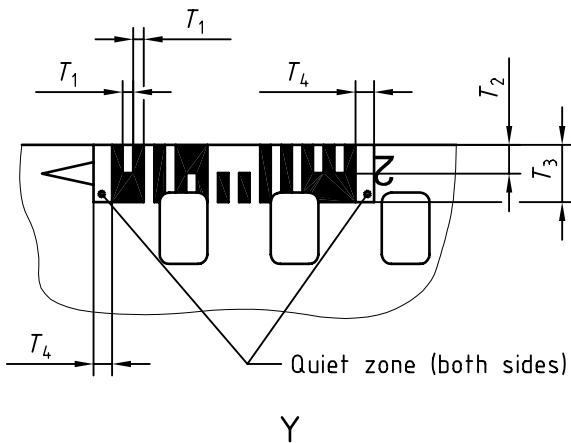
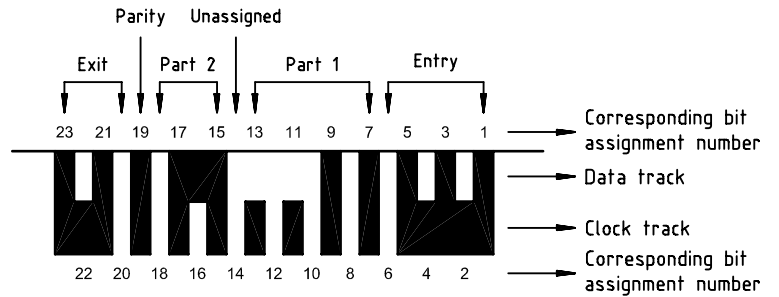

Figure 1 — 135-size film and latent-image bar codes



d) Dual-track bar-code dimensions



e) Latent-image dual-track bar-code

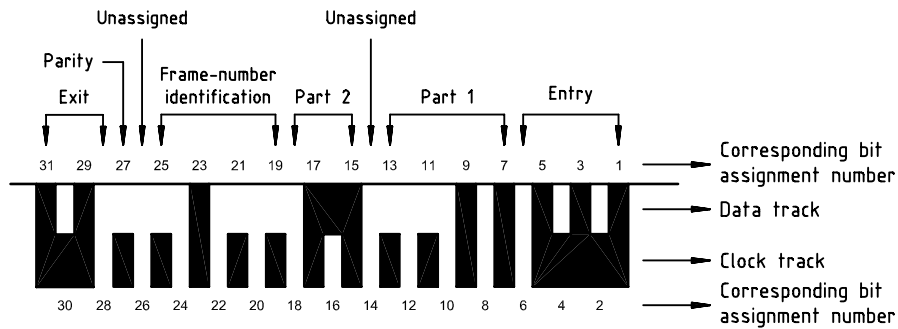

f) Latent-image dual-track bar-code with optional frame number <sup>a</sup>

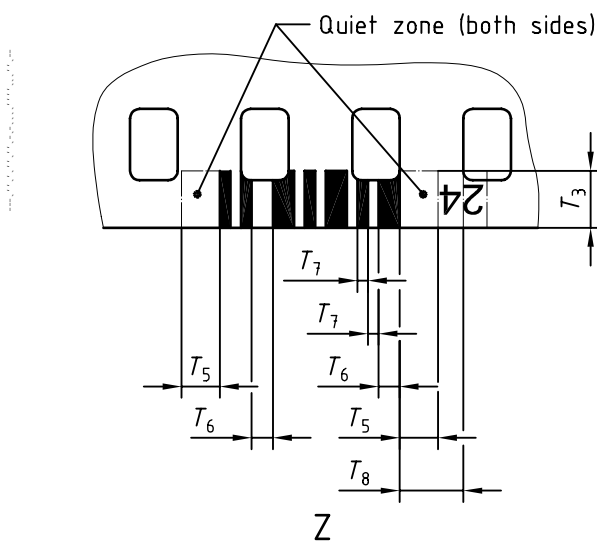

g) Optional single-track bar-code dimensions

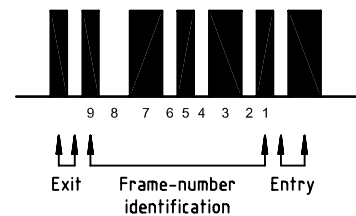

h) Optional latent-image single-track bar-code

NOTE Film shown with image-bearing side away from observer (see Table 1). For more information on the image-bearing side, refer to [2] in the bibliography.

<sup>a</sup> Bar-code dimensions are specified in d) by  $T_1$ ,  $T_2$ ,  $T_3$  and  $T_4$ .

Figure 1 (continued)

5.1.2 Tongue

The tongue is the narrow part of the leader, dimension  $Y_5$  in width and  $Y_4$  in length, shaped to facilitate camera loading and winding. The profile at the corners of the extreme leading end of the film tongue shall be rounded within the limits shown in Figure 1b) and given in Table 1. The corners shall have no stepped or sharp features. The cut across the end of the tongue shall not have steps that exceed 1,3 mm.

5.1.3 Trailer

The trailer, dimension  $Y_3$  in length, is that part of the film that extends from the last full-frame number to the B datum plane when the film has been pulled as far as possible out of the magazine. The trailer shall be composed entirely of full-width film to assure proper rewinding into the magazine.

Table 1 — Dimensions of 135-size film and latent-image identification (see Figure 1)

Dimensions in millimetres

Symbol	Minimum	Basic	Maximum	Remarks
$Y_1$	161,5	—	185,25	See note 1
$Y_2$	—	—	—	See note 2
$Y_3$	72,41	—	—	See note 3
$Y_4$	38,10	—	40,77	See note 4
$Y_5$	—	—	23	See note 5
$Y_6$	689,91	—	—	See note 6
	1145,91	—	—	12 exposures
	1601,91	—	—	24 exposures
		—	—	36 exposures
$Y_7$	43,91	—	71,76	See note 7
$Y_8$	—	—	5	
$Y_9$	—	3	—	
$Y_{10}$	—	—	1,3	
$Y_{11}$	0,8	—	—	
$Y_{12}$	—	—	0,2	
$Y_{13}$	6,35	—	—	See note 8
$Y_{14}$	—	11,61	—	See note 8
$Y_{15}$	—	38	—	See note 9
$Y_{16}$	—	19	—	See note 9
$Y_{17}$	—	—	—	See note 10
$Y_{18}$	—	—	—	See note 10
$Y_{19}$	—	—	0,5	See note 11
$T_1$	0,35	—	0,53	See note 12
$T_2$	0,75	—	1,26	
$T_3$	2,06	—	2,60	

Table 1 (continued)

Dimensions in millimetres

Symbol	Minimum	Basic	Maximum	Remarks
$T_4$	0,38	—	—	Quiet zone
$T_5$	1,5	—	—	Quiet zone
$T_6$	0,95	—	1,11	Wide element
$T_7$	0,38	—	0,54	Narrow element
$T_8$	2,60	3,10	3,60	See note 13

NOTE 1 Reference point for the dimensions is the full-frame number 1 (see clause 6).

NOTE 2 Distance from the first designated full-frame number to the last designated full-frame number.  $Y_2$  was given as a basic dimension in the 1995 edition of ISO 1007, but has been judged unnecessary for listing in this edition.

NOTE 3 Distance from the last designated full-frame number to the B datum plane.

NOTE 4 Distance from the end of the film to the leading edge of the first perforation in the full-width portion of the film.

NOTE 5 The measurement of tongue width is made at the extreme end. The shape of the rest of the tongue is optional.

NOTE 6 Minimum total film length from the end of the tongue to the B datum plane when the film is fully extended from the magazine.

NOTE 7 Distance from the end of the tongue to the B datum plane when the film is in its initial position.

NOTE 8 Dimensions  $Y_{13}$  and  $Y_{14}$  refer to dual-track latent-image bar-codes.  $Y_{14}$  includes quiet zones.  $Y_{13}$  is not specified under the optional frame-number bar-code system.

NOTE 9 Full-frame ( $Y_{15}$ ) and half-frame ( $Y_{16}$ ) pitch are basic dimensions.

NOTE 10  $Y_{17}$  and  $Y_{18}$  are used to define the centreline of the eye-readable frame number.

NOTE 11  $Y_{19}$  is always a positive number.

NOTE 12  $T_1$  is the width of any element (exposed or unexposed) in the clock track, data track, or both tracks. In order to enhance the effectiveness of some bar-code readers, the edge of any bar in the data track should be linear with an edge of a bar in the clock track.

NOTE 13 The distance from the centreline of the numerical frame-number to the nearest end of the corresponding frame-number bar-code. In cases where the numerical frame-number is 10 or more, the centreline is that for the numeral as a whole (see Figure 1).

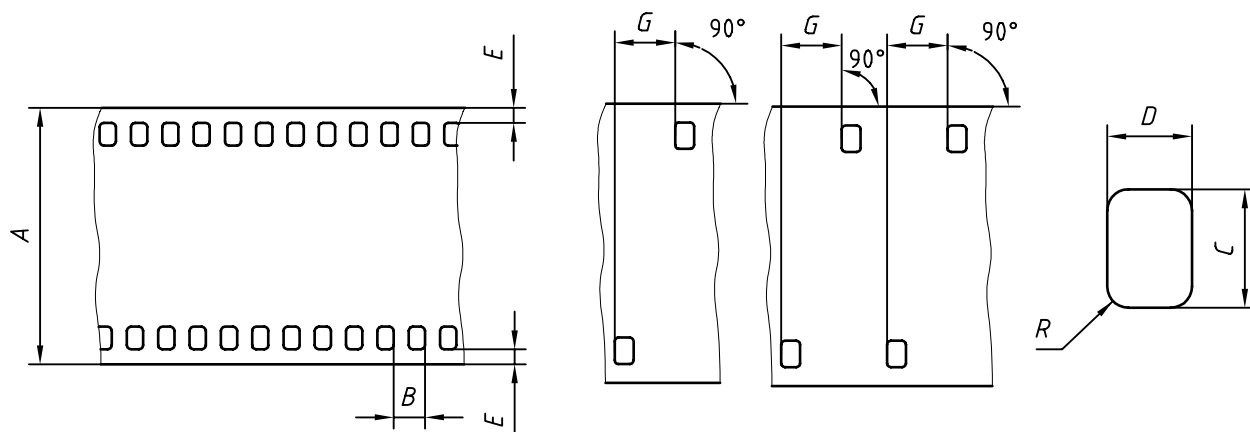

Figure 2 — Perforations for 135-size film (see Table 2)

Table 2 — Dimensions for cutting and perforating 135-size film (see Figure 2)

Dimensions in millimetres

Symbol	Aim and tolerances
<i>A</i>	$34,95 \pm 0,05$
<i>B</i>	$4,75 \pm 0,03$
<i>C</i>	$2,80 \pm 0,03$
<i>D</i>	$1,98 \pm 0,03$
<i>E</i>	$2,00 \pm 0,15$
<i>G</i> <sup>a</sup>	$0 \pm 0,1$
<i>R</i>	0,50 nominal
<i>L</i> <sup>b</sup>	$475 \pm 1,5$

<sup>a</sup> Represents the offset of any given side-to-side perforation pair.  
<sup>b</sup> Represents the length of any 100 consecutive perforation intervals.

## 6 Latent-image frame numbering

Two sets of frame-number sequences, together with their location and orientation, are shown in Figure 1c).

The first set shall be provided on the edge nearest to the C datum plane (see Figure 3). It shall be numbered in a half-frame series (1, 1A, 2, 2A, ..., 36, 36A) with the numbers interspersed at four-perforation intervals.

A second set may be provided on the edge opposite the first set. If provided, it may be numbered either in a full-frame series (1, 2, ..., 36) at intervals of eight perforations or, if provided as part of the optional single-track latent-image frame-number bar-code (see 7.3), it may be numbered in a half-frame series (1, 1A, 2, 2A, etc.).

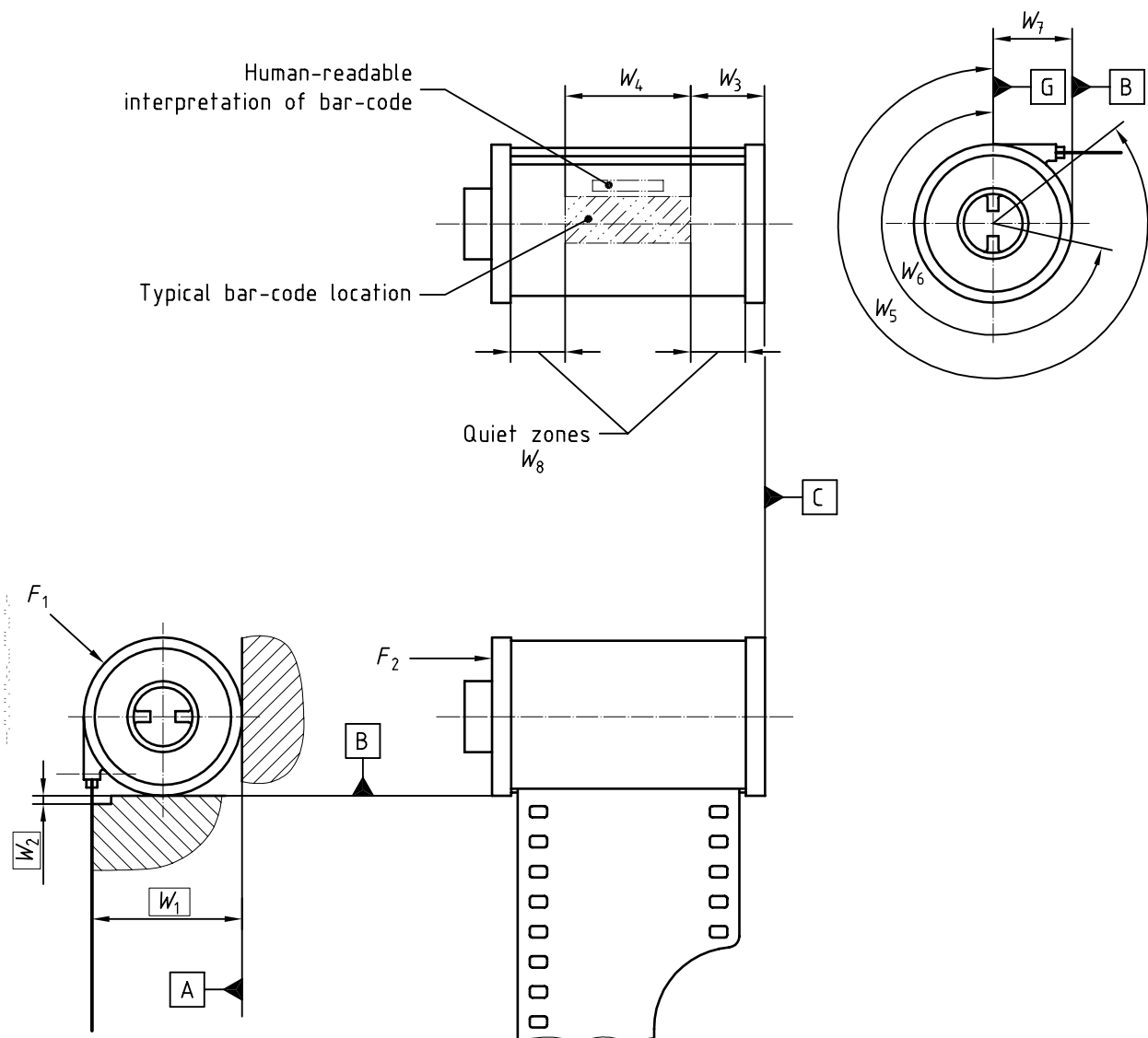

Figure 3 — 135-size magazine bar-code (see Table 8)

## 7 Latent-image digital bar-codes

### 7.1 General

Latent-image bar-codes shall conform to the locations and dimensions shown in Figure 1 and given in Table 1.

A 23-bit dual-track latent-image bar-code, which identifies the manufacturer/film type using a system of DX numbers (see normative annex A), shall be located on the edge nearest the C datum plane adjacent to each full-frame and half-frame number on films designed for colour-negative processing. The bar-codes are visible only after the film has been processed. When processed film is used with an appropriate film-code reader and an automatic printer, colour printing can be optimized for each specific film so identified.

Frame-number identification may also be incorporated in different ways. One method is to expand the basic 23-bit dual-track latent-image code by adding eight more bits for frame-number identification. Another method would be to utilize a 13-bit single-track, modified 3-of-9, latent-image bar-code on the opposite film edge.

Use of latent-image bar-codes on 135-size films, other than those intended for colour negative processing, is optional.

### 7.2 Dual-track latent-image bar-code

Each dual-track latent-image bar-code consists of adjacent data and clock tracks, each with the same number of elements (23 without and 31 with encoded frame numbers). Each bar-element represents a digital binary bit, with exposed elements (bars) representing a 1 bit and unexposed elements (spaces) representing a 0 (zero) bit, except in the entry pattern (see 7.2.1.1).

#### 7.2.1 Definition of the data track

The first reason for encoding information into the data track is to provide a unique DX number identification (see normative annex A for information regarding the assignment of DX numbers). The DX number has two parts (part 1 and part 2). The two parts are used in combination to identify products. Part 2 shall not be encoded without part 1. Part 1 is described in 7.2.1.2, and part 2 is described in 7.2.1.4.

The second reason for encoding information into the data track is to encode the frame numbers.

##### 7.2.1.1 Entry pattern

The 6-bit entry pattern is used by the bar-code reader to detect the beginning of a code sequence. The final bit of the entry pattern shall always be an unexposed element (space).

##### 7.2.1.2 Identification array for part 1 of the DX number

The part 1 DX code has 7 bits. The 7-bit stream, starting with bit 7 and ending with bit 13, is used for encoding the part 1 DX number assigned to a product in accordance with the procedure specified in annex A.

The sequences of exposed and unexposed positions that identify the 128 available part 1 DX numbers are given in Table 3. (They are arranged in an ascending binary sequence for ease of referencing.) Dashes (—) in one of the seven element position columns of Table 3 signify an unexposed element (space); a number signifies an exposed element (bar). For example, the part 1 DX number 41 is encoded by the combination of unexposed elements (spaces) in positions 7, 9, 11, and 12, and exposed elements (bars) in positions 8, 10, and 13.

Sensitizers may use a single part 1 DX number to identify a number of films that are designed for the same chemical process.

##### 7.2.1.3 Unassigned bit

The unassigned bit is in bit position 14 and shall be an unexposed element (space).



#### 7.2.1.4 Identification array for part 2 of the DX number

The identification for part 2 of the DX number is 4 bits, starting with bit 15 and ending with bit 18. This 4-bit array shall encode the specific part 2 DX number (specified in Table 4) that has been assigned to that product under the procedure specified in annex A. Any individual location assigned as part of the part 2 DX number shall represent an exposed element (bar). Dashes (—) in Table 4 represent an unexposed element (space).

The 16 possible combinations of this array are encoded as a 4-bit binary number, with bar position number 15 representing the most significant bit, and bar position number 18 representing the least significant bit.

#### 7.2.1.5 Identification array for frame numbers

This optional 7-bit array may be added to encode whole and half-frame numbers in accordance with the patterns given in Table 5. Bar positions 19 to 25 are a 7-bit binary representation of the frame number, with position number 19 representing the most significant bit and position number 25 representing the least significant bit. Frame numbers prior to the zero frame are derived by successive binary subtraction.

Bar position number 25 is exposed in those array's that encode half-frame numbers. This is the half-frame "flag".

Although the longest 135-size standard film length is 36 exposures, Table 5 provides the logical encodement for frame numbers greater than 36A in case these numbers should be needed in the future.

#### 7.2.1.6 Second unassigned bit

A second unassigned bit shall be included in bit position 26 only if the optional frame-number array is included. The second unassigned bit shall be an unexposed element (space).

#### 7.2.1.7 Parity bit

A parity bit shall be provided in bit position 19 in order to create even parity with data bits 7 through 18 inclusive. (The total number of exposed elements [bars] in data positions 7 through 18, plus the parity bit position, shall be an even number.)

Under the optional dual-track frame-numbering system, the parity bit is used to create even parity with data bits 7 through 25 inclusive and is located in bit position 27.

The unassigned bits are part of this consideration, but since they are always spaces they have no affect on the count of bars for parity.

#### 7.2.1.8 Exit pattern

The exit pattern shall be 4 bits as shown in Figure 1. It is used by a bar-code reader to detect the end of a code sequence.

Table 3 — Latent-image bar-code identification array: Part 1 DX numbers

Part 1 DX number	Bar position number						
	7	8	9	10	11	12	13
0	—	—	—	—	—	—	—
1	—	—	—	—	—	—	13
2	—	—	—	—	—	12	—
3	—	—	—	—	—	12	13
4	—	—	—	—	11	—	—
5	—	—	—	—	11	—	13
6	—	—	—	—	11	12	—
7	—	—	—	—	11	12	13
8	—	—	—	10	—	—	—
9	—	—	—	10	—	—	13
10	—	—	—	10	—	12	—
11	—	—	—	10	—	12	13
12	—	—	—	10	11	—	—
13	—	—	—	10	11	—	13
14	—	—	—	10	11	12	—
15	—	—	—	10	11	12	13
16	—	—	9	—	—	—	—
17	—	—	9	—	—	—	13
18	—	—	9	—	—	12	—
19	—	—	9	—	—	12	13
20	—	—	9	—	11	—	—
21	—	—	9	—	11	—	13
22	—	—	9	—	11	12	—
23	—	—	9	—	11	12	13
24	—	—	9	10	—	—	—
25	—	—	9	10	—	—	13
26	—	—	9	10	—	12	—
27	—	—	9	10	—	12	13
28	—	—	9	10	11	—	—
29	—	—	9	10	11	—	13
30	—	—	9	10	11	12	—
31	—	—	9	10	11	12	13
32	—	8	—	—	—	—	—
33	—	8	—	—	—	—	13
34	—	8	—	—	—	12	—
35	—	8	—	—	—	12	13
36	—	8	—	—	11	—	—
37	—	8	—	—	11	—	13
38	—	8	—	—	11	12	—
39	—	8	—	—	11	12	13
40	—	8	—	10	—	—	—

Part 1 DX number	Bar position number						
	7	8	9	10	11	12	13
41	—	8	—	10	—	—	13
42	—	8	—	10	—	12	—
43	—	8	—	10	—	12	13
44	—	8	—	10	11	—	—
45	—	8	—	10	11	—	13
46	—	8	—	10	11	12	—
47	—	8	—	10	11	12	13
48	—	8	9	—	—	—	—
49	—	8	9	—	—	—	13
50	—	8	9	—	—	12	—
51	—	8	9	—	—	12	13
52	—	8	9	—	11	—	—
53	—	8	9	—	11	—	13
54	—	8	9	—	11	12	—
55	—	8	9	—	11	12	13
56	—	8	9	10	—	—	—
57	—	8	9	10	—	—	13
58	—	8	9	10	—	12	—
59	—	8	9	10	—	12	13
60	—	8	9	10	11	—	—
61	—	8	9	10	11	—	13
62	—	8	9	10	11	12	—
63	—	8	9	10	11	12	13
64	7	—	—	—	—	—	—
65	7	—	—	—	—	—	13
66	7	—	—	—	—	12	—
67	7	—	—	—	—	12	13
68	7	—	—	—	11	—	—
69	7	—	—	—	11	—	13
70	7	—	—	—	11	12	—
71	7	—	—	—	11	12	13
72	7	—	—	10	—	—	—
73	7	—	—	10	—	—	13
74	7	—	—	10	—	12	—
75	7	—	—	10	—	12	13
76	7	—	—	10	11	—	—
77	7	—	—	10	11	—	13
78	7	—	—	10	11	12	—
79	7	—	—	10	11	12	13
80	7	—	9	—	—	—	—
81	7	—	9	—	—	—	13

Table 3 (continued)

Part 1 DX number	Bar position number						
	7	8	9	10	11	12	13
82	7	—	9	—	—	12	—
83	7	—	9	—	—	12	13
84	7	—	9	—	11	—	—
85	7	—	9	—	11	—	13
86	7	—	9	—	11	12	—
87	7	—	9	—	11	12	13
88	7	—	9	10	—	—	—
89	7	—	9	10	—	—	13
90	7	—	9	10	—	12	—
91	7	—	9	10	—	12	13
92	7	—	9	10	11	—	—
93	7	—	9	10	11	—	13
94	7	—	9	10	11	12	—
95	7	—	9	10	11	12	13
96	7	8	—	—	—	—	—
97	7	8	—	—	—	—	13
98	7	8	—	—	—	12	—
99	7	8	—	—	—	12	13
100	7	8	—	—	11	—	—
101	7	8	—	—	11	—	13
102	7	8	—	—	11	12	—
103	7	8	—	—	11	12	13
104	7	8	—	10	—	—	—

Part 1 DX number	Bar position number						
	7	8	9	10	11	12	13
105	7	8	—	10	—	—	13
106	7	8	—	10	—	12	—
107	7	8	—	10	—	12	13
108	7	8	—	10	11	—	—
109	7	8	—	10	11	—	13
110	7	8	—	10	11	12	—
111	7	8	—	10	11	12	13
112	7	8	9	—	—	—	—
113	7	8	9	—	—	—	13
114	7	8	9	—	—	12	—
115	7	8	9	—	—	12	13
116	7	8	9	—	11	—	—
117	7	8	9	—	11	—	13
118	7	8	9	—	11	12	—
119	7	8	9	—	11	12	13
120	7	8	9	10	—	—	—
121	7	8	9	10	—	—	13
122	7	8	9	10	—	12	—
123	7	8	9	10	—	12	13
124	7	8	9	10	11	—	—
125	7	8	9	10	11	—	13
126	7	8	9	10	11	12	—
127	7	8	9	10	11	12	13

Table 4 — Latent-image bar-code identification array: Part 2 DX numbers

Part 2 DX number	Bar position number			
	15	16	17	18
0	—	—	—	—
1	—	—	—	18
2	—	—	17	—
3	—	—	17	18
4	—	16	—	—
5	—	16	—	18
6	—	16	17	—
7	—	16	17	18
8	15	—	—	—
9	15	—	—	18
10	15	—	17	—
11	15	—	17	18
12	15	16	—	—
13	15	16	—	18
14	15	16	17	—
15	15	16	17	18

### 7.2.2 Clock track

The clock track shall be comprised of 23 bits if the data track does not contain optional frame-number encoding, or 31 bits if frame-number encoding is included in the data track. Each change in clock-track density signifies the location of a data bit in the data track [see Figure 1e) and 1f) for specific locations of bars and spaces].

### 7.2.3 Quiet zones

Quiet zones shall be provided on both ends of the bar-code, as shown in Figure 1d) and as given in Table 1.

## 7.3 Single-track latent-image frame-number bar-code

The optional single-track frame-number bar-code consists of seven bar elements interleaved with six space elements. Bar and space elements are either wide or narrow. Each element represents a digital binary bit, with wide elements representing a 1 bit and narrow elements representing a 0 bit.

### 7.3.1 Definition of data patterns

#### 7.3.1.1 Entry pattern

The entry pattern consists of one wide bar followed by one narrow space. It is used by a bar-code reader to detect the beginning of a code sequence.

#### 7.3.1.2 Frame-number sequence

The frame-number sequence consists of five bar elements interleaved with four space elements. There are three wide elements (3-of-9) and six narrow elements in each of the valid frame-number sequences. The pattern for each of the valid frame-number sequences shall be as given in Table 6, where a number in the bit column designates a 1 bit (wide element) and a dash (—) designates a zero bit (narrow element).

An optional end of roll sequence is provided for use at a location one full-frame pitch beyond the last full-frame number bar-code sequence (frame number E in Table 6).

Alternative frame-number sequences are provided for the last full-frame and half-frame numbers to indicate end of roll in 12, 20 and 24 exposure lengths. These alternative codes are marked with asterisks in Table 6.

#### 7.3.1.3 Exit pattern

The exit pattern consists of one narrow space followed by one narrow bar. It is used by a bar-code reader to detect the end of a code sequence.

### 7.3.2 Quiet zones

Quiet zones shall be provided on both ends of the bar-code, as shown in Figure 1g) and as given in Table 1.

## 7.4 Density specifications

The ISO standard status M red density of the unexposed elements (spaces) shall not exceed 0,50; the density difference between an unexposed element (space) and an exposed element (bar) shall be a minimum of 0,50. For additional information regarding status M red density, see ISO 5-3 ([2] in the bibliography).

The 690 nm density of the unexposed elements (spaces) shall not exceed 0,65; the density difference between an unexposed element (space) and an exposed element (bar) shall be a minimum of 0,90.

These requirements apply to the processed film, assuming that the product has been kept under recommended conditions before and after exposure, that the expiration date has not been exceeded, and that processing conforms with established standards.

Table 5 — Latent-image bar-code identification array: Dual-track frame-number codes

Frame number	7-bit pattern						
	19	20	21	22	23	24	25
XX	19	20	21	22	—	24	—
XXA	19	20	21	22	—	24	25
X	19	20	21	22	23	—	—
XA	19	20	21	22	23	—	25
00	19	20	21	22	23	24	—
00A	19	20	21	22	23	24	25
0	—	—	—	—	—	—	—
0A	—	—	—	—	—	—	25
1	—	—	—	—	—	24	—
1A	—	—	—	—	—	24	25
2	—	—	—	—	23	—	—
2A	—	—	—	—	23	—	25
3	—	—	—	—	23	24	—
3A	—	—	—	—	23	24	25
4	—	—	—	22	—	—	—
4A	—	—	—	22	—	—	25
5	—	—	—	22	—	24	—
5A	—	—	—	22	—	24	25
6	—	—	—	22	23	—	—
6A	—	—	—	22	23	—	25
7	—	—	—	22	23	24	—
7A	—	—	—	22	23	24	25
8	—	—	21	—	—	—	—
8A	—	—	21	—	—	—	25
9	—	—	21	—	—	24	—
9A	—	—	21	—	—	24	25
10	—	—	21	—	23	—	—
10A	—	—	21	—	23	—	25
11	—	—	21	—	23	24	—
11A	—	—	21	—	23	24	25
12	—	—	21	22	—	—	—
12A	—	—	21	22	—	—	25
13	—	—	21	22	—	24	—
13A	—	—	21	22	—	24	25
14	—	—	21	22	23	—	—
14A	—	—	21	22	23	—	25
15	—	—	21	22	23	24	—
15A	—	—	21	22	23	24	25
16	—	20	—	—	—	—	—
16A	—	20	—	—	—	—	25
17	—	20	—	—	—	24	—
17A	—	20	—	—	—	24	25
18	—	20	—	—	23	—	—
18A	—	20	—	—	23	—	25
19	—	20	—	—	23	24	—
19A	—	20	—	—	23	24	25

Table 5 (continued)

Frame number	7-bit pattern						
	19	20	21	22	23	24	25
20	—	20	—	22	—	—	—
20A	—	20	—	22	—	—	25
21	—	20	—	22	—	24	—
21A	—	20	—	22	—	24	25
22	—	20	—	22	23	—	—
22A	—	20	—	22	23	—	25
23	—	20	—	22	23	24	—
23A	—	20	—	22	23	24	25
24	—	20	21	—	—	—	—
24A	—	20	21	—	—	—	25
25	—	20	21	—	—	24	—
25A	—	20	21	—	—	24	25
26	—	20	21	—	23	—	—
26A	—	20	21	—	23	—	25
27	—	20	21	—	23	24	—
27A	—	20	21	—	23	24	25
28	—	20	21	22	—	—	—
28A	—	20	21	22	—	—	25
29	—	20	21	22	—	24	—
29A	—	20	21	22	—	24	25
30	—	20	21	22	23	—	—
30A	—	20	21	22	23	—	25
31	—	20	21	22	23	24	—
31A	—	20	21	22	23	24	25
32	19	—	—	—	—	—	—
32A	19	—	—	—	—	—	25
33	19	—	—	—	—	24	—
33A	19	—	—	—	—	24	25
34	19	—	—	—	23	—	—
34A	19	—	—	—	23	—	25
35	19	—	—	—	23	24	—
35A	19	—	—	—	23	24	25
36	19	—	—	22	—	—	—
36A	19	—	—	22	—	—	25
37	19	—	—	22	—	24	—
37A	19	—	—	22	—	24	25
38	19	—	—	22	23	—	—
38A	19	—	—	22	23	—	25
39	19	—	—	22	23	24	—
39A	19	—	—	22	23	24	25
40	19	—	21	—	—	—	—
40A	19	—	21	—	—	—	25
41	19	—	21	—	—	24	—
41A	19	—	21	—	—	24	25
42	19	—	21	—	23	—	—
42A	19	—	21	—	23	—	25

Table 5 (continued)

Frame number	7-bit pattern						
	19	20	21	22	23	24	25
43	19	—	21	—	23	24	—
43A	19	—	21	—	23	24	25
44	19	—	21	22	—	—	—
44A	19	—	21	22	—	—	25
45	19	—	21	22	—	24	—
45A	19	—	21	22	—	24	25
46	19	—	21	22	23	—	—
46A	19	—	21	22	23	—	25
47	19	—	21	22	23	24	—
47A	19	—	21	22	23	24	25
48	19	20	—	—	—	—	—
48A	19	20	—	—	—	—	25
49	19	20	—	—	—	24	—
49A	19	20	—	—	—	24	25
50	19	20	—	—	23	—	—
50A	19	20	—	—	23	—	25
51	19	20	—	—	23	24	—
51A	19	20	—	—	23	24	25
52	19	20	—	22	—	—	—
52A	19	20	—	22	—	—	25
53	19	20	—	22	—	24	—
53A	19	20	—	22	—	24	25
54	19	20	—	22	23	—	—
54A	19	20	—	22	23	—	25
55	19	20	—	22	23	24	—
55A	19	20	—	22	23	24	25
56	19	20	21	—	—	—	—
56A	19	20	21	—	—	—	25
57	19	20	21	—	—	24	—
57A	19	20	21	—	—	24	25
58	19	20	21	—	23	—	—
58A	19	20	21	—	23	—	25
59	19	20	21	—	23	24	—
59A	19	20	21	—	23	24	25
60	19	20	21	22	—	—	—
60A	19	20	21	22	—	—	25

Table 6 — Latent-image bar-code identification array: Single-track frame-number codes

Frame number	Code element									Remarks
	B 1	S 2	B 3	S 4	B 5	S 6	B 7	S 8	B 9	
00	—	—	—	4	—	6	—	8	—	See note 1
00A	—	2	—	—	—	6	—	8	—	See note 1
0	1	—	3	—	—	—	—	8	—	See note 1
0A	1	—	—	—	5	—	—	8	—	See note 1
1	—	—	3	—	5	—	—	8	—	
1A	1	—	—	—	—	—	7	8	—	
2	—	—	3	—	—	—	7	8	—	
2A	—	—	—	—	5	—	7	8	—	
3	1	—	3	—	—	6	—	—	—	
3A	1	—	—	—	5	6	—	—	—	
4	—	—	3	—	5	6	—	—	—	
4A	1	—	3	4	—	—	—	—	—	
5	1	2	3	—	—	—	—	—	—	
5A	1	—	—	4	5	—	—	—	—	
6	—	—	3	4	5	—	—	—	—	
6A	1	2	—	—	5	—	—	—	—	
7	—	2	3	—	5	—	—	—	—	
7A	1	—	—	—	—	6	7	—	—	
8	—	—	3	—	—	6	7	—	—	
8A	—	—	—	—	5	6	7	—	—	
9	1	—	—	4	—	—	7	—	—	
9A	—	—	3	4	—	—	7	—	—	
10	1	2	—	—	—	—	7	—	—	
10A	—	2	3	—	—	—	7	—	—	
11	—	—	—	4	5	—	7	—	—	
11A	—	2	—	—	5	—	7	—	—	
12*	1	—	3	—	—	—	—	—	9	See note 2
12A*	1	—	—	—	5	—	—	—	9	See note 2
12	1	—	—	—	—	—	—	8	9	
12A	—	—	3	—	—	—	—	8	9	
13	—	—	—	—	5	—	—	8	9	
13A	—	—	—	—	—	—	7	8	9	
14	1	—	—	—	—	6	—	—	9	
14A	—	—	3	—	—	6	—	—	9	
15	—	—	—	—	5	6	—	—	9	
15A	1	—	—	4	—	—	—	—	9	
16	—	—	3	4	—	—	—	—	9	
16A	1	2	—	—	—	—	—	—	9	
17	—	2	3	—	—	—	—	—	9	
17A	—	—	—	4	5	—	—	—	9	
18	—	2	—	—	5	—	—	—	9	
18A	—	—	—	—	—	6	7	—	9	
19	—	—	—	4	—	—	7	—	9	
19A	—	2	—	—	—	—	7	—	9	



Table 6 (continued)

Frame number	Code element									Remarks
	B 1	S 2	B 3	S 4	B 5	S 6	B 7	S 8	B 9	
20*	—	—	3	—	5	—	—	—	9	See note 3 See note 3
20A*	1	—	—	—	—	—	7	—	9	
20	1	—	—	—	—	6	—	8	—	See note 4 See note 4
20A	—	—	3	—	—	6	—	8	—	
21	—	—	—	—	5	6	—	8	—	
21A	1	—	—	4	—	—	—	8	—	
22	—	—	3	4	—	—	—	8	—	
22A	1	2	—	—	—	—	—	8	—	
23	—	2	3	—	—	—	—	8	—	
23A	—	—	—	4	5	—	—	8	—	
24*	—	—	3	—	—	—	7	—	9	
24A*	—	—	—	—	5	—	7	—	9	
24	—	2	—	—	5	—	—	8	—	
24A	—	—	—	—	—	6	7	8	—	
25	—	—	—	4	—	—	7	8	—	
25A	—	2	—	—	—	—	7	8	—	
26	1	—	—	4	—	6	—	—	—	
26A	—	—	3	4	—	6	—	—	—	
27	1	2	—	—	—	6	—	—	—	
27A	—	2	3	—	—	6	—	—	—	
28	—	—	—	4	5	6	—	—	—	
28A	—	2	—	—	5	6	—	—	—	
29	1	2	—	4	—	—	—	—	—	
29A	—	2	3	4	—	—	—	—	—	
30	—	2	—	4	5	—	—	—	—	
30A	—	—	—	4	—	6	7	—	—	
31	—	2	—	—	—	6	7	—	—	
31A	—	2	—	4	—	—	7	—	—	
32	—	—	—	—	—	6	—	8	9	
32A	—	—	—	4	—	—	—	8	9	
33	—	2	—	—	—	—	—	8	9	
33A	—	—	—	4	—	6	—	—	9	
34	—	2	—	—	—	6	—	—	9	
34A	—	2	—	4	—	—	—	—	9	
35	1	—	3	—	5	—	—	—	—	
35A	1	—	3	—	—	—	7	—	—	
36	1	—	—	—	5	—	7	—	—	
36A	—	—	3	—	5	—	7	—	—	
E	—	2	—	4	—	6	—	—	—	See note 5

NOTE 1 Frame-number bar-codes for frames 00, 00A, 0 and 0A should print only if the eye-readable frame number is printed. Frame number 1 is the first mandated number [see Figure 1a)].

NOTE 2 For the last full and half-frame numbers on a 12-exposure roll, use special codes 12\* and 12A\*.

NOTE 3 For the last full and half-frame numbers on a 20-exposure roll, use special codes 20\* and 20A\*.

NOTE 4 For the last full and half-frame numbers on a 24-exposure roll, use special codes 24\* and 24A\*.

NOTE 5 Special end of roll sequence.

### 8 Magazine dimensions

Magazine dimensions shall conform to those shown in Figure 4 and given in Table 7.

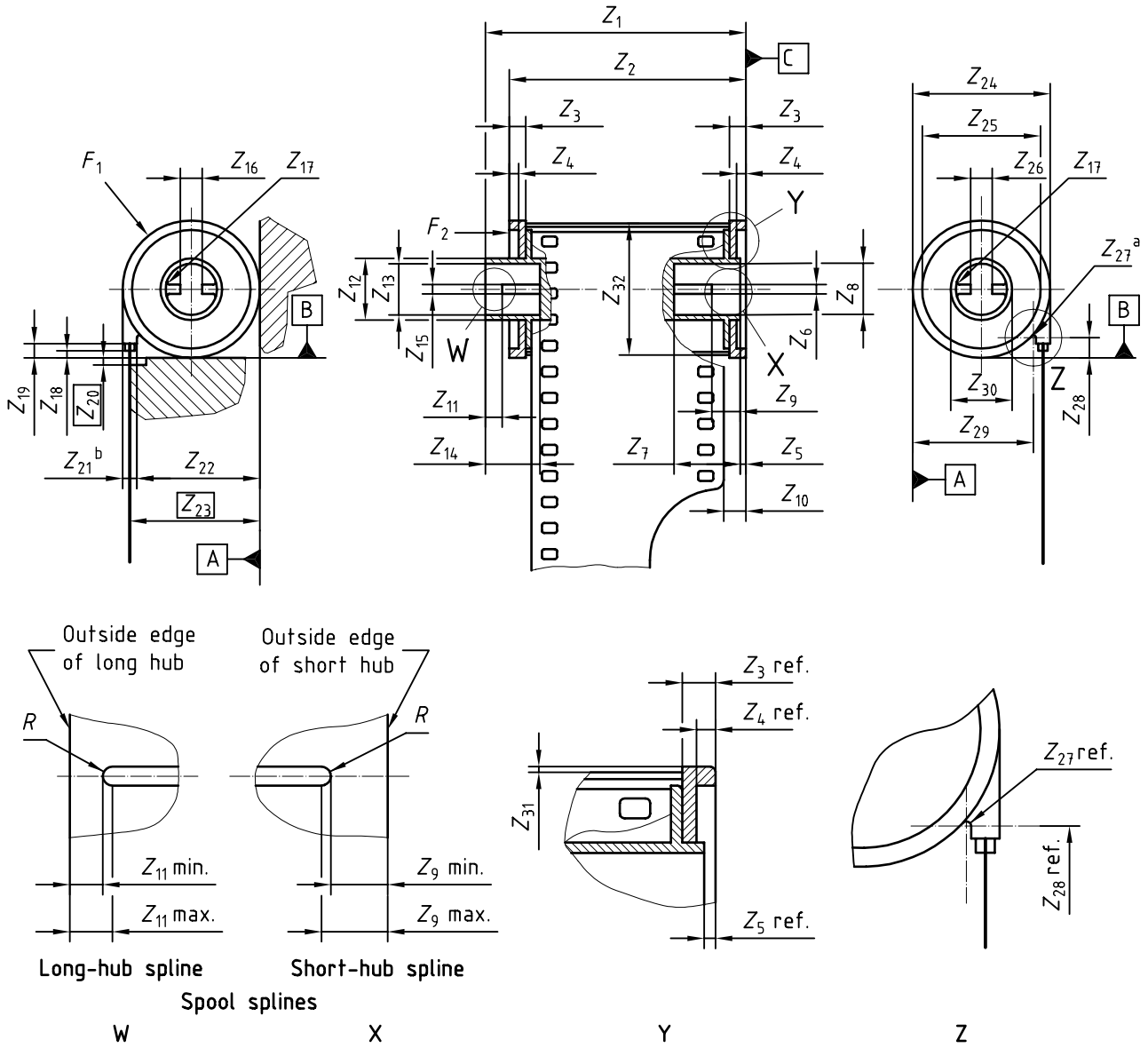

- a See note 7 of Table 7.
- b See note 4 of Table 7.

Figure 4 — 135-size film magazine (see Table 7)

Table 7 — Dimensions of 135-size film magazine (see Figure 4)

Dimensions in millimetres, forces in newtons

Symbol	Minimum	Basic	Nominal	Maximum	Remarks
<b>Dimension</b>					
$Z_1$	46,89			48,00	a
$Z_2$	42,39			43,80	
$Z_3$	—			3,30	
$Z_4$	0,28			—	
$Z_5$	0,79			1,55	a
$Z_6$	1,00			2,06	
$Z_7$	9,65			—	
$Z_8$	9,19			—	
$Z_9$	4,00			5,56	b
$Z_{10}$	2,80			5,10	a
$Z_{11}$	2,01			3,91	b
$Z_{12}$	—			11,40	
$Z_{13}$	9,19			—	
$Z_{14}$	10,00			—	
$Z_{15}$	—			2,11	
$Z_{16}$	0,00			1,50	c
$Z_{17}$	—			0,41	
$Z_{18}$	- 0,51			3,59	d
$Z_{19}$	1,39			3,59	d
$Z_{20}$	—	1,27		—	
$Z_{21}$	—			3,53	d
$Z_{22}$	21,49			—	
$Z_{23}$	—	23,4		—	e
$Z_{24}$	24,89			25,30	f
$Z_{25}$	18,19			—	
$Z_{26}$	4,50			5,00	
$Z_{27}$	—		1	—	g
$Z_{28}$	—		1,5	—	g
$Z_{29}$	—		20,50	—	g
$Z_{30}$	11,51			—	
$Z_{31}$	0,00			0,90	
$Z_{32}$	23,40			—	
Spool float (SF)	0,03			1,00	h
$Z_1 + SF$	47,15			48,05	i
$Z_1 - Z_{11}$	43,11			—	i
$Z_1 - Z_{11} + SF$	—			45,78	i
$Z_1 - Z_{14}$	14,87			—	i
$Z_1 - Z_{14} + SF$	—			36,50	i
$Z_5 + Z_7$	11,30			—	i
$Z_5 + Z_7 + SF$	11,62			—	i
$Z_5 + Z_9$	5,18			—	i
$Z_5 + Z_9 + SF$	—			7,16	i

Table 7 (continued)

Dimensions in millimetres, forces in newtons

Symbol	Minimum	Basic	Nominal	Maximum	Remarks
<b>Force</b>					
$F_1$	—		4	—	j
$F_2$	—		4	—	j

a Dimensions  $Z_1$ ,  $Z_5$ , and  $Z_{10}$  minimum shall be measured when the magazine and spool are assembled and the spool is pushed so that the short-hub end is against the magazine end; that is toward the short-hub end.  $Z_{10}$  max. applies when the spool is forced against the long-hub end of the magazine. The spool shall "float" axially within the magazine, so that the film is capable of exiting the magazine at  $Z_{10} = 3,79$  mm without significant buckling or deformation in the focal plane.

b In order to facilitate engagement with the camera key, the ends of the spool splines may be rounded. However, such rounding should be accomplished within the maximums and minimums established for  $Z_9$  and  $Z_{11}$ .

c The rewind splines in the short-hub end of the spool may be either a solid or a split spline with the two members separated by the distance  $Z_{16}$ .

d The tangent lip of DX magazines shall be oriented parallel to the A datum plane to assure proper angular orientation within the camera. This is preferred (but not mandatory) for non-DX magazines.  $Z_{18}$  is below the B datum plane and for this reason is expressed as a minus value.

e Dimensions  $Z_{23}$  is measured to the face of a gauge block that contacts the emulsion side of the film. In practice, the magazine exit slot should be designed to present the film at this dimension. In no case shall the film be presented less than 22,50 mm from the A datum plane by the time the film reaches the exposure gate of the camera.

f Dimension  $Z_{24}$  needs to be observed strictly only at both ends of the magazine, in order to guarantee a radial guidance inside the camera. In the other area of the magazine wall, a smaller dimension, limited by  $Z_{32}$ , is allowed. The perimeter of the end cap shall have no sharp features that might damage the CAS probes of the camera during loading; bottom loading cameras are especially vulnerable.

g Radius  $Z_{27}$  can only be specified in terms of the maximum profile where the centre of this radius is at  $Z_{28} = 1,50$  mm,  $Z_{29} = 20,50$  mm, and  $Z_{27} = 1,00$  mm. These values, together with  $Z_{22}$  min. and  $Z_{24}$  max., are the dimensions for the hole in the profile gauge for checking magazines.

h The term "spool axial float" applies to any given magazine. It is the distance that the spool can move when it is forced first against one end cap and then against the other.

i The tolerance on this combination of dimensions is less than the sum of the tolerances on the individual dimensions to assure proper interface with the camera. Combination dimensions that include spool axial float (SF) are taken with the spool forced against the long-hub end of the magazine; those without SF are made with the spool forced in the opposite direction.

j Forces  $F_1$  and  $F_2$  describe sufficient forces necessary to hold the magazine against a measuring fixture when the magazine is positioned by  $\overline{A-B|C}$ . The line between the B and the letter C should be perpendicular.

## 9 Magazine bar-code

The magazine bar-code is a machine-readable, interleaved 2-of-5 bar-code pattern that provides a unique product identification number (mathematically related to the combination of part 1 and part 2 DX numbers), as well as a code that describes the number of full-frame exposures contained within the magazine. This information can be helpful to photofinishers in presort operations.

### 9.1 Magazine bar-code dimensions

The magazine bar-code shall conform to the locations and dimensions shown in Figure 3 and given in Table 8. The bar height is specified by dimensions  $W_5$  and  $W_6$ ; the total bar-code width is specified by dimension  $W_4$ .

Quiet zones ( $W_8$ ) shall be provided on both sides of the bar-code as shown in Figure 3. The quiet zone is the area immediately preceding the start character and the area following the stop character. The quiet zones shall contain no markings.

The human-readable interpretation of the bar-code shall be located between the lip of the magazine and the edge of the magazine bar-code. It shall be nominally centred on the bar-code.

**Table 8 — Dimensions of 135-size magazine bar-code (see Figure 3)**

Symbol	Minimum	Basic or nominal	Maximum
<b>Dimension</b>			
$W_1^a$	—	23,4 mm basic	—
$W_2$	—	1,27 mm basic	—
$W_3$	9,40 mm		13,21 mm
$W_4$	—		20,80 mm
$W_5^b$	294°		—
$W_6^b$	—		257°
$W_7^c$	12,45 mm		12,65 mm
$W_8$	3,3 mm		—
<b>Force</b>			
$F_1^d$	—	4 N nominal	—
$F_2^d$	—	4 N nominal	—
<b>Bar/space width <sup>e</sup></b>	<b>Minimum</b>	<b>Aim</b>	<b>Maximum</b>
Narrow	0,25 mm	0,33 mm	0,41 mm
Wide	0,91 mm	0,99 mm	1,07 mm
NOTE Datum plane G is parallel to datum plane B and coincides with the centreline of the magazine.			
a Measured from datum plane A to the sensitized side of the film.			
b Dimensions $W_5$ and $W_6$ define the height of the magazine bar-code.			
c $W_7 = Z_{24}$ divided by 2 (see Figure 4).			
d Forces $F_1$ and $F_2$ describe sufficient forces necessary to hold the magazine and film against a measuring fixture when the magazine is positioned by $\overline{A-B C}$ .			
e Nominal ratio of wide to narrow elements equals 3,00.			

## 9.2 Bar-code reflectance requirements

Reflectance of the bar-code spaces shall be a minimum of 35 %.

The maximum allowable reflectance of the dark bars is related to the reflectance of the bar code spaces and should be calculated from the following:

$$R_D = \frac{R_L}{4}$$

where

$R_D$  is the maximum bar reflectance;

$R_L$  is the space reflectance.

### 9.3 Bar-code identification system

The bar-code provides six digits of information that identify the film and provide encodement of the number of exposures in the magazine.

Digit 1 is assigned at the discretion of the manufacturer. If the manufacturer does not wish to use digit 1 for its own purpose, 0 shall be encoded.

Digits 2 to 5 yield a four-digit number which is encoded on the magazine. This number is calculated from the DX number. First, the part 1 DX number is multiplied by 16; next, that number is added to the part 2 DX number; and then, the resulting four-digit number is encoded in digits 2 to 5.

Digit 6 is a numerical equivalent that is assigned to correlate with the number of exposures (see Table 9).

**Table 9 — Magazine bar-code: Assignment for number of exposures (digit 6)**

Numerical equivalent	Number of exposures
0	1 → 8
1	12
2	18 → 23
3	24
4	36
5	9 → 11
6	13 → 17
7	25 → 29
8	30 → 35
9	37 or more <sup>a</sup>

<sup>a</sup> A long-size film of 37 or more exposures may not be accepted by certain film processors.

## 10 Camera auto-sensing areas

Camera auto-sensing utilizes a set of electrical probes, in appropriately designed 135-size cameras, that contact a pattern of conductive or insulated areas on the magazine. The arrangement of these areas provides an electrically readable encodement of film speed, number of exposures, and recommended exposure latitude.

### 10.1 Dimensions

The dimensions of the camera auto-sensing areas and the limits of the camera probe locations shall conform to the values shown in Figure 5 and given in Table 10. The areas limiting probe locations ( $X_7 \times X_{14}$ ) are much smaller than the sensing areas on the magazine. This allows for variations in the following:

- dimensions of the magazine chamber in the camera;
- dimensions of magazines from different manufacturers;
- alternative systems of seating magazines in different cameras.

Without this factor of safety, it would be possible for a probe to read the wrong block in the camera auto-sensing (CAS) area.

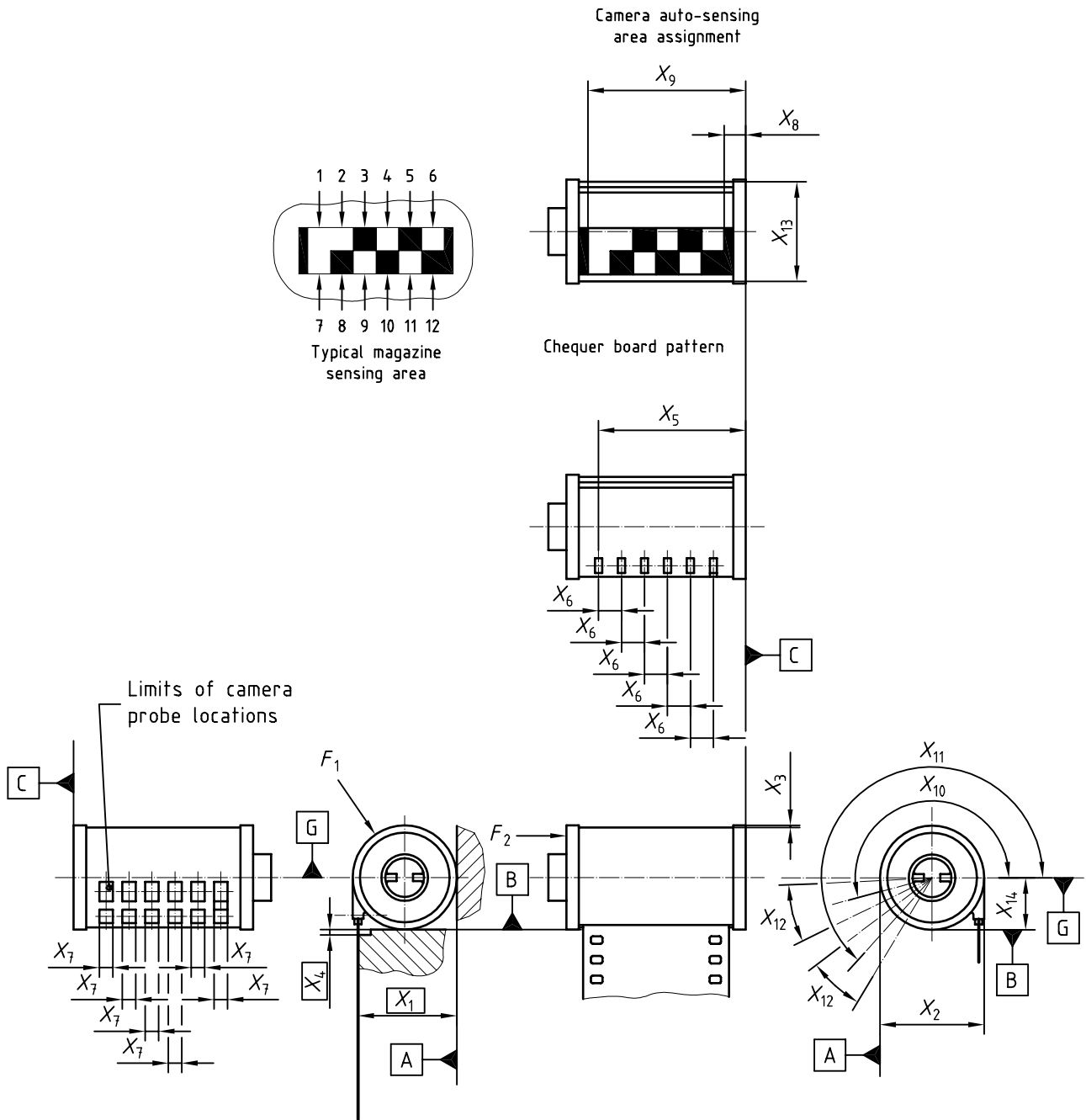

Figure 5 — 135-size camera auto-sensing areas (see Table 10)

**Table 10 — Dimensions of 135-size camera auto-sensing areas** (see Figure 5)

Symbol	Minimum mm	Basic or nominal	Maximum	Remarks
$X_1$		23,4 mm basic		Measured from datum plane A to the sensitized side of the film
$X_2$	24,89		25,30 mm	Measured at both ends of the magazine (see note 1)
$X_3$	0,0		0,9 mm	See notes 1 and 2
$X_4$		1,27 mm basic		
$X_5$		35,50 mm basic		See note 3
$X_6$		5,51 mm basic		See note 3
$X_7$	—		3,12 mm	<sup>a</sup>
$X_8$	—		6,4 mm	
$X_9$	37,06		—	
$X_{10}$		191,7° basic		See note 3
$X_{11}$		225,6° basic		See note 3
$X_{12}$	—		22,7°	<sup>a</sup>
$X_{13}$	23,4		—	See note 1
$X_{14}$	12,45		12,65 mm	See note 4
Force $F_1$		4 N nominal		See note 5
Force $F_2$		4 N nominal		See note 5

NOTE 1 Dimensions  $X_2$ ,  $X_3$  and  $X_{13}$  are specified independently to allow for possible eccentricity between the slot in the magazine end cap and the perimeter of the end cap.

NOTE 2 Dimension  $X_3$  describes the maximum recess of the camera auto-sensing area, when measured from a plane defined by the magazine end cap points of contact.

NOTE 3 Dimensions  $X_5$ ,  $X_6$ ,  $X_{10}$  and  $X_{11}$  describe the theoretical centres of the camera probe locations that coincide with the centres of the CAS areas on the magazine.

NOTE 4  $X_{14} = X_2$  divided by 2.

NOTE 5  $F_1$  and  $F_2$  describe sufficient forces necessary to hold the magazine against a measuring fixture, when the magazine is positioned by A-B|C.

<sup>a</sup> Dimensions  $X_7$  and  $X_{12}$  describe the maximum permissible interface area within which camera contacts shall be confined. CAS area numbers 1 and 7 shall form a single continuous area. All CAS areas shall be printed significantly larger, as shown in the sketch “typical magazine sensing area” in Figure 5 because of magazine manufacturing variability. The practical size of each CAS area approximates a rectangle with edges equal to  $X_6$  in width and  $(X_{11} - X_{10})$  in arc. The basic position of the borderline between individual CAS blocks is midway between the adjacent CAS area centres. For the position of the CAS area centres on the magazine surface, see note 3.

## 10.2 Location and code assignments

Location and code assignments shall conform to the values shown in Figure 5 by the view identified as “typical magazine sensing area” and are given in Tables 10 to 13. In each table, a number under the sensing area represents a conducting area; a dash (—) represents an insulated area.

Areas numbered 1 and 7 are common/return contact areas. Sensing areas 2 to 6 encode the ISO speed or manufacturer’s recommended exposure index, as given in Table 11. Sensing areas 8 to 10 encode the number of exposures, as given in Table 12. Sensing areas 11 and 12 encode exposure latitude of the film, as given in Table 13.



### 10.3 DC electrical characteristics

Conductive areas are defined by the potential drop ( $V_{OL}$ ) across the series combination of the common contacts and any other contact.

Insulated areas are defined by the insulation resistance ( $R_I$ ). The insulation resistance is calculated from:

$$R_I = \frac{V_{OL}}{I_{DC}}$$

where  $I_{DC}$  is the measured current through the contact series combination of the common contacts and any other contact (see B.3 of informative annex B).

**Table 11 — Auto-sensing areas: Code for ISO speed/exposure index**

ISO speed or exposure index		Sensing area				
Arithmetic	Logarithmic	2	3	4	5	6
a		—	—	—	—	—
25	15	—	—	—	5	—
32	16	—	—	—	—	6
40	17	—	—	—	5	6
50	18	2	—	—	5	—
64	19	2	—	—	—	6
80	20	2	—	—	5	6
100	21	—	3	—	5	—
125	22	—	3	—	—	6
160	23	—	3	—	5	6
200	24	2	3	—	5	—
250	25	2	3	—	—	6
320	26	2	3	—	5	6
400	27	—	—	4	5	—
500	28	—	—	4	—	6
640	29	—	—	4	5	6
800	30	2	—	4	5	—
1 000	31	2	—	4	—	6
1 250	32	2	—	4	5	6
1 600	33	—	3	4	5	—
2 000	34	—	3	4	—	6
2 500	35	—	3	4	5	6
3 200	36	2	3	4	5	—
4 000	37	2	3	4	—	6
5 000	38	2	3	4	5	6

<sup>a</sup> Magazine is not encoded with the ISO speed/exposure index.

**Table 12 — Auto-sensing areas: Code for number of exposures**

Decimal equivalent	Number of exposures	Sensing area		
		8	9	10
a	—	—	—	—
1	12	8	—	—
3	24	8	9	—
4	36	—	—	10

NOTE 20-exposure film length was previously a standard size. Decimal equivalent number 2 was assigned to 20 exposures and utilized sensing area 9 only. The reader should take care not to use sensing area 9 only because existing cameras may still be designed to understand that this encodement equals 20 exposures only.

<sup>a</sup> Any non-standard lengths.

**Table 13 — Auto-sensing areas: Code for exposure latitude**

Exposure latitude (stops)	Sensing area	
	11	12
$\pm 1/2$	—	—
$\pm 1$	11	—
+ 2, - 1	—	12
+ 3, - 1	11	12

## 11 Magazine information panel

The information-panel area displays key information about the film contained within the magazine. It is visible through a window in the back of any appropriately designed camera.

### 11.1 Location and dimensions

The information-panel area shall be located on the magazine's outer surface and shall conform to the dimensions shown in Figure 6 and given in Table 14.

### 11.2 Contents of the information panel

The human-readable data located within the information panel shall contain the following:

- film identification;
- ISO speed or manufacturer's recommended exposure index;
- number of exposures.

NOTE Sometimes, the ISO speed or exposure index is included as part of the film identification (film name) and need not be repeated. ISO 6, ISO 2240, and ISO 5800 (see [3], [5], [6] in the Bibliography) provide methods for determining the ISO speed of various film products.

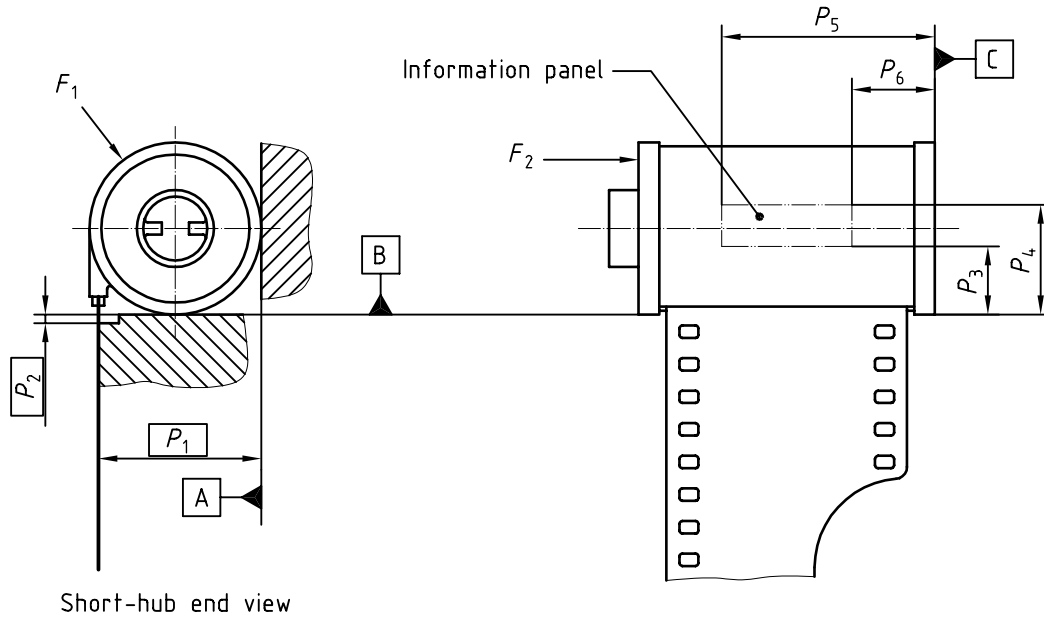

Figure 6 — 135-size magazine information panel (see Table 14)

Table 14 — Dimensions of 135-size magazine information panel (see Figure 6)

Symbol	Minimum	Basic or nominal	Maximum
$P_1^a$		23,4 mm basic	
$P_2$		1,27 mm basic	
$P_3$	12 mm		—
$P_4$	—		16 mm
$P_5$	—		31 mm
$P_6$	14 mm		—
Force $F_1^b$		4 N nominal	
Force $F_2^b$		4 N nominal	

<sup>a</sup> Measured from datum A to the sensitized side of the film.

<sup>b</sup>  $F_1$  and  $F_2$  describe sufficient forces necessary to hold the magazine against a measuring fixture when the magazine is positioned A-B|C.

## 12 Process identification

The magazine graphics shall include a specific visual reference to the type of process for which the film is intended.

## 13 Film pull-out force

To begin pulling the film out of the magazine lip, the initial force shall be a maximum of 5,0 N. After 100 mm of film has been extracted from the magazine, the force to again begin pulling the film from the magazine shall be a maximum of 2,5 N and shall not exceed 2,5 N at any point throughout the roll.

These specifications apply both at the time of manufacture and throughout the manufacturer's specified product life when the film is stored according to the manufacturer's recommendations.

Various methods of measuring the force required to pull the film from the magazine are in use by manufacturers. Several of these methods provide a continuous record or scale reading of the actual force required as the film is drawn from the magazine. However, for the purposes of this International Standard, it is only necessary to determine whether the force required to pull the film from the magazine is less than the specified values. See B.4 of annex B for a description of one method for testing this.

#### **14 Film-spool attachment strength**

A pulling force of 40 N on the film shall not break the film-spool attachment. This 40 N specification applies both at the time of manufacture as well as throughout the manufacturer's specified product life when stored according to the manufacturer's recommendations.

## Annex A (normative)

### Assignment of DX numbers

#### A.1 General

This annex defines the procedure by which film sensitizers shall request assignment of part 1 DX numbers for 135-size films and magazines. It also describes the procedures by which the Photographic & Imaging Manufacturers Association, Inc. (PIMA) assigns part 1 DX numbers and generates annual reports about the status of the programme.

Also included is a description of a new system for supplementing the magazine bar-code to provide additional product information for photofinishers (see A.4).

#### A.2 Terms, definitions and acronyms

The following terms, definitions and acronyms apply.

##### A.2.1 Terms and definitions

###### A.2.1.1

###### **sensitizer**

manufacturer that coats photographic emulsion on film base

###### A.2.1.2

###### **converter**

general term for companies that may perform various operations to sensitized film, including the addition of DX codes to the 135 magazine and film

##### A.2.2 Acronyms

###### A.2.2.1

###### **CAS**

camera auto-sensing (code)

###### A.2.2.2

###### **LIBC**

latent-image bar-code

###### A.2.2.3

###### **MBC**

magazine bar-code

#### A.3 Code assignment

**A.3.1** PIMA administers the DX program, assigns part 1 DX numbers to sensitizers, and provides information and guidance to participants. At present, the available part 1 DX numbers range from 0 (zero) to 127.

**A.3.2** PIMA maintains records of sensitizers, their addresses, the names of individuals authorized to request DX numbers, and the part 1 numbers assigned to them.

## ISO 1007:2000(E)

**A.3.3** Part 1 numbers identify the sensitizer. All films assigned to a given part 1 number should be of the same process, e.g. colour negative, colour reversal, black and white, etc.

**A.3.4** Part 2 numbers are assigned by sensitizers and form a combination with each part 1 number that provides full identification of a specific product. There are 16 part 2 numbers (zero through 15) for each part 1 number (for example, 83-0, 83-1, 83-2, ..., 83-15).

It is the combination of the part 1 and part 2 numbers, together with the requirements given in this International Standard, that determine the actual bar-codes used on the product.

**A.3.5** When a new product is introduced, the sensitizer shall report to PIMA the product name and the assigned two-part number.

PIMA records this information and issues a report annually. The report shall include the percent of part 1 codes assigned to sensitizers, each sensitizer's company name, and a summary of the part 1/part 2 combination numbers, including the product names being used by each sensitizer.

**A.3.6** All sensitizers shall confirm their intent to retain assigned part 1 DX numbers 36 months after the issuance dates.

**A.3.7** Film converters that want a two-part DX number shall request this information from the sensitizer. PIMA shall not assign DX numbers to converters.

**A.3.8** A sensitizer may assign a number of products to a single DX number. In such cases, all products shall be of the same process, e.g. colour negative, or black and white.

It is preferred that a sensitizer not assign more than one combination DX number to a single film.

### A.4 Expanded capacity of the magazine bar-code

The capacity of the magazine bar-code (MBC) system has been expanded by the method outlined below. This has been done to enlarge the utility of the MBC in photofinishing operations by permitting additional differentiation of product characteristics. The method also ensures that PIMA can maintain adequate control over the allocation of DX numbers and circumvents the danger of different sensitizers using the same magazine bar-code for different types of information.

As noted, the total number of available part 1 DX numbers is 128 (0 through 127). This limit is imposed by the restricted number of bits in the latent image bar-code (LIBC). However, the magazine bar-code can be expanded by supplementing each part 1 DX number in increments of 128, up to and including number 511. For example, part 1 DX number 83 can be supplemented with numbers 211 ( $83 + 128$ ); 339 ( $83 + 128 + 128$ ); and 467 ( $83 + 128 + 128 + 128$ ).

These "incremental" numbers have been added to the basic part 1 DX numbers assigned to sensitizers. They can be used to differentiate magazines without impact on the LIBC, but there is no obligation to use or renew them. [Only the basic part 1 DX numbers (0 through 127) must be renewed, see A.3.6 ]. However, when augmented magazine bar-code numbers are used by a sensitizer, full information about affected products should be sent to PIMA for record keeping and incorporation in its annual report.

## A.5 Procedure for DX number assignment

A sensitizer shall send a written request to PIMA for the assignment of part 1 DX numbers. Such letters, fax's or e-mail correspondence should be addressed to:

Photographic & Imaging Manufacturers Association, Inc.  
550 Mamaroneck Avenue, Suite 307  
Harrison, New York 10528-1612    EMAIL: natlstds@pima.net

The name and address of the sensitizer shall be documented on the request letter, as well as the name of the person authorized to request DX numbers, the phone and FAX numbers, and the e-mail address where appropriate.

The sensitizer may request a specific part 1 DX number. If the specific number is available, it will be assigned; if it is not available, PIMA shall assign an alternative number.

All assignments shall be confirmed in writing by PIMA to the authorized requestor.

## Annex B (informative)

### Methods for measurement of key characteristics

#### B.1 General

This annex describes methods for measuring the following important attributes of 135-size films and magazines:

- density and element width of latent-image digital bar-codes;
- DC electrical characteristics of camera auto-sensing areas;
- film pull-out force;
- film-spool attachment strength;
- magazine bar-codes.

#### B.2 Measurement of density and element width of latent-image digital bar-codes

The required dimensions and optical densities of the bar-code elements imaged along the edges of processed 135-size colour negative films are specified in Table 1 and 7.3 respectively.

Verification of the density values is generally done with a scanning densitometer. This instrument should have an effective aperture of 0,05 mm or less and should be capable of measuring status M red diffuse transmission densities  $D_T$  with an accuracy of  $\pm 0,02$ . An option to read out the corresponding transmittance ( $T$ ) values is useful, but these can be converted easily from the density values ( $D_T = \log_{10} 1/T$ ).

When a data track is to be scanned, the centreline of the aperture should be  $0,41 \text{ mm} \pm 0,025 \text{ mm}$  from the film edge. When scanning the clock track, the centreline should be  $1,63 \text{ mm} \pm 0,025 \text{ mm}$  from the film edge. The linear magnification should be such that density changes from bars to spaces can be measured to within  $\pm 0,025 \text{ mm}$  at normal scanning speed.

For this application, the edge of an element is defined as the line that lies halfway between the locus of minimum transmittance of the exposed element (bar) and the locus of maximum transmittance of the adjacent unexposed element (space). The distance between two neighboring edges is the element's width. However, when the effective aperture in the plane of the bar-code image is smaller than 0,03 mm, the corresponding density values can be used instead of the transmittance values to define the half-width locus

#### B.3 Measurement of DC electrical characteristics of camera auto-sensing areas

For testing the electrical characteristics of each camera auto-sensing area on the magazine, including the common/return areas 1 and 7, two identical, independently located probes should be used, that is, redundant contacts.

Each probe should be spherical in shape with a radius of 1,5 mm to 2,5 mm, and have a nickel surface with a hardness of at least 55 HRC. Each probe should have a maximum surface roughness of  $0,3 \mu\text{m}$  CLA. The force urging each probe into contact should be 0,139 N to 0,556 N.



The following specifications are valid for the ranges of open-circuit voltages and limit currents given in 10.3:

- $V_{OL} = 0,7 \text{ V max.}$  (conductive areas)
- $R_1 = 600 \text{ K-ohm min.}$  (insulated areas)

For the test device, the open-current voltage ( $V_{DC}$ ) is 1,5 V min. and 9,0 V max.

Limited current is given by:

$$\frac{V_{DC}}{R_{CL}} = 15 \mu\text{A min. and } 10 \text{ mA max.}$$

where

$V_{DC}$  is the DC voltage used in the power supply of the test circuit;

$R_{CL}$  is the resistance of a current-limiting resistor used to limit the current flow in the test circuit.

NOTE In normal usage by the customer/photographer, relative motion between the CAS areas and the camera contacts may occur. Magazine restraint or smooth camera contact probes, or both, are recommended to minimize potential damage of the insulated and contact areas.

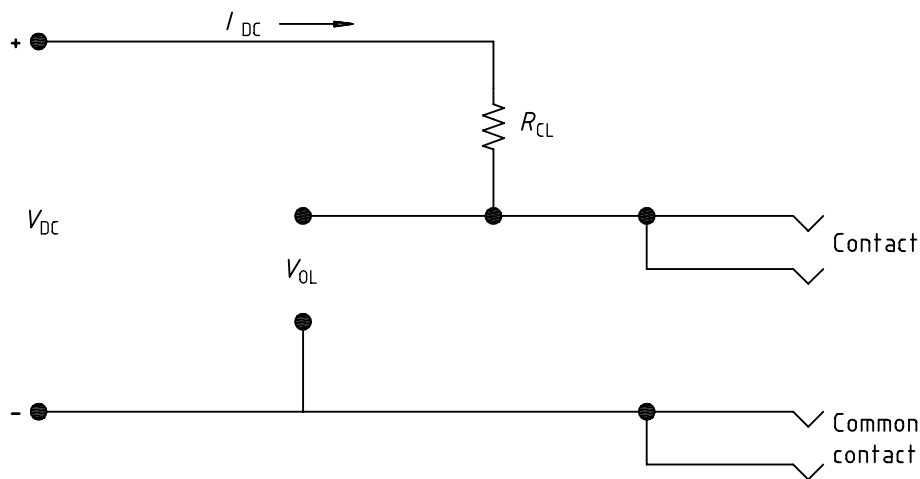

Figure B.1 — DC electrical circuit for camera auto-sensing testing

## B.4 Measurement of film pull-out force

Determination of whether the force required to pull the film from the magazine is less than the maximum values given in this International Standard can be done by inserting a loaded film magazine into a slotted gauge block of such weight that the block will be lifted off its support when the force required to pull the film from the magazine exceeds the specified value.

### B.4.1 Test conditions

For this test, it is recommended that load masses of 0,50 kg and 0,25 kg be used. The mass of the film and magazine are additional to this. The "balance" of the gauge block and the magazine need only be approximate.

The test should be carried out at a relative humidity of  $(50 \pm 10) \%$  and a temperature in the range of 10 °C to 30 °C.

### B.4.2 Procedure

The magazine should first be inserted into the larger load-mass block with the lip vertically upward. It should then be possible to pull the film out of the magazine in a vertical direction without raising the block.

After 100 mm of film has been extracted from the magazine, the magazine should be inserted into the smaller load-mass block. It should be possible to pull the film out of the magazine in a vertical direction without raising the block.

**CAUTION — Requirements for film pull-out forces continue to evolve. Users of this International Standard should take care to understand fully the requirements of modern cameras in addition to the traditional and basic film pull-out force specified in this standard.**

### B.5 Measurement of film-spool attachment strength

The following dynamic method is suggested for measuring the strength of attachment of film to a film spool.

NOTE A static method giving corresponding results may be used.

- a) Film should be attached to a 135-size film spool using the manufacturer's normal method of attachment. Wind the film onto the spool, and place the film and spool in a 135-size magazine.
- b) Condition the sample at 21 °C to 24 °C and at a relative humidity of 48 % to 52 % for 3 days.
- c) Pull the full length of film from the magazine, being careful not to disturb the film-spool attachment.
- d) Remove and discard all but 230 mm of film, measured from the magazine lip.
- e) Rewind 200 mm of the remaining film into the magazine.
- f) Insert the magazine into the holding device of the test instrument.
- g) Attach a tensile tester to the free end of the film. The tester should be set to advance at a rate of 100 mm/min.
- h) Engage the tensile tester to pull the film from the magazine.
- i) Measure the breaking strength of each sample.

The same test can be carried out under more severe temperature and humidity conditions to determine whether or not an adequate attachment strength will be maintained under adverse storage and use conditions.

### B.6 Magazine bar-codes

This clause describes several characteristics of the magazine bar-code that are different from those generally recommended for the interleaved 2-of-5 bar code.

- a) The height of the human-readable characters is generally less than 2,381 mm due to physical constraints of product size.
- b) A smaller bar and space width tolerance of  $\pm 0,076$  mm is used in order to increase first-read rate and reduce the probability of character substitution.
- c) A reduced minimum-space reflectance of 35 % (see 9.2) is typical of lithographic materials used for 135-size magazines.

## Annex C (informative)

### Historical dimensions used to design magazines and cameras

Before the DX system came into use, the primary interface between the camera and film roll was the film itself, that is the film was located on the sprockets and between the rails. The magazine was generally free to move within the camera cavity.

The DX camera auto-sensing areas require first locating the magazine precisely with the camera cavity and then threading the film. Therefore, this edition of ISO 1007 continues to utilize three datum planes and some of the historical dimensions pertaining to film location have been maintained.

Three historical dimensions, shown in Figure C.1, are considered important by some camera manufacturers. The film's flexibility, as well as the constraining action of the magazine light lock, make it extremely difficult to measure and control these dimensions accurately during manufacture. Therefore, they are shown in this annex to aid the reader in the design of magazines and cameras. Manufacturers should design as closely as possible to the dimensions given in Figure C.1.

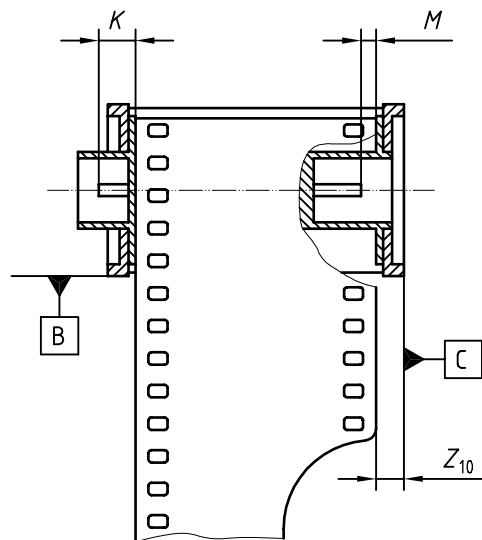

$$— K = 5,60 \text{ mm} \pm 0,70 \text{ mm}$$

$$— M = 2,70 \text{ mm} \begin{matrix} +0,70 \\ -0,69 \end{matrix} \text{ mm}$$

NOTE When the film reaches the camera aperture,  $Z_{10}$  (formerly E) will relate to the film-edge location and should allow the possibility that the film will pass through a width-wise band from 3,69 mm to 3,89 mm from the C datum plane.

Figure C.1 — Magazine design aims

## Bibliography

- [1] AIM USA, *Uniform Symbology Specifications*.
- [2] ISO 5-3:1995, *Photography — Density measurements — Part 3: Spectral conditions*.
- [3] ISO 6:1993, *Photography — Black-and-white pictorial still camera negative film/process systems — Determination of ISO speed*.
- [4] ISO 897:1988, *Photography — Roll films, 126, 110 and 135 size films — Identification of the image-bearing side*.
- [5] ISO 2240:1994, *Photography — Colour reversal camera films — Determination of ISO speed*.
- [6] ISO 5800:1987<sup>1)</sup>, *Photography — Colour negative films for still photography — Determination of ISO speed*.

---

1) To be revised.



---

---

**ICS 37.040.20**

Price based on 38 pages

© ISO 2000 – All rights reserved .....