**Fasteners — Bolts, screws and studs —
Nominal lengths and thread lengths**

*Fixations — Vis, goujons et tiges filetées — Longueurs nominales et
longueurs filetées*



Reference number
ISO 888:2012(E)

© ISO 2012



COPYRIGHT PROTECTED DOCUMENT

© ISO 2012

All rights reserved. Unless otherwise specified, no part of this publication may be reproduced or utilized in any form or by any means, electronic or mechanical, including photocopying and microfilm, without permission in writing from either ISO at the address below or ISO's member body in the country of the requester.

ISO copyright office
Case postale 56 • CH-1211 Geneva 20
Tel. + 41 22 749 01 11
Fax + 41 22 749 09 47
E-mail copyright@iso.org
Web www.iso.org

Published in Switzerland

Contents

Page

Foreword	iv
1 Scope	1
2 Normative references	1
3 Symbols	1
4 Position of lengths and thread lengths	1
4.1 General	1
4.2 Bolts and screws	2
4.3 Headless screws and set screws	3
4.4 Studs and similar fasteners	3
5 Dimensions for lengths	5
6 Dimensions for thread lengths	6

.....

Foreword

ISO (the International Organization for Standardization) is a worldwide federation of national standards bodies (ISO member bodies). The work of preparing International Standards is normally carried out through ISO technical committees. Each member body interested in a subject for which a technical committee has been established has the right to be represented on that committee. International organizations, governmental and non-governmental, in liaison with ISO, also take part in the work. ISO collaborates closely with the International Electrotechnical Commission (IEC) on all matters of electrotechnical standardization.

International Standards are drafted in accordance with the rules given in the ISO/IEC Directives, Part 2.

The main task of technical committees is to prepare International Standards. Draft International Standards adopted by the technical committees are circulated to the member bodies for voting. Publication as an International Standard requires approval by at least 75 % of the member bodies casting a vote.

Attention is drawn to the possibility that some of the elements of this document may be the subject of patent rights. ISO shall not be held responsible for identifying any or all such patent rights.

ISO 888 was prepared by Technical Committee ISO/TC 2, *Fasteners*, Subcommittee SC 7, *Reference standards*.

This second edition cancels and replaces the first edition (ISO 888:1976), which has been technically revised.

iv

Fasteners — Bolts, screws and studs — Nominal lengths and thread lengths

1 Scope

This International Standard specifies lengths and thread lengths for bolts, screws and studs for use in appropriate product standards and other relevant documents, e.g. for parts per drawing.

It applies to bolts, screws and studs with ISO metric screw thread according to ISO 68-1.

2 Normative references

The following referenced documents are indispensable for the application of this document. For dated references, only the edition cited applies. For undated references, the latest edition of the referenced document (including any amendments) applies.

ISO 68-1, *ISO general purpose screw threads — Basic profile — Part 1: Metric screw threads*

ISO 225, *Fasteners — Bolts, screws, studs and nuts — Symbols and descriptions of dimensions*

ISO 4753, *Fasteners — Ends of parts with external ISO metric thread*

ISO 4759-1, *Tolerances for fasteners — Part 1: Bolts, screws, studs and nuts — Product grades A, B and C*

3 Symbols

b	thread length
b_1	thread length of one end for double-end stud
b_2	thread length of the other end for double-end stud
b_m	thread length of the stud metal end
d	basic major diameter (nominal diameter) of the thread
l	nominal length (of the bolt, screw or stud)
l_g	distance from the bearing face to the first full form (full profile) thread (bolt), as specified in ISO 225
l_s	length of the unthreaded shank
P	pitch of the thread

4 Position of lengths and thread lengths

4.1 General

The nominal length, l , and the thread length, b , features for bolts, screws and studs are specified in ISO 225.

Points for bolts and screws are usually included in the length and thread length, except for the pilot point; they are specified in ISO 4753.

4.2 Bolts and screws

For bolts and screws with effective bearing surface perpendicular to the axis, the length shall be defined from the bearing face to the end of the bolt or screw; see Figure 1.

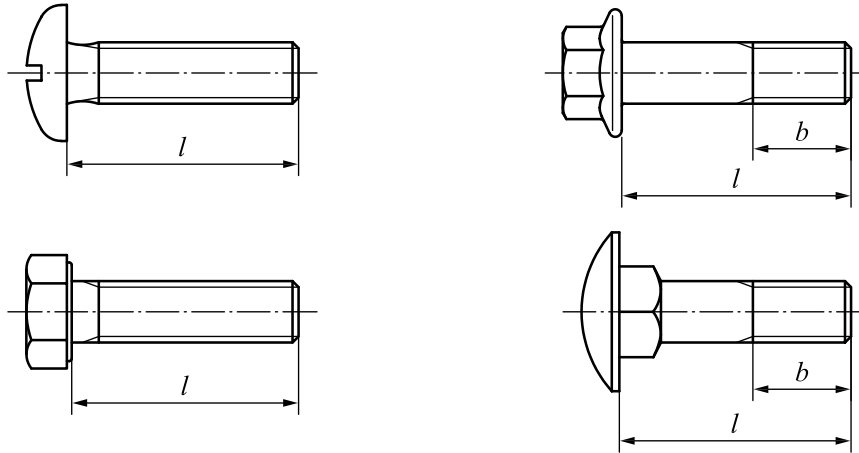

Figure 1 — Length for bolts and screws with effective bearing surface perpendicular to the axis

For flat countersunk bolts and screws, the length shall be defined from the upper edge of the head to the end of the bolt or screw; see Figure 2.

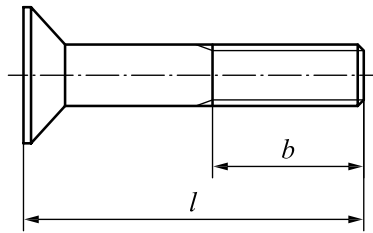

Figure 2 — Length for bolts and screws with flat countersunk head

For raised countersunk bolts and screws, the length shall be defined from the theoretical intersection of the top surface of the head with the head diameter to the end of the bolt or screw; see Figure 3.

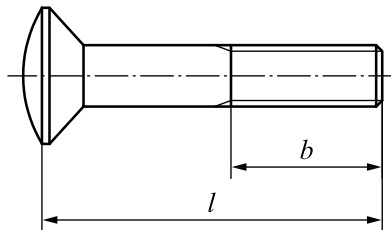

Figure 3 — Length for bolts and screws with raised countersunk head

For concave bearing surfaces, serrated bearing surface and similar, the length shall be defined from the effective bearing plane of the bearing face to the end of the bolt or screw; see Figures 4 and 5.

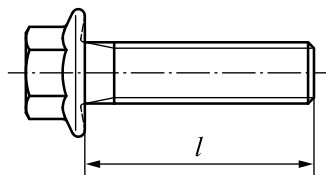

Figure 4 — Length for bolts and screws with concave bearing surface

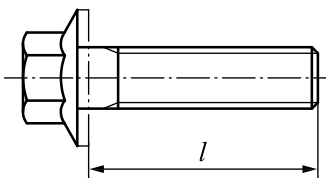

Figure 5 — Length for bolts and screws with serrated bearing surface

4.3 Headless screws and set screws

For headless screws and set screws, the length shall be defined from one extreme end to the other; see Figures 6 and 7.

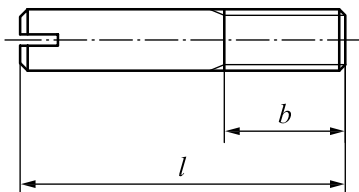

Figure 6 — Length for headless screws with shank

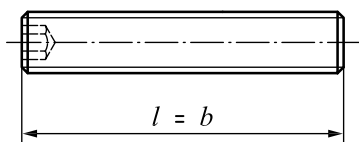
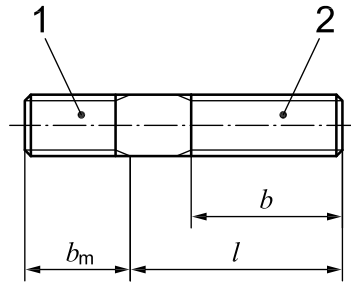

Figure 7 — Length for set screws

4.4 Studs and similar fasteners

For partially threaded studs (double-end studs), the length shall be defined from the thread run-out at the metal end to the end of the stud at the nut end; see Figure 8.

NOTE The thread length of the stud metal end, b_m , according to ISO 225, is not within the scope of this International Standard.



Key

- 1 stud metal end
- 2 nut end

Figure 8 — Length for partially threaded studs (two threaded ends/shanks)

For tie rods (double-end studs with right- and left-hand threads/tensioning studs), for partially threaded studs (single-end stud), for totally threaded studs with points (chamfer or flat) and totally threaded studs (threaded rods/studding), the length shall be defined from one extreme end to the other; see Figures 9 to 12.

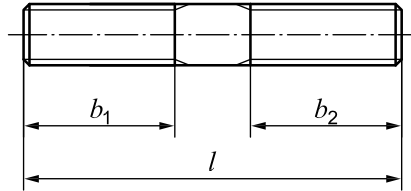

Figure 9 — Length for tie rod

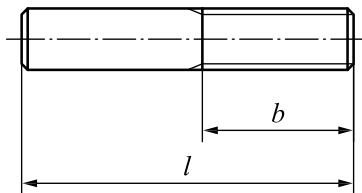

Figure 10 — Length for partially threaded studs (single-end stud)

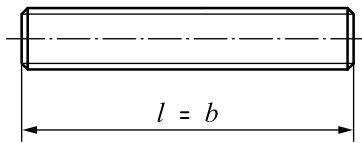

Figure 11 — Length for totally threaded studs (continuous thread)

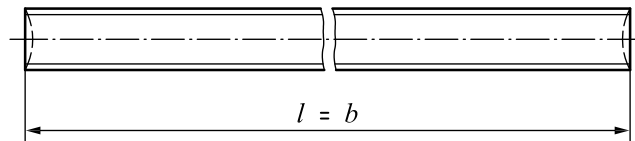

Figure 12 — Length for totally threaded studs (threaded rods)

5 Dimensions for lengths

Dimensions for the lengths are specified in Table 1.

Table 1 — Lengths for ISO metric bolts, screws and studs

Dimensions in millimetres

<i>l</i>	Product grade					
	A		B		C	
	<i>l</i> _{min}	<i>l</i> _{max}	<i>l</i> _{min}	<i>l</i> _{max}	<i>l</i> _{min}	<i>l</i> _{max}
2	1,80	2,20	–	–	–	–
(2,5)	2,30	2,70	–	–	–	–
3	2,80	3,20	–	–	–	–
4	3,76	4,24	–	–	–	–
5	4,76	5,24	–	–	–	–
6	5,76	6,24	–	–	–	–
(7)	6,71	7,29	–	–	–	–
8	7,71	8,29	–	–	–	–
(9)	8,71	9,29	–	–	–	–
10	9,71	10,29	9,25	10,75	9,25	10,75
(11)	10,65	11,35	10,10	11,90	10,10	11,90
12	11,65	12,35	11,10	12,90	11,10	12,90
(14)	13,65	14,35	13,10	14,90	13,10	14,90
16	15,65	16,35	15,10	16,90	15,10	16,90
(18)	17,65	18,35	17,10	18,90	17,10	18,90
20	19,58	20,42	18,95	21,05	18,95	21,05
(22)	21,58	22,42	20,95	23,05	20,95	23,05
25	24,58	25,42	23,95	26,05	23,95	26,05
(28)	27,58	28,42	26,95	29,05	26,95	29,05
30	29,58	30,42	28,95	31,05	28,95	31,05
(32)	31,50	32,50	30,75	33,25	30,75	33,25
35	34,50	35,50	33,75	36,25	33,75	36,25
(38)	37,50	38,50	36,75	39,25	36,75	39,25
40	39,50	40,50	38,75	41,25	38,75	41,25
45	44,50	45,50	43,75	46,25	43,75	46,25
50	49,50	50,50	48,75	51,25	48,75	51,25
55	54,40	55,60	53,50	56,50	53,50	56,50
60	59,40	60,60	58,50	61,50	58,50	61,50
65	64,40	65,60	63,50	66,50	63,50	66,50
70	69,40	70,60	68,50	71,50	68,50	71,50
(75)	74,40	75,60	73,50	76,50	73,50	76,50
80	79,40	80,60	78,50	81,50	78,50	81,50
(85)	84,30	85,70	83,25	86,75	83,25	86,75
90	89,30	90,70	88,25	91,75	88,25	91,75
(95)	94,30	95,70	93,25	96,75	93,25	96,75
100	99,30	100,70	98,25	101,75	98,25	101,75
(105)	104,30	105,70	103,25	106,75	103,25	106,75
110	109,30	110,70	108,25	111,75	108,25	111,75
(115)	114,30	115,70	113,25	116,75	113,25	116,75
120	119,30	120,70	118,25	121,75	118,25	121,75
(125)	124,20	125,80	123,00	127,00	123,00	127,00
130	129,20	130,80	128,00	132,00	128,00	132,00
140	139,20	140,80	138,00	142,00	138,00	142,00
150	149,20	150,80	148,00	152,00	148,00	152,00
160	159,20	160,80	158,00	162,00	156,00	164,00
(170)	169,20	170,80	168,00	172,00	166,00	174,00
180	179,20	180,80	178,00	182,00	176,00	184,00
(190)	189,10	190,90	187,70	192,30	185,40	194,60
200	199,10	200,90	197,70	202,30	195,40	204,60
220	219,10	220,90	217,70	222,30	215,40	224,60
240	239,10	240,90	237,70	242,30	235,40	244,60
260	–	–	257,40	262,60	254,80	265,20
280	–	–	277,40	282,60	274,80	285,20
300	–	–	297,40	302,60	294,80	305,20
320	–	–	317,15	322,85	314,30	325,70
340	–	–	337,15	342,85	334,30	345,70
360	–	–	357,15	362,85	354,30	365,70
380	–	–	377,15	382,85	374,30	385,70
400	–	–	397,15	402,85	394,30	405,70
420	–	–	416,85	423,15	413,70	426,30
440	–	–	436,85	443,15	433,70	446,30
460	–	–	456,85	463,15	453,70	466,30
480	–	–	476,85	483,15	473,70	486,30
500	–	–	496,85	503,15	493,70	506,30

Nominal lengths in parentheses (brackets) should be avoided, if possible.

Tolerances for length are calculated in accordance with ISO 4759-1.

6 Dimensions for thread lengths

Unless otherwise specified in a product standard, dimensions for thread lengths, b (see Table 2), shall be calculated as follows:

- for $l \leq 125$ mm: $b = 2d + 6$ mm
- for $125 \text{ mm} < l \leq 200$ mm: $b = 2d + 12$ mm
- for $l > 200$ mm: $b = 2d + 25$ mm

When the calculation for shorter bolts results in a shank (unthreaded portion) of length $\leq 0,5d$, the bolt should be fully threaded.

Table 2 — Thread lengths for ISO metric bolts, screws and studs

Dimensions in millimetres

Thread diameter		1,6	2	2,5	3	4	5	6	8	10	12	(14)	16	18	20	22
d																
Thread length b	$l \leq 125$	9	10	11	12	14	16	18	22	26	30	34	38	42	46	50
	$125 < l \leq 200$	—	—	—	—	—	—	—	28	32	36	40	44	48	52	56
	$l > 200$	—	—	—	—	—	—	—	—	—	—	—	57	61	65	69

Thread diameter		24	27	30	33	36	39	42	45	48	52	56	60	64	68	72
d																
Thread length b	$l \leq 125$	54	60	66	72	78	84	90	96	102	—	—	—	—	—	—
	$125 < l \leq 200$	60	66	72	78	84	90	96	102	108	116	124	132	140	148	156
	$l > 200$	73	79	85	91	97	103	109	115	121	129	137	145	153	161	169

Thread diameter		76	80	85	90	95	100	105	110	115	120	125	130	140	150	160
d																
Thread length b	$l \leq 125$	—	—	—	—	—	—	—	—	—	—	—	—	—	—	—
	$125 < l \leq 200$	164	172	182	192	—	—	—	—	—	—	—	—	—	—	—
	$l > 200$	177	185	195	205	215	225	235	245	255	265	275	285	305	325	345

Tolerances for thread lengths are specified in ISO 4759-1 as follows:

- a) for bolts and screws with drives (e.g. hexagon head, hexagon head with flange, hexagon socket head cap, hexalobular cylindrical head, cup head square neck, hexagon or hexalobular countersunk head bolts and similar bolts specified in ISO 225), the tolerances are expressed in terms of l_g and l_s , and are specified in product standards according to the following:
 - $l_{g,max} = l_{nom} - b$
 - $l_{s,min} = l_{g,max} - 5P$
- b) for slotted or recessed screws and similar screws (e.g. pan head, cheese head, countersunk head specified in ISO 225) and studs, the tolerance for b is $^{+2P}_0$.

ICS 21.060.10

Price based on 6 pages