

INTERNATIONAL STANDARD

ISO 732

Fourth edition
2000-11-01

Photography — 120-size and 220-size films — Dimensions

Photographie — Rouleaux de pellicule formats 120 et 220 — Dimensions



Reference number
ISO 732:2000(E)

© ISO 2000

PDF disclaimer

This PDF file may contain embedded typefaces. In accordance with Adobe's licensing policy, this file may be printed or viewed but shall not be edited unless the typefaces which are embedded are licensed to and installed on the computer performing the editing. In downloading this file, parties accept therein the responsibility of not infringing Adobe's licensing policy. The ISO Central Secretariat accepts no liability in this area.

Adobe is a trademark of Adobe Systems Incorporated.

Details of the software products used to create this PDF file can be found in the General Info relative to the file; the PDF-creation parameters were optimized for printing. Every care has been taken to ensure that the file is suitable for use by ISO member bodies. In the unlikely event that a problem relating to it is found, please inform the Central Secretariat at the address given below.

© ISO 2000

All rights reserved. Unless otherwise specified, no part of this publication may be reproduced or utilized in any form or by any means, electronic or mechanical, including photocopying and microfilm, without permission in writing from either ISO at the address below or ISO's member body in the country of the requester.

ISO copyright office
Case postale 56 • CH-1211 Geneva 20
Tel. + 41 22 749 01 11
Fax + 41 22 749 09 47
E-mail copyright@iso.ch
Web www.iso.ch

Printed in Switzerland

Contents

Page

Foreword.....	iv
1 Scope	1
2 Normative references	1
3 Terms and definitions	1
4 Conditions for measurement of dimensions	2
5 Dimensions.....	2
6 Identification of exposed rolls.....	8
7 Package marking	8
Annex A (informative) General information.....	10
Bibliography	12

Foreword

ISO (the International Organization for Standardization) is a worldwide federation of national standards bodies (ISO member bodies). The work of preparing International Standards is normally carried out through ISO technical committees. Each member body interested in a subject for which a technical committee has been established has the right to be represented on that committee. International organizations, governmental and non-governmental, in liaison with ISO, also take part in the work. ISO collaborates closely with the International Electrotechnical Commission (IEC) on all matters of electrotechnical standardization.

International Standards are drafted in accordance with the rules given in the ISO/IEC Directives, Part 3.

Draft International Standards adopted by the technical committees are circulated to the member bodies for voting. Publication as an International Standard requires approval by at least 75 % of the member bodies casting a vote.

Attention is drawn to the possibility that some of the elements of this International Standard may be the subject of patent rights. ISO shall not be held responsible for identifying any or all such patent rights.

International Standard ISO 732 was prepared by Technical Committee ISO/TC 42, *Photography*.

This fourth edition cancels and replaces the third edition (ISO 732:1991 and ISO 1048:1991), of which it constitutes a combination and technical revision. A number of technical changes have been made to the figures that describe product dimensions, as well as to the specifications for paper width and thickness.

Annex A of this International Standard is for information only.

.....

Photography — 120-size and 220-size films — Dimensions

1 Scope

This International Standard provides specifications for

- dimensions of 120-size and 220-size films and of the spools common to both,
- dimensions of the backing paper for 120-size film and the leader and trailer paper for 220-size film, as well as the placement of the paster tape used for attaching these papers to the films,
- minimum length of film required in front of the leading edge of the first image and behind the trailing edge of the last image, and
- markings on the backing paper and the trailer-paper for identification of the intended photofinishing process.

2 Normative references

The following normative documents contain provisions which, through reference in this text, constitute provisions of this International Standard. For dated references, subsequent amendments to, or revisions of, any of these publications do not apply. However, parties to agreements based on this International Standard are encouraged to investigate the possibility of applying the most recent editions of the normative documents indicated below. For undated references, the latest edition of the normative document referred to applies. Members of ISO and IEC maintain registers of currently valid International Standards.

ISO 1:1975, *Standard reference temperature for industrial length measurements*.

ISO 554:1976, *Standard atmospheres for conditioning and/or testing — Specifications*.

3 Terms and definitions

For the purposes of this International Standard, the following terms and definitions apply.

3.1

backing paper

opaque, photographically inert paper, used with 120-size film and imprinted with frame numbers that are legible through a camera window, providing protection against the danger of light exposure of the film to which it is attached

NOTE The backing paper provides assistance at the beginning of the wind-up.

3.2

creep

difference in location of the film end relative to the numbers on the backing paper, when wound on the spool, compared to their respective positions when laid out flat

NOTE The difference exists because the backing paper, wound outside the film strip, assumes a curve of greater circumference than the film strip for each successive convolution.

3.3

exposure numbers

consecutive numbers, or sets of numbers, printed on the outside of the backing paper away from the film

NOTE The spacing of images on the film is established by sequential centring of these numbers in the window of older style cameras.

3.4

leader paper

trailer paper

shorter strips of paper attached to 220-size film (leader at the start of the film and trailer at the end of the film) for the purposes of light protection and winding, similar to the backing paper for 120-size film

3.5

spool

cylindrical device that has a flange at each end, an axial hole for a pin or spindle, and on which the roll of film and paper is wound

4 Conditions for measurement of dimensions

The dimensions and tolerances specified in this International Standard apply at the time of manufacture (except where specifically stated otherwise), measured under atmospheric conditions of $(23 \pm 2) ^\circ\text{C}$ and $(50 \pm 5) \%$ relative humidity, as specified in ISO 554.

All measuring instrument calibrations should be conducted at a temperature of $20 ^\circ\text{C}$ (as specified in ISO 1) and a relative humidity of 50 %.

5 Dimensions

5.1 120-size

The dimensions for 120-size film and backing paper shall conform to the values shown in Figure 1 and given in Table 1.

5.1.1 Thickness

The following thickness values shall be maintained:

- backing paper: 0,06 mm minimum and 0,12 mm maximum;
- backing paper plus film: $0,24 \text{ mm} \pm 0,04 \text{ mm}$;
- backing paper plus film and paster tape: $0,40 \text{ mm} \pm 0,10 \text{ mm}$.

5.1.2 Backing paper width

The maximum backing-paper width shall not exceed 62,90 mm.

The minimum backing-paper width is at the manufacturer's discretion, but should be sufficient to insure light-tightness of the undeveloped film.

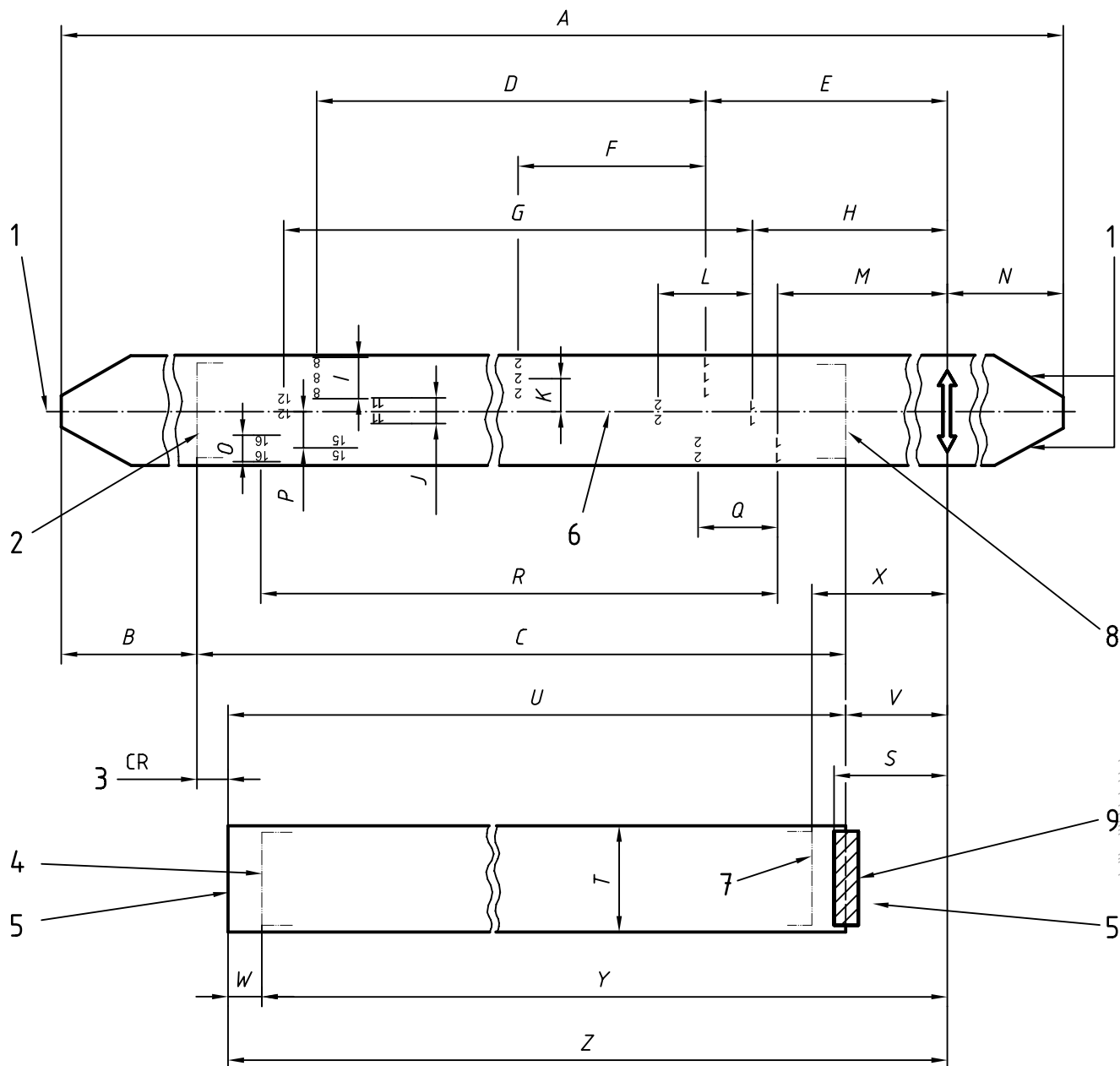

Key:

- | | |
|--|--|
| 1 Backing paper dimensions | 6 Centreline of backing paper |
| 2 Position of free end of film in the spooled roll | 7 Leading edge of first exposure |
| 3 Differential or creep | 8 Position of attached end of film |
| 4 Trailing edge of last exposure | 9 Paster for attaching film to backing paper |
| 5 Film dimensions | |

Figure 1 — 120-size film and backing paper

Table 1 — Dimensions of 120-size film and backing paper

Dimensions in millimetres

Symbol	Dimension		
	Minimum	Aim	Maximum
<i>A</i>	1 475		
<i>B</i>	230		
<i>C</i> ^a			
<i>D</i>	651		
<i>E</i>	298	300	302
<i>F</i>	93		
<i>G</i>	704		
<i>H</i>	246	248	250
<i>I</i>			17,5
<i>J</i> ^b			8
<i>K</i>	15,5	19,5	23,5
<i>L</i>	64		
<i>M</i>	238	240	242
<i>N</i>	237	257	277
<i>O</i>			13
<i>P</i>	14	18	22
<i>Q</i>	48		
<i>R</i>	720		
<i>S</i>			205
<i>T</i>	60,7		61,7
<i>U</i>	820		850
<i>V</i>	190		
<i>W</i>	15		
<i>X</i>	211		
<i>Y</i>			981
<i>Z</i>	996		

^a Dimension *C* was specified in the third edition of this International Standard, but has been judged no longer necessary.

^b The tolerance of the centreline of this number series versus the centreline of the backing paper is $\pm 3,2$ mm.

5.1.3 Paster tape

The shorter dimension of the paster tape (extending in the film's winding direction) shall not exceed 25 mm, and its overlap on the film shall not exceed 15 mm.

The longer dimension of the paster tape (across the width of the film and backing paper) shall extend at least to within 3 mm of both edges of the backing paper.

5.1.4 Exposure number orientation

The orientation of the exposure numbers on the backing paper is the option of the manufacturer.

5.1.5 Register marks for automatic cameras

A mark shall be imprinted at a specified distance ahead of the first image position on 120-size backing paper. This mark, shown by dimension *N* in Figure 1, shall have an arrow head at the top and at the bottom. The space between the arrow heads may be filled in at the discretion of the manufacturer (with, for example, a word or a symbol).

5.2 220-size

The dimensions for 220-size film and leader/trailer paper shall conform to the values shown in Figure 2 and given in Table 2.

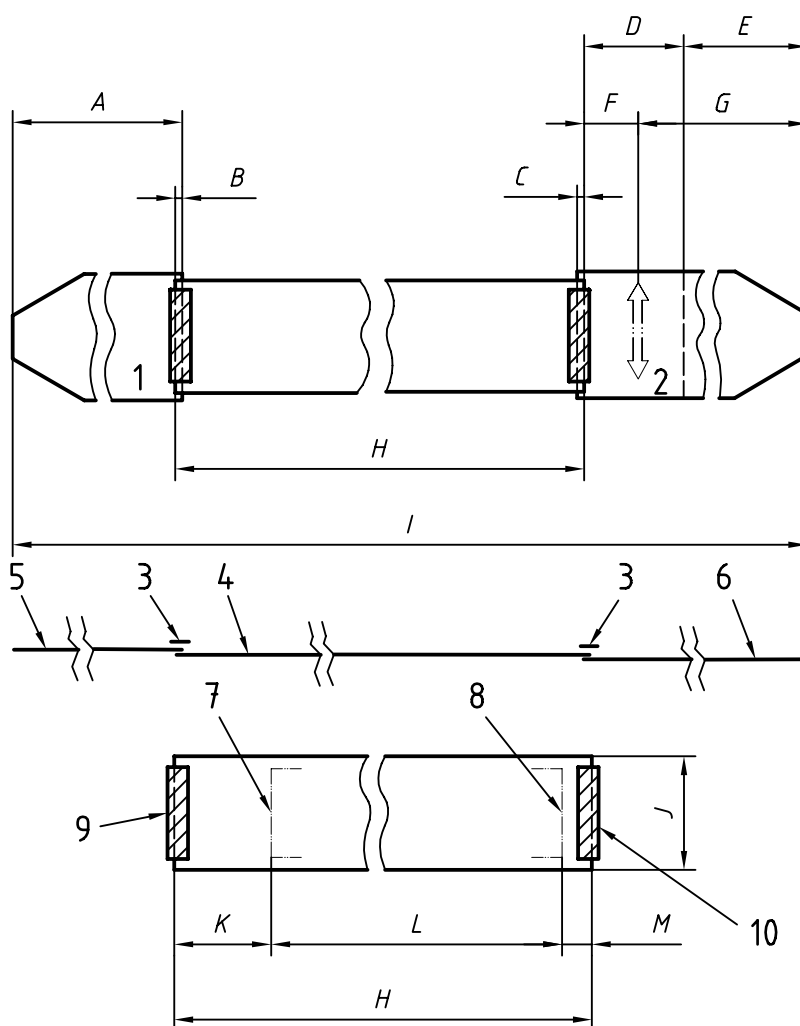

Key:

- | | |
|------------------------|---|
| 1 Trailer | 6 Paper leader |
| 2 Leader | 7 Trailing edge of last exposure |
| 3 Paster tape | 8 Leading edge of first exposure |
| 4 Film (emulsion side) | 9 Paster tape for attaching film to trailer |
| 5 Paper trailer | 10 Paster tape for attaching film to leader |

Figure 2 — 220-size film and leader/trailer paper

Table 2 — Dimensions of 220-size film and leader/trailer paper

Dimensions in millimetres

Symbol	Dimension		
	Minimum	Aim	Maximum
<i>A</i>	356		
<i>B</i>	0	3	6
<i>C</i>	1,5	4	8
<i>D</i>	315,5	321	326,5
<i>E</i>	236,5	256,5	276,5
<i>F</i>	179	184,5	190
<i>G</i>	373	393	413
<i>H</i>	1 651		1 700
<i>I</i>	2 544		
<i>J</i>	60,7		61,7
<i>K</i>	50		
<i>L</i>			1 580
<i>M</i>	21		

NOTE *D* and *E* refer to the alternative start mark.

5.2.1 Thickness

The following thickness values shall be maintained:

- leader/trailer paper: 0,06 mm minimum and 0,12 mm maximum;
- leader/trailer paper plus film and paster tape: 0,51 mm maximum.

5.2.2 Leader/trailer paper width

The maximum leader/trailer-paper width shall not exceed 62,90 mm.

The minimum leader/trailer paper width is at the manufacturer's discretion, but should be sufficient to insure light-tightness of the undeveloped film.

5.2.3 Paster tape

The shorter dimension of the paster tape (extending in the film's winding direction) shall not exceed 25 mm, and its overlap on the film shall not exceed 15 mm.

The longer dimension of the paster tape (across the width of the film and leader or trailer paper) shall extend at least to within 3 mm of both edges of the paper.

5.2.4 Register marks for automatic cameras

A mark shall be imprinted at a specified distance ahead of the first image position on the 220-size leader paper. This mark, shown by dimension *G* in Figure 2, shall have an arrow head at the top and at the bottom. The space between the arrow heads may be filled in at the discretion of the manufacturer (with, for example, a word or a

symbol), and indicates the starting position for automatic film-transport metering with most automatic cameras. A few automatic cameras require a different register mark (shown as a set of dashes, dimension E in Figure 2) closer to the start of the leader paper. This secondary marking is recognized, but the preferred position for the register mark is that indicated by dimension G .

5.3 Spool

The dimensions of the spool used for both 120-size and 220-size roll films shall conform to the values shown in Figure 3 and given in Table 3. See A.4 of annex A for more information about the spool.

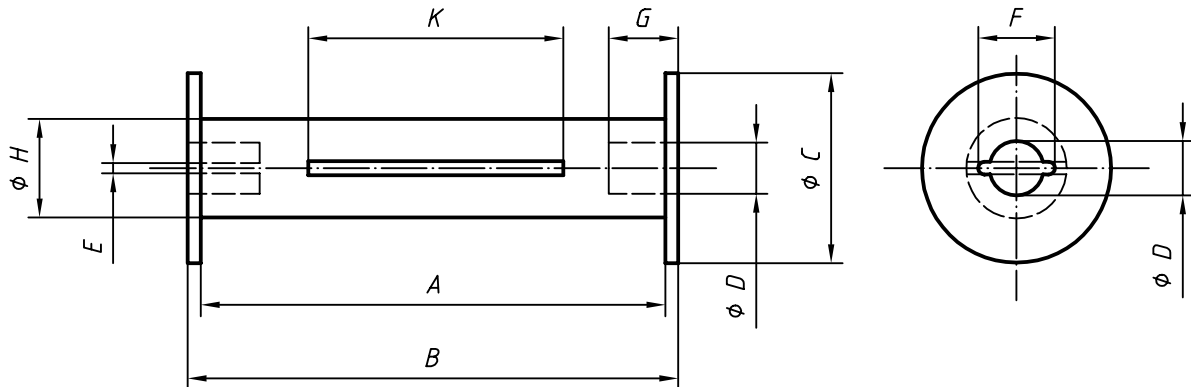

Figure 3 — Spool dimensions

Table 3 — Spool dimensions

Dimensions in millimetres

Symbol	Minimum dimension	Maximum dimension
A^a	62,50	
B	65,40	66,10
C	25,00	25,30
D	5,10	5,50
E^b	2,20	2,80
F^b	10,00	
G	9,00	
H	11,20	12,10
K	31,00	
M^c		0,30
N^d		0,40

^a This dimension includes all allowances for any distortion, such as tilted flanges.

^b A key slot is required in each flange of the spool for use as a take-up spool in the camera. The key slots may be cross shaped at the option of the manufacturer.

^c M is the concentricity tolerance of D and C or one-half of the total dial runout.

^d N is the concentricity tolerance of D and H or one-half of the total dial runout.

6 Identification of exposed rolls

6.1 General

A uniform and distinctive contrasting standard pattern shall appear along both edges of the trailing (exposed) end of the backing paper (120-size) or the trailer paper (220-size) of colour roll films in order to identify the intended photofinishing process. This shall be of sufficient length to cover at least the entire outer lap of the paper. Films for a black-and-white process shall not have these standard patterns along the trailing edges.

The pattern shall be additional to any other identifying printing included by the manufacturer. The manufacturer's own marking shall be so arranged as not to obscure the identifying patterns.

6.2 Colour negative process

The pattern for the colour negative process shall be a series of rectangles located along each slit edge. It is intended that there be sufficient rectangles to allow photofinishing personnel to distinguish them easily before film processing. A manufacturer may remove some of the rectangles in order to substitute additional information such as the type of processing chemistry intended.

Information regarding the appearance of these symbols is given in A.3 of annex A (see Figure A.1).

6.3 Colour reversal process

The pattern for the colour reversal film process shall be a series of "plus" (+) symbols located along each slit edge. It is intended that there be sufficient "plus" symbols to allow photofinishing personnel to distinguish them easily before film processing. A manufacturer may remove some of the "plus" symbols in order to substitute additional information such as the type of processing chemistry intended.

Information regarding the appearance of these symbols is given in A.3 of annex A (see Figure A.2).

6.4 Sealing bands

6.4.1 Colour roll films

The sealing bands for securing colour roll films after exposure shall be coloured. This can be either printed on a coloured background or by use of coloured printing on a white background.

6.4.2 Black-and-white roll films

In order to further differentiate black-and-white films from colour films, the sealing bands for securing black-and-white films after exposure should be a black-and-white-only background.

7 Package marking

Sufficient data shall be provided on a product's packaging to inform the user of proper use and handling.

Product packaging shall be marked so as to indicate

- product name and size,
- conditions of use (such as safelight), and
- conditions of shipping and storage.

To accomplish this, each of the packages which constitute the product's packaging should be marked so as to indicate one or more of the following;

- product name or trade name;
- name or trade mark of manufacturer;
- manufacturer's catalogue identification number;
- bar code information;
- quantity of units contained in the package;
- batch number and/or parent roll number;
- expiration date, "develop before" date, or inventory control code;
- manufacturer's recommended storage conditions;
- appropriate processing/recommended processing conditions;
- film speed.

Annex A (informative)

General information

A.1 Film-transport metering

With older style cameras, 120-size film has to be advanced manually into successive exposure positions by visually centring the exposure numbers (imprinted on the backing paper) within a window in the camera back. The following three number series are imprinted as a rule: 1-8; 1-12; 1-15.

Modern cameras for 120-size and 220-size films, on the other hand, provide automatic transport metering, and usually provide one of the combinations of nominal image sizes and numbers given in Table A.1, regardless of the numbers imprinted on the backing paper:

Table A.1 — Nominal image size and number of images

Nominal image size cm	Number of images	
	120-size	220-size
6 × 4,5	15 or 16 ^a	30 or 32 ^a
6 × 6	12	24
6 × 7	10	20
6 × 8	9	18
6 × 9	8	16
^a The exact number of images is a function of the camera design.		

A.2 Projected film length and creep

Dimensions for projected film length and creep apply to 120-size film only and are shown in Figure 1.

Projected film length is the distance, measured on the backing paper, between the two ends of the film when wound on a spool. The projected film length minus the actual (flat) film length equals the creep. Although this dimension was specified in the third edition of this International Standard, it has been judged no longer necessary, and has not been specified in this International Standard.

A.3 Photofinishing process symbols

The appearance of the photofinishing process symbols is shown in Figures A.1 and A.2.

It was previously suggested that dimension a should be at least 2,5 mm and 5 mm at most, with all dimensions a being approximately equal.

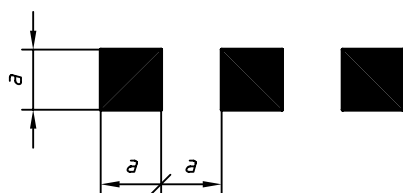
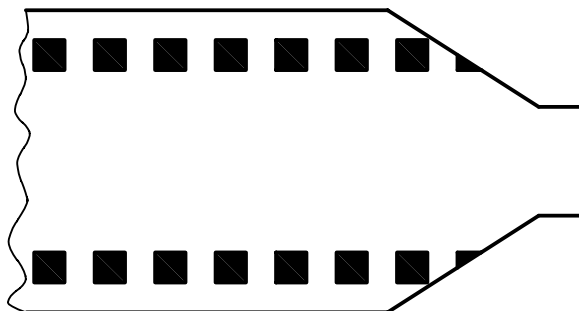

Figure A.1 — Colour negative pattern

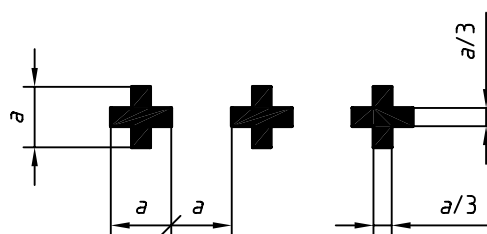
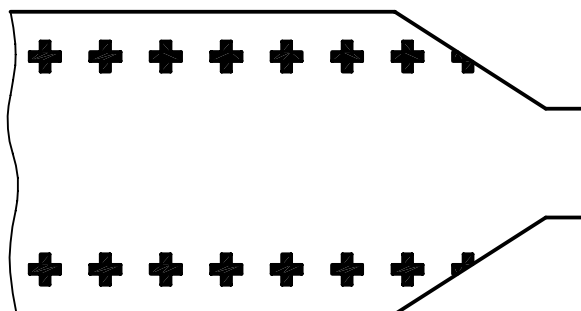

Figure A.2 — Colour reversal pattern

A.4 Spool design

Two interactive features of spools are the distance between flanges (dimension A in Figure 3) and the shape of the inside surface of the flange. Both affect the ability of the camera to wind the exposed roll tightly, thereby precluding light fog. Dimension A should be larger than the width of the paper in order to facilitate tight winding. On the other hand, the outer convolution of paper should form a slight interference fit with the spool flanges in order to prevent light penetrating down the edge of the roll.

Manufacturers optimize both conditions by tapering the inside of the spool flanges so that dimension A is smaller near the outer edge of the flanges.

The tapered flanges make it practical to specify only a minimum value for dimension A . Each manufacturer has designed the spool and paper to minimize light fog and winding problems. Consequently, optimum results may not be achieved when using film from one manufacturer and a take-up spool from a different manufacturer.

A.5 Start and finish margins

Additional film is needed at both ends (outside of the useable film length) so that clips or splicing tapes may be applied during photofinishing without damaging the images.

Bibliography

- [1] ISO 732:1991, *Photography — Film dimensions — 120 and 220 sizes.*
- [2] ISO 1048:1991, *Photography — Exposed roll films — Identification.*
- [3] ISO 1754:1998, *Photography — Cameras using 35 mm film and roll film — Picture sizes.*

