International Standard



719

INTERNATIONAL ORGANIZATION FOR STANDARDIZATION • МЕЖДУНАРОДНАЯ ОРГАНИЗАЦИЯ ПО СТАНДАРТИЗАЦИИ • ORGANISATION INTERNATIONALE DE NORMALISATION

ANSI Internat Doc Sect

Glass — Hydrolytic resistance of glass grains at 98 °C — Method of test and classification

Verre — Résistance hydrolytique du verre en grains à 98 °C — Méthode d'essai et classification

Second edition — 1985-10-01

UDC 666.1 : 620.193.4

Ref. No. ISO 719-1985 (E)

Descriptors : glass, tests, boiling temperature tests, determination, hydrolytic resistance, classification, designation.

ISO 719-1985 (E)

Price based on 5 pages

Foreword

ISO (the International Organization for Standardization) is a worldwide federation of national standards bodies (ISO member bodies). The work of preparing International Standards is normally carried out through ISO technical committees. Each member body interested in a subject for which a technical committee has been established has the right to be represented on that committee. International organizations, governmental and non-governmental, in liaison with ISO, also take part in the work.

Draft International Standards adopted by the technical committees are circulated to the member bodies for approval before their acceptance as International Standards by the ISO Council. They are approved in accordance with ISO procedures requiring at least 75 % approval by the member bodies voting.

International Standard ISO 719 was prepared by Technical Committee ISO/TC 48, *Laboratory glassware and related apparatus*.

ISO 719 was first published in 1981. This second edition cancels and replaces the first edition, of which it constitutes a technical revision.

Users should note that all International Standards undergo revision from time to time and that any reference made herein to any other International Standard implies its latest edition, unless otherwise stated.

© International Organization for Standardization, 1985 ●

Printed in Switzerland

Glass — Hydrolytic resistance of glass grains at 98 °C — Method of test and classification

1 Scope and field of application

This International Standard specifies

- a) a method for determining the hydrolytic resistance of glass grains at 98 °C. The resistance is measured and expressed by the volume of acid required for titration of the alkali extracted from the unit mass of glass, and may also be expressed by the amount of sodium oxide equivalent to this volume of acid;
- b) a classification of glass according to the hydrolytic resistance determined by the method of this International Standard.

This International Standard is intended for use on the less resistant types of glass. For the more resistant glasses, the method specified in ISO 720 is preferable.

NOTE — It is emphasized that there is no exact correlation between the classification laid down in this International Standard and that laid down in ISO 720, and it is therefore essential to identify which classification is being used.

2 References

ISO 385/1, *Laboratory glassware — Burettes — Part 1: General requirements.*

ISO 385/2, *Laboratory glassware — Burettes — Part 2: Burettes for which no waiting time is specified.*

ISO 565, *Test sieves — Woven metal wire cloth, perforated plate and electroformed sheet — Nominal sizes of openings.*

ISO 648, *Laboratory glassware — One-mark pipettes.*

ISO 720, *Glass — Hydrolytic resistance of glass grains at 121 °C — Method of test and classification.*

ISO 1042, *Laboratory glassware — One-mark volumetric flasks.*

ISO 1773, *Laboratory glassware — Boiling flasks (narrow-necked).*

ISO 3696, *Water for laboratory use — Specifications.*¹⁾

ISO 3819, *Laboratory glassware — Beakers.*¹⁾

1) At present at the stage of draft.

3 Principle

The method of test is a test for glass as a material applied on glass grains. Extraction of 2 g of grains, of particle size between 300 and 500 µm, with grade 2 water for 60 min at 98 °C. Measurement of the degree of the hydrolytic attack by analysis of the extraction solutions.

4 Reagents

During the test, unless otherwise stated, use only reagents of recognized analytical grade.

4.1 Grade 2 water, which complies with the requirements specified in ISO 3696 and which has been freed from dissolved gases, such as carbon dioxide, by boiling for at least 15 min in a boiling flask (5.6).

Such water can normally be stored for 24 h in a stoppered flask without change of the pH value.

When tested immediately before use the water shall be neutral to methyl red, i.e. it shall produce an orange-red (not a violet-red or yellow) colour corresponding to $\text{pH } 5,5 \pm 0,1$ when two drops of the methyl red indicator solution (4.4) are added to 25 ml of the water.

NOTE — The water, so coloured, may also be used as a reference solution (see clause 7).

4.2 Hydrochloric acid, standard volumetric solution, $c(\text{HCl}) = 0,01 \text{ mol/l}$.

4.3 Hydrochloric acid, solution, $c(\text{HCl}) \approx 1 \text{ mol/l}$.

4.4 Methyl red, indicator solution.

Dissolve 25 mg of the sodium salt of methyl red ($\text{C}_{15}\text{H}_{14}\text{N}_3\text{NaO}_2$) in 100 ml of the grade 2 water (4.1).

4.5 Acetone (CH_3COCH_3).

ISO 719-1985 (E)

4.6 Distilled water or water of equivalent purity (grade 3 water complying with the requirements specified in ISO 3696).

5 Apparatus

Ordinary laboratory apparatus, and

5.1 Balance, accurate to ± 5 mg or better.

5.2 Burettes, having a capacity of 5 ml, 2 ml or 1 ml, complying with the requirements specified for class A burettes in ISO 385/2 (see also general requirements specified in ISO 385/1) and made of glass of hydrolytic resistance grain class HGA 1 as specified in ISO 720¹⁾.

The capacity of the burettes shall be chosen according to the expected consumption of hydrochloric acid (4.2).

5.3 Pipette, having a capacity of 25 ml and complying with the requirements specified for class A pipettes in ISO 648.

5.4 One-mark volumetric flasks, having a capacity of 50 ml, complying with the requirements specified for class A one-mark volumetric flasks in ISO 1042, made of glass of hydrolytic resistance grain class HGA 1 as specified in ISO 720¹⁾, and with glass stoppers.

NOTE — It is advisable to select flasks with the graduation mark in the lower half of the neck.

Before use, each new flask shall be pretreated in the following manner: The flasks shall be filled to above the graduation mark with hydrochloric acid (4.3) and heated at just above the test temperature for 2 h in the heating bath (5.19). The flasks shall then be rinsed with water (4.6), filled to above the graduation mark with water and heated as above for two periods of 1 h, using fresh water each time.

NOTES

1 Flasks made from vitreous silica may also be used, in which case pretreatment is not required.

2 When flasks have been used to measure the alkali-release from grain of low-resistance glass, it is advisable to pretreat them again, as above, before using them for further tests in order to eliminate cross-contamination.

5.5 Conical flasks, having a capacity of 100 ml and complying with the requirements of ISO 1773.

5.6 Boiling flasks, having a capacity of 1 000 ml, complying with the requirements of ISO 1773 and made of vitreous silica or borosilicate glass.

Before use, each new flask shall be pretreated as described in 5.4.

5.7 Beakers, having a capacity of 100 ml and complying with the requirements of ISO 3819.

5.8 Weighing bottles, having a capacity of about 20 ml.

5.9 Desiccator.

5.10 Hammer, having a mass of about 0,5 kg.

5.11 Mortar and pestle, made of hardened magnetic steel, and of the design and approximate dimensions shown in the figure.

5.12 Magnet.

5.13 Sieves, complying with the requirements of ISO 565 and comprising a set of 200 mm diameter square-aperture sieves, with stainless steel mesh, including:

- a sieve A of 500 μm aperture;
- a sieve B of 300 μm aperture;
- a sieve O of a convenient aperture between 600 and 1 000 μm .

The cover, pan and, especially, the rings shall be of stainless steel or lacquered wood.

NOTE — The use of sieve O is recommended to retain larger pieces of glass and to avoid heavy wear on sieve A.

5.14 Ball-mill

The mill shall be made of agate or stainless steel with a volume of 250 ml. Two balls with a diameter of 40 mm or three balls with a diameter of 30 mm are suitable.

5.15 Sieving-machine

A mechanical sieve-shaker or sieving-machine may be used to sieve the grains.

5.16 Ultrasonic cleaner (laboratory type).

5.17 Drying oven, suitable for operation up to 150 °C.

5.18 Thermometer, covering the range from 90 to 110 °C, capable of being read to an accuracy of $\pm 0,2$ °C.

5.19 Heating bath, gas or electrically heated, thermostatically controlled, having capacity sufficient to contain at least 1 litre of liquid for each flask used in the test and capable of carrying out the heating cycle specified in clause 7.

1) Glass of hydrolytic resistance grain class ISO 719-HGB 1 adequately meets the requirements of class HGA 1 specified in ISO 720.

Approximate dimensions
in millimetres

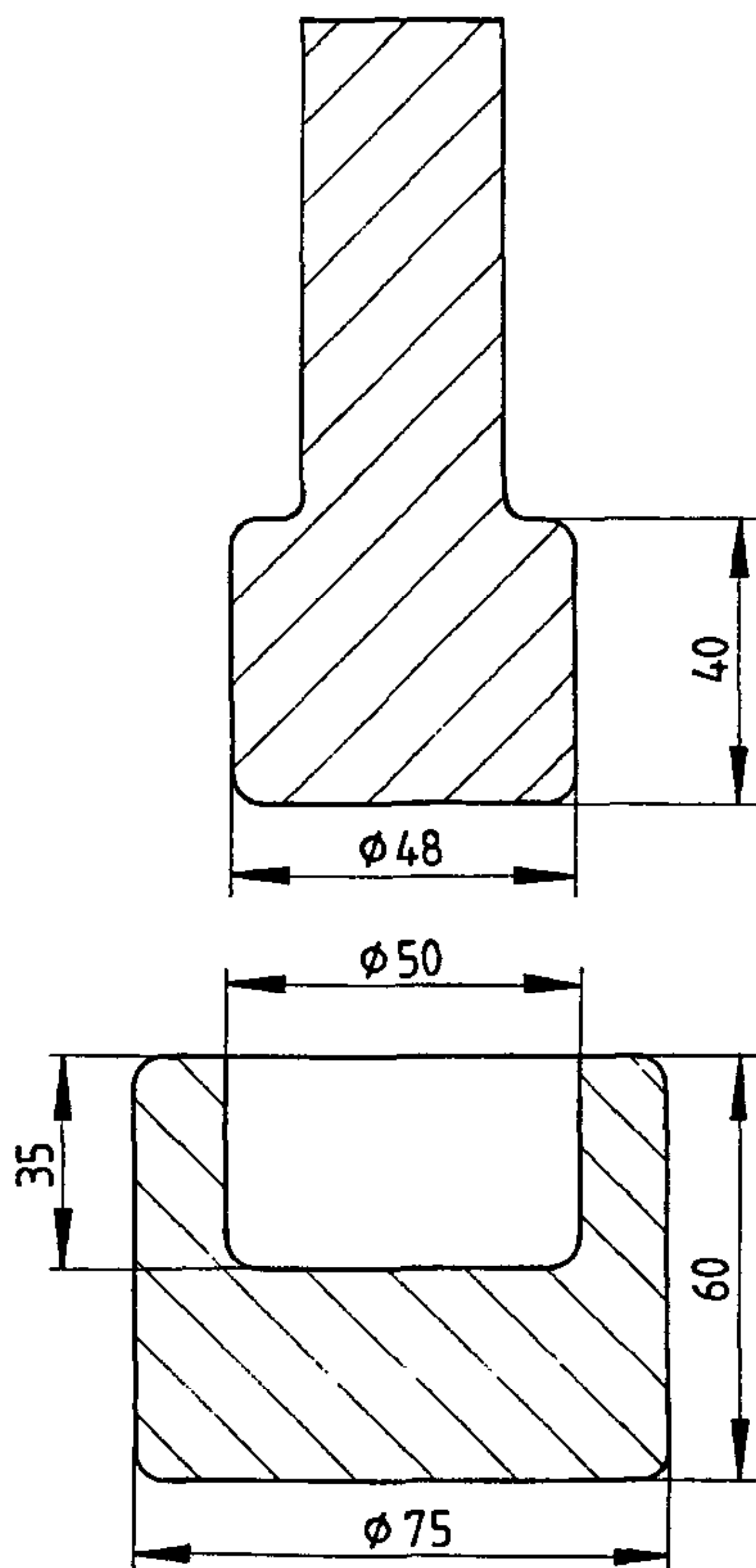

Figure — Mortar and pestle

6 Preparation of sample

6.1 Density of the glass

The density of the glass to be tested should, preferably, be $2,4 \pm 0,2 \text{ g/cm}^3$ at $20 \text{ }^\circ\text{C}$.

6.2 Crushing

Check that the articles as received have been annealed to a commercially acceptable quality.

NOTE — If an article is not annealed to a commercially acceptable quality, this fact should be noted because the results can be affected. Such articles, if very badly annealed, may also break very easily and extra care should be taken when handling them. Further annealing should not be carried out before the test.

Wrap the glass articles, which should, preferably, have a wall thickness greater than 1,5 mm, in clean paper and crush to pieces not more than 30 mm across.

6.3 Manual preparation

Place 30 to 40 g of pieces (see 6.2) between 10 and 30 mm across in the mortar (5.11), insert the pestle (5.11), and strike it sharply, once only, with the hammer (5.10).

NOTE — If more than one hammer blow is used in crushing the glass, the very fine particles produced may be compacted into aggregates which may or may not be subsequently broken down and which can therefore introduce further variables into the test.

Transfer the glass from the mortar to the upper sieve O of the assembled set of sieves (5.13), and shake the set of sieves briefly to separate the finer particles. Return the glass remaining on sieves A and O to the mortar. Repeat crushing and sieving until only about 10 g of glass remain on sieve O. Discard the glass from sieve O and from the receiving pan. Shake the set of sieves by hand for 5 min. Reserve for the test those grains which pass through sieve A, but which are retained on sieve B.

At least 10 g of sample are required for the test. If it is necessary to crush and sieve more sample, it is essential that the sample already obtained should be removed from sieve B and stored in a weighing bottle (5.8).

After completion of all crushing and sieving, combine the samples, spread the grains on clean glazed paper and remove any iron particles using the magnet (5.12). Transfer the grains into a beaker (5.7) for cleaning.

6.4 Mechanical preparation

Transfer about 50 g of the coarsely broken glass (see 6.2) into the mill-beaker (5.14), add the balls and crush thin-walled glass (wall thickness $< 1,5 \text{ mm}$) for 2 min, thick-walled glass ($> 1,5 \text{ mm}$) for 5 min.

Transfer the grains to the upper sieve O of the assembled set (5.13) of the sieving-machine (5.15), sieve for about 30 s and collect the grains retained on sieve B in the beaker (5.7), which shall be kept in the desiccator (5.9). Transfer the glass from sieves O and A back into the ball-mill and crush again for the time given above. Repeat sieving and crushing until about 10 g of grains have been collected from sieve B. Continue as specified in 6.3, last paragraph.

6.5 Cleaning

Add to the grains in each beaker (5.7) 30 ml of the acetone (4.5) and scour the grains by a suitable means, such as a rubber- or plastics-coated glass rod.

NOTE — The method of scouring involves holding the beaker at an angle of about 30° to 45° firmly against the bench and pressing firmly the covered end of a glass rod of about 10 mm in diameter into the bottom corner and against the sides, so that the grains are trapped between it and the sides and the bottom of the beaker as the rod is rotated around the beaker. Continue the rotation for about 20 revolutions.

After scouring, swirl the grains and decant as much acetone as possible. Add another 30 ml of the acetone, swirl and decant again and add a new portion of the acetone. Fill the bath of the ultrasonic cleaner (5.16) with water at room temperature, then place the beaker in the rack and immerse it until the level of the acetone is at the level of the water; apply the ultrasonics for 1 min.

Swirl the beaker and decant the acetone as completely as possible and then repeat the ultrasonic cleaning operation. If a fine turbidity persists, repeat the ultrasonic cleaning and acetone washing until the solution remains clear. Swirl and decant the acetone, then dry the grains, first by putting the beaker with the grains on a warm plate to remove excess acetone and then by heating at 140 °C for 20 min in the drying oven (5.17).

Transfer the dried grains from the oven into a weighing bottle (5.8), insert the stopper and cool in the desiccator (5.9).

7 Procedure

Weigh 2,00 g of the cleaned and dried grains into each of three of the one-mark volumetric flasks (5.4). Fill the flasks to the mark with the grade 2 water (4.1) and fill two more flasks with the water, one to serve as a reference solution and the other to serve as a temperature control.

Distribute the glass grains evenly over the flat bases of the sample flasks by gently shaking them, then place all of the flasks, without stoppers, in the heating bath (5.19), so that they are immersed to half-way up the necks (a rack to hold the flasks may be used). Increase the rate of heating such that the specified temperature of $98 \pm 0,5$ °C is achieved in the control flask within 3 min; after a further 2 min, insert the stoppers. Continue heating for 60 ± 1 min from the time of immersion, maintaining the temperature at $98 \pm 0,5$ °C in the flasks.

Remove the flasks from the heating bath, take out the stoppers, cool the flasks in running water and adjust the contents of each flask to the mark with the grade 2 water. Replace the stoppers and mix the contents of each flask thoroughly, then allow to stand until the grains settle and a clear supernatant solution is obtained. Complete the titration within 1 h.

By means of the pipette (5.3), transfer 25 ml of the clear solution from each flask into separate conical flasks (5.5), add to each of these flasks two drops of the methyl red indicator solution (4.4), and titrate immediately with the hydrochloric acid solution (4.2), until the colour matches exactly that of the 25 ml of the water of the reference solution plus two drops of the indicator contained in a similar conical flask.

8 Expression of results

8.1 Calculation

Calculate the mean value of the results, in millilitres of hydrochloric acid solution (4.2) per gram of sample, and, if required, its equivalent in alkali extracted, calculated as micrograms of sodium oxide (Na₂O) per gram of glass grains:

$$1 \text{ ml of hydrochloric acid solution} \\ [c(\text{HCl}) = 0,01 \text{ mol/l}] \cong 310 \text{ } \mu\text{g of sodium oxide}$$

If the highest and the lowest observed values differ by more than the permissible range given in table 1, repeat the test.

8.2 Classification

Glass shall be classified as shown in table 2, according to the consumption of acid and its equivalent of alkali [expressed as sodium oxide (Na₂O)], when tested by the method specified in this International Standard.

8.3 Designation

For convenience of reference to the hydrolytic resistance of glass as a material complying with the classification of this International Standard, the use of a designation as follows is recommended:

Example:

The designation for a glass with a consumption of 0,60 ml of hydrochloric acid solution [$c(\text{HCl}) = 0,01 \text{ mol/l}$] per gram of glass grains equivalent to 186 μg of sodium oxide per gram of glass grains (class HGB 3) shall be:

Glass, hydrolytic resistance grain class ISO 719 - HGB 3

9 Test report

The test report shall include the following information:

- a) a reference to this International Standard;
- b) an identification of the sample;
- c) the consumption of hydrochloric acid solution [$c(\text{HCl}) = 0,01 \text{ mol/l}$], in millilitres per gram of glass grains, mean value;
- d) in addition, if required, the equivalent of alkali, in micrograms of sodium oxide per gram of glass grains, mean value;
- e) the hydrolytic resistance grain class HGB (designation of the glass tested);
- f) the wall thickness of the articles used for the test if it was $< 1,5 \text{ mm}$;
- g) the density of the glass if it was outside the range of $2,4 \pm 0,2 \text{ g/cm}^3$ at 20 °C;
- h) a statement, if appropriate, that the glass article used for the test was *not annealed* to commercially acceptable quality.

Table 1 — Permissible range of the values obtained

Mean of the values obtained for the consumption of hydrochloric acid solution [c(HCl) = 0,01 mol/l] (4.2) per gram of glass grains ml/g	Permissible range of the values obtained
up to and including 0,10 from 0,10 up to and including 0,20 from 0,20 upwards	30 % of the mean 20 % of the mean 10 % of the mean

Table 2 — Limit values in the hydrolytic resistance grains test (boiling water test)

Class ¹⁾	Consumption of hydrochloric acid solution [c(HCl) = 0,01 mol/l] (4.2) per gram of glass grains ml/g	Equivalent of alkali expressed as mass of sodium oxide (Na ₂ O) per gram of glass grains µg/g
HGB 1	up to and including 0,10	up to and including 31
HGB 2	from 0,10 up to and including 0,20	from 31 up to and including 62
HGB 3	from 0,20 up to and including 0,85	from 62 up to and including 264
HGB 4	from 0,85 up to and including 2,0	from 264 up to and including 620
HGB 5	from 2,0 up to and including 3,5	from 620 up to and including 1 085

1) "HGB" stands for the hydrolytic resistance of glass grains according to the boiling water test method.