**Machine tools — Connecting dimensions
of spindle noses and work holding
chucks —**

Part 3:
Bayonet type

*Machines-outils — Dimensions d'assemblage des nez de broches et
des mandrins porte-pièces —*

Partie 3: Type baïonnette



Reference number
ISO 702-3:2007(E)

© ISO 2007

PDF disclaimer

This PDF file may contain embedded typefaces. In accordance with Adobe's licensing policy, this file may be printed or viewed but shall not be edited unless the typefaces which are embedded are licensed to and installed on the computer performing the editing. In downloading this file, parties accept therein the responsibility of not infringing Adobe's licensing policy. The ISO Central Secretariat accepts no liability in this area.

Adobe is a trademark of Adobe Systems Incorporated.

Details of the software products used to create this PDF file can be found in the General Info relative to the file; the PDF-creation parameters were optimized for printing. Every care has been taken to ensure that the file is suitable for use by ISO member bodies. In the unlikely event that a problem relating to it is found, please inform the Central Secretariat at the address given below.



COPYRIGHT PROTECTED DOCUMENT

© ISO 2007

All rights reserved. Unless otherwise specified, no part of this publication may be reproduced or utilized in any form or by any means, electronic or mechanical, including photocopying and microfilm, without permission in writing from either ISO at the address below or ISO's member body in the country of the requester.

ISO copyright office
Case postale 56 • CH-1211 Geneva 20
Tel. + 41 22 749 01 11
Fax + 41 22 749 09 47
E-mail copyright@iso.org
Web www.iso.org

Published in Switzerland

Contents

Page

Foreword.....	iv
1 Scope	1
2 Interchangeability	1
3 Sizes for interchangeability	2
3.1 Spindle noses	2
3.2 Bayonet disc	4
3.3 Face plates	6
3.4 Studs with nuts and collars	8
Bibliography	10

Foreword

ISO (the International Organization for Standardization) is a worldwide federation of national standards bodies (ISO member bodies). The work of preparing International Standards is normally carried out through ISO technical committees. Each member body interested in a subject for which a technical committee has been established has the right to be represented on that committee. International organizations, governmental and non-governmental, in liaison with ISO, also take part in the work. ISO collaborates closely with the International Electrotechnical Commission (IEC) on all matters of electrotechnical standardization.

International Standards are drafted in accordance with the rules given in the ISO/IEC Directives, Part 2.

The main task of technical committees is to prepare International Standards. Draft International Standards adopted by the technical committees are circulated to the member bodies for voting. Publication as an International Standard requires approval by at least 75 % of the member bodies casting a vote.

Attention is drawn to the possibility that some of the elements of this document may be the subject of patent rights. ISO shall not be held responsible for identifying any or all such patent rights.

ISO 702-3 was prepared by Technical Committee ISO/TC 39, *Machine tools*, Subcommittee SC 8, *Work holding spindles and chucks*.

This second cancels and replaces the first edition (ISO 702-3:1975), of which all the clauses, tables and figures have been technically revised.

ISO 702 consists of the following parts, under the general title *Machine tools — Connecting dimensions of spindle noses and work holding chucks*:

- *Part 1: Conical connection*
- *Part 2: Camlock type*
- *Part 3: Bayonet type*
- *Part 4: Cylindrical connection*

Machine tools — Connecting dimensions of spindle noses and work holding chucks —

Part 3: Bayonet type

1 Scope

This part of ISO 702 specifies the sizes for interchangeability of bayonet-type lathe spindle noses and corresponding face plates.

NOTE The “conical connection”, “camlock type” and “cylindrical connection” are dealt with in ISO 702-1, ISO 702-2 and ISO 702-4, respectively.

2 Interchangeability

In this part of ISO 702, all the dimensions and tolerances are expressed in millimetres.

3 Sizes for interchangeability

3.1 Spindle noses

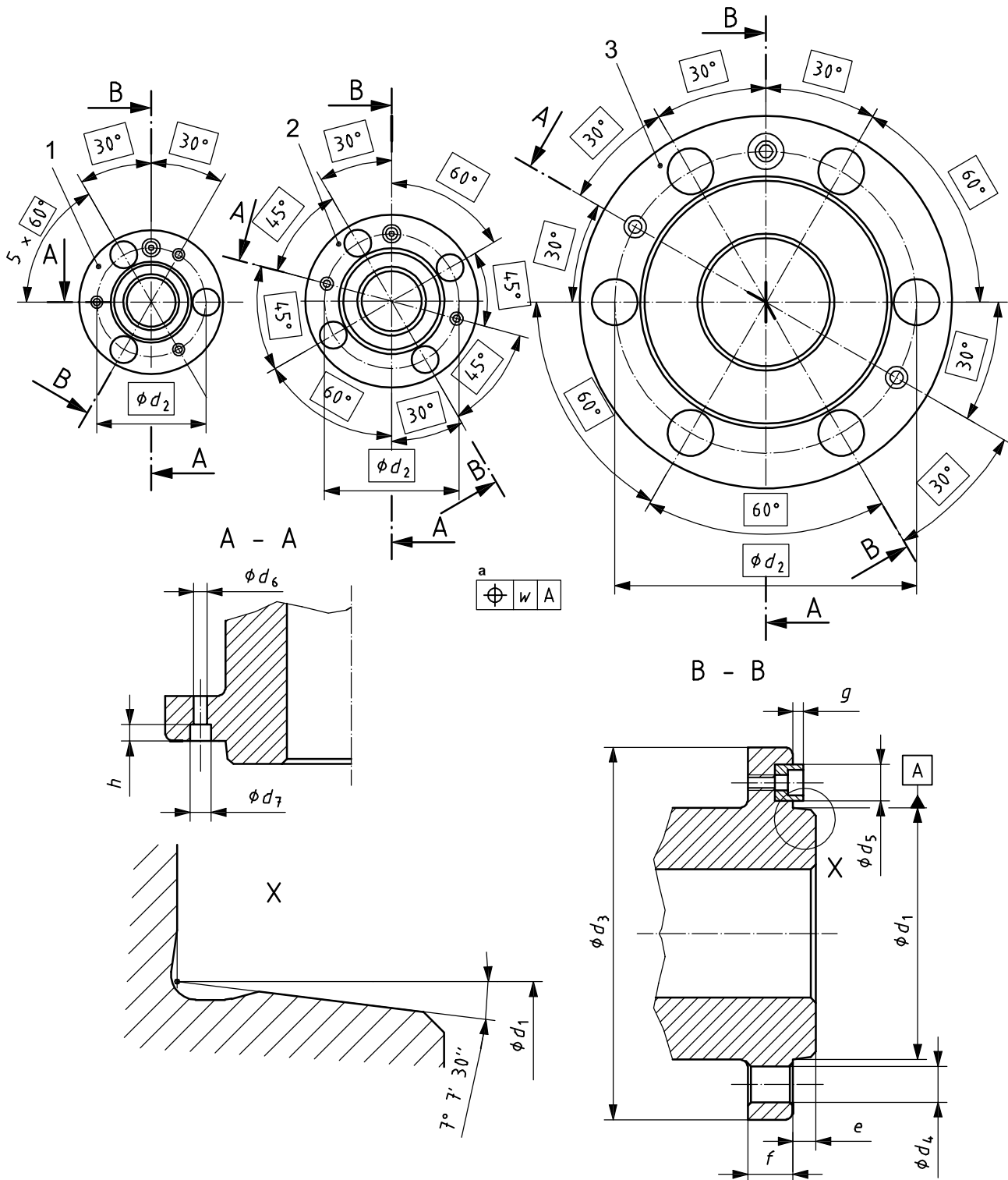

- Key**
- 1 size Nos. 3 and 4, No. 3 without button
 - 2 size Nos. 5 to 8
 - 3 size Nos. 11 to 20
 - a All holes.

Figure 1 — Spindle noses

Table 1 — Dimensions of spindle noses

Dimension	Size No.								
	3	4	5	6	8	11	15	20	
d_1	nom.	53,975	63,513	82,563	106,375	139,719	196,869	285,775	412,775
	tol.	+0,008 0	+0,008 0	+0,010 0	+0,010 0	+0,012 0	+0,014 0	+0,016 0	+0,020 0
d_2	75	85	104,8	133,4	171,4	235	330,2	463,6	
d_3	102	112	135	170	220	290	400	540	
d_4	21	21	21	23	29	36	43	43	
d_5 H8/h8	21	14,25	15,9	19,05	23,8	28,6	34,9	41,3	
d_6	6,4	6,4	6,4	8,4	10,5	10,5	13	13	
d_7	10,4	10,4	10,4	13,5	16,5	16,5	19	19	
e	11	11	13	14	16	18	19	21	
f	16	20	22	25	28	35	42	48	
g	16	5	5	5	6	8	8	8	
h	10	10	10	11	12	13	15	15	
w	0,2	0,2	0,2	0,2	0,2	0,2	0,3	0,3	
NOTE	General tolerance for untoleranced dimensions: $\pm 0,4$ mm.								

3.2 Bayonet disc

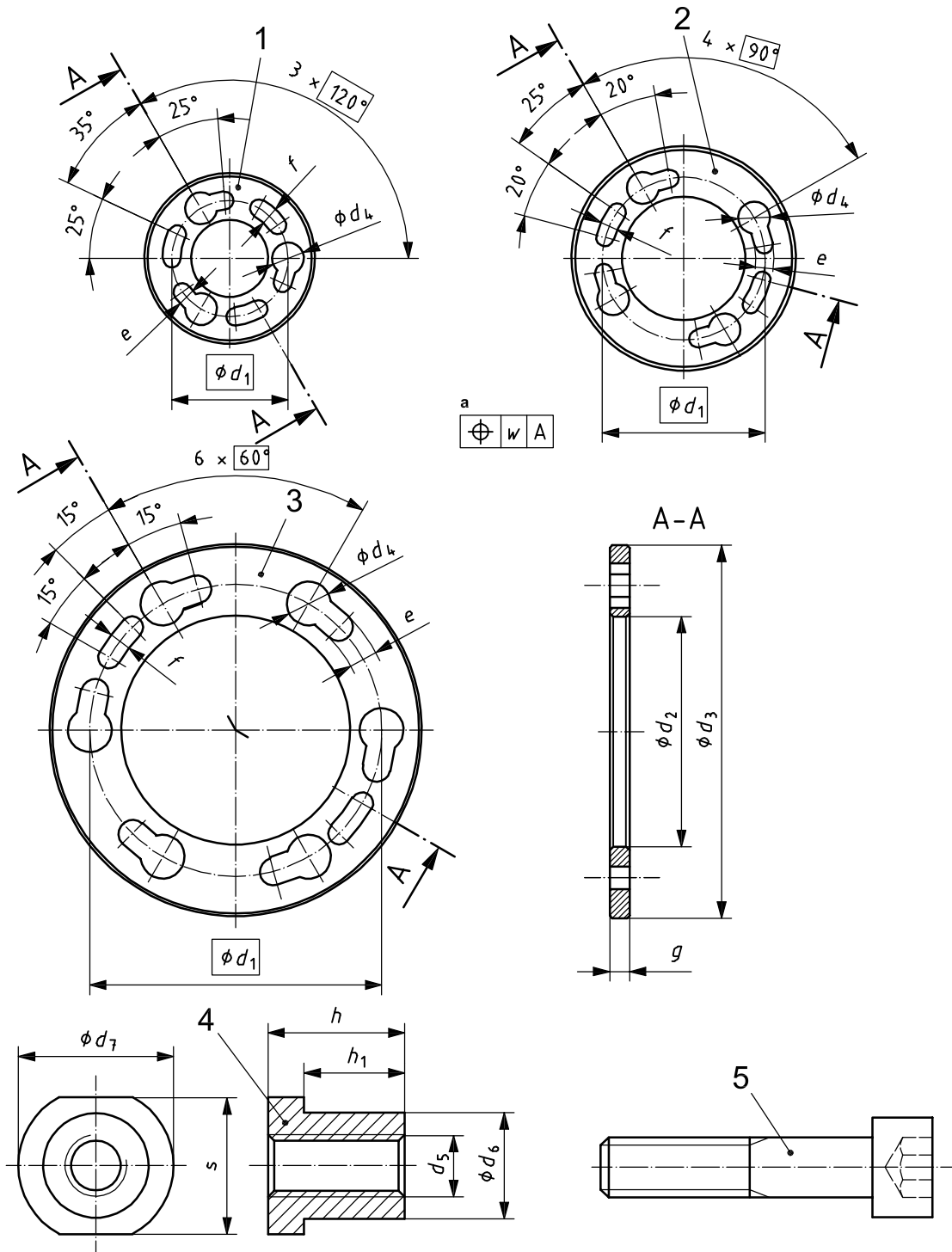

- Key**
- 1 size Nos. 3 and 4
 - 2 size Nos. 5 to 8
 - 3 size Nos. 11 to 20
 - 4 thrust socket
 - 5 hexagon-socket head screw
 - a All holes.

Figure 2 — Bayonet disc

Table 2 — Dimensions of bayonet disc

Dimension	Size No.								
	3	4	5	6	8	11	15	20	
d_1	75	85	104,8	133,4	171,4	235	330,2	463,6	
d_2	50	60	80	100	130	185	270	400	
d_3	110	120	145	180	230	300	410	550	
d_4	21	21	21	23	29	36	43	43	
d_5	M6	M6	M6	M8	M10	M10	M12	M12	
d_6	11	11	11	13	17	17	22	22	
d_7	16	16	16	19	25	25	32	32	
e	11,5	11,5	11,5	14	18	23	27	27	
f	11,5	11,5	11,5	14	18	18	23	23	
g	$\begin{matrix} 0 \\ -0,1 \end{matrix}$	5	6	8	10	12	16	18	22
h		8	9	12	15	18	22	26	30
h_1	$\begin{matrix} +0,2 \\ 0 \end{matrix}$	5,2	6,2	8,2	10,2	12,2	16,2	18,3	22,3
s	$\begin{matrix} 0 \\ -0,2 \end{matrix}$	14	14	14	17	22	22	27	27
w		0,2	0,2	0,2	0,2	0,2	0,2	0,3	0,3
Hexagon-socket head screw	M6 × 15	M6 × 20	M6 × 25	M8 × 30	M10 × 35	M10 × 45	M12 × 55	M12 × 65	
NOTE	General tolerance for untoleranced dimensions: ± 0,4 mm.								

3.3 Face plates

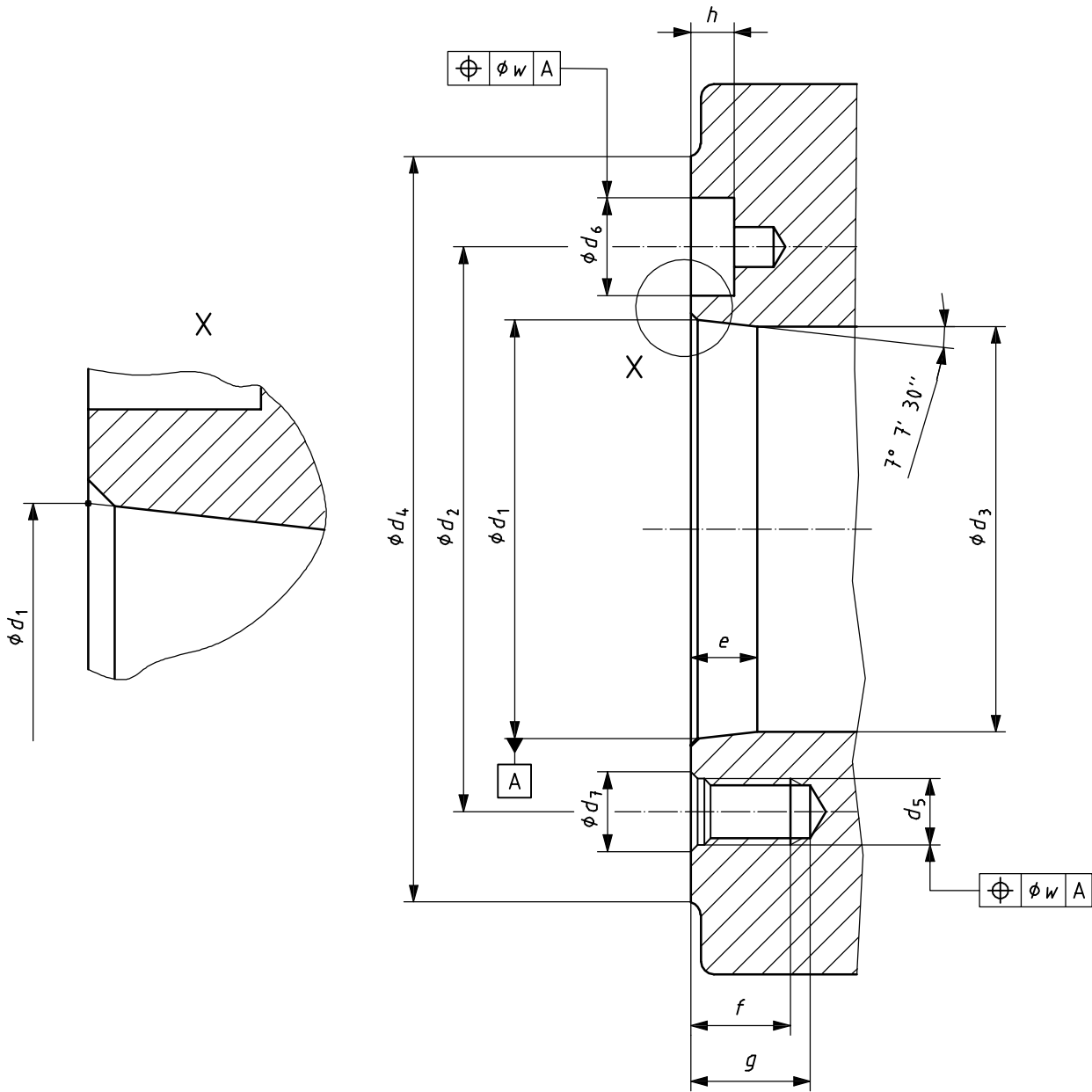
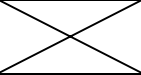

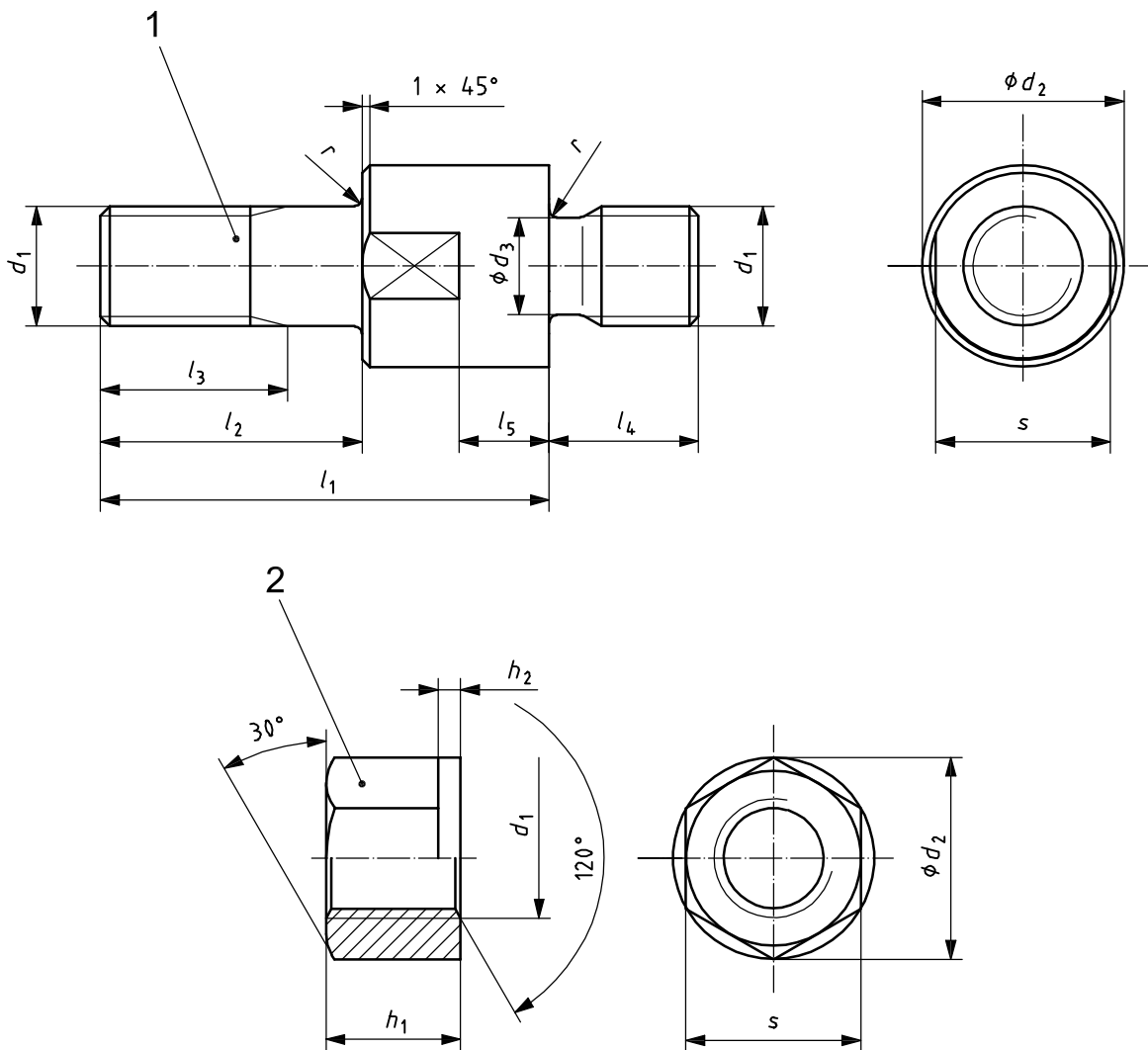

Figure 3 — Face plates

Table 3 — Dimensions of face plates

Dimension	Size No.							
	3	4	5	6	8	11	15	20
d_1 nom.	53,975	63,513	82,563	106,375	139,719	196,869	285,775	412,775
tol. Type 1 ^a	+0,003 -0,005	+0,003 -0,005	+0,004 -0,006	+0,004 -0,006	+0,004 -0,008	+0,004 -0,010	+0,004 -0,012	+0,005 -0,015
tol. Type 2 ^a	+0,008 0	+0,008 0	+0,010 0	+0,010 0	+0,012 0	+0,014 0	+0,016 0	+0,020 0
d_2	75	85	104,8	133,4	171,4	235	330,2	463,6
d_3	51,5	61	79,6	103,2	136,2	192,9	281,5	408
d_4	102	112	135	170	220	290	400	540
d_5	M10	M10	M10	M12	M16	M20	M24	M24
d_6 $\begin{matrix} +0,1 \\ 0 \end{matrix}$		14,7	16,3	19,45	24,25	29,4	35,7	42,1
d_7	11	11	11	14	18	22	26	26
e	10	10	12	13	14	16	17	19
f	15	15	15	18	24	30	36	36
g	18	18	18	22	28	34	40	40
h		6,5	6,5	6,5	8	10	10	10
w	0,2	0,2	0,2	0,2	0,2	0,2	0,3	0,3
Stud	M10 × 34	M10 × 39	M10 × 43	M12 × 50	M16 × 60	M20 × 75	M24 × 90	M24 × 100
NOTE General tolerance for untoleranced dimensions: $\pm 0,4$ mm.								
^a Type identification shall be marked.								

3.4 Studs with nuts and collars



Key

- 1 stud
- 2 nut with collars

Figure 4 — Stud bolt with collar nut

Table 4 — Dimensions of studs with nuts and collars

Dimension	Size No.							
	3	4	5	6	8	11	15	20
d_1	M10	M10	M10	M12	M16	M20	M24	M24
d_2 h11	19,5	19,5	19,5	21,5	27	34	41	41
d_3	7,7	7,7	7,7	9,4	13	16,4	19,6	19,6
h_1	12	12	12	14	18	22	27	27
h_2	3	3	3	3	3	4	4	4
l_1	34	39	43	50	60	75	90	100
l_2	20	22	24	28	35	44	52	56
l_3	18	18	18	20	25	30	36	36
l_4	12	12	12	15	20	25	30	30
l_5	5	8	10	12	12	15	20	26
r	0,6	0,6	0,6	1	1	1	1,6	1,6
s	17	17	17	19	24	30	36	36
NOTE	General tolerance for untoleranced dimensions: $\pm 0,4$ mm.							

Bibliography

- [1] ISO 702-1, *Machine tools — Connecting dimensions of spindle noses and work holding chucks — Part 1: Conical connection*
- [2] ISO 702-2, *Machine tools — Connecting dimensions of spindle noses and work holding chucks — Part 2: Camlock type*
- [3] ISO 702-4, *Machine tools — Connecting dimensions of spindle noses and work holding chucks — Part 4: Cylindrical connection*

ICS 25.060.20

Price based on 10 pages