

# INTERNATIONAL STANDARD

**ISO  
695**

Third edition  
1991-05-15

**ANSI Internat Doc Sect**

---

---

## **Glass — Resistance to attack by a boiling aqueous solution of mixed alkali — Method of test and classification**

*Verre — Résistance à l'attaque par une solution aqueuse bouillante d'un  
mélange alcalin — Méthode d'essai et classification*



Reference number  
ISO 695:1991(E)

## **Foreword**

ISO (the International Organization for Standardization) is a worldwide federation of national standards bodies (ISO member bodies). The work of preparing International Standards is normally carried out through ISO technical committees. Each member body interested in a subject for which a technical committee has been established has the right to be represented on that committee. International organizations, governmental and non-governmental, in liaison with ISO, also take part in the work. ISO collaborates closely with the International Electrotechnical Commission (IEC) on all matters of electrotechnical standardization.

Draft International Standards adopted by the technical committees are circulated to the member bodies for voting. Publication as an International Standard requires approval by at least 75 % of the member bodies casting a vote.

International Standard ISO 695 was prepared by Technical Committee ISO/TC 48, *Laboratory glassware and related apparatus*.

This third edition cancels and replaces the second edition (ISO 695:1984), of which it constitutes a technical revision.

© ISO 1991

All rights reserved. No part of this publication may be reproduced or utilized in any form or by any means, electronic or mechanical, including photocopying and microfilm, without permission in writing from the publisher.

International Organization for Standardization  
Case Postale 56 • CH-1211 Genève 20 • Switzerland

Printed in Switzerland

# Glass — Resistance to attack by a boiling aqueous solution of mixed alkali — Method of test and classification

## 1 Scope

This International Standard specifies

- a) a method for determining the resistance of glass to attack by a boiling aqueous solution of sodium carbonate and sodium hydroxide. The resistance is measured inversely by the loss in mass per unit surface area of the glass;
- b) a classification of glass according to the alkali resistance determined by the method of this International Standard.

NOTE 1 The method of test according to this International Standard is also applicable for determining the alkali resistance of glass ceramics.

## 2 Normative references

The following standards contain provisions which, through reference in this text, constitute provisions of this International Standard. At the time of publication, the editions indicated were valid. All standards are subject to revision, and parties to agreements based on this International Standard are encouraged to investigate the possibility of applying the most recent editions of the standards indicated below. Members of IEC and ISO maintain registers of currently valid International Standards.

ISO 683-13:1986, *Heat-treatable steels, alloy steels and free-cutting steels — Part 13: Wrought stainless steels.*

ISO 719:1985, *Glass — Hydrolytic resistance of glass grains at 98 °C — Method of test and classification.*

ISO 720:1985, *Glass — Hydrolytic resistance of glass grains at 121 °C — Method of test and classification.*

ISO 3696:1987, *Water for analytical laboratory use — Specification and test methods.*

ISO 3819:1985, *Laboratory glassware — Beakers.*

ISO 4799:1978, *Laboratory glassware — Condensers.*

## 3 Principle

3.1 Immersion of two sample pieces, each having a total surface area of 10 cm<sup>2</sup> to 15 cm<sup>2</sup> in a boiling aqueous solution of equal volumes of sodium carbonate,  $c(\text{Na}_2\text{CO}_3) = 0,5 \text{ mol/l}$ , and sodium hydroxide  $c(\text{NaOH}) = 1 \text{ mol/l}$ , for 3 h. Calculation of the loss in mass per unit surface area of the glass.

## 4 Reagents

During the test, unless otherwise stated, use only reagents of recognized analytical grade and only distilled water or water of equivalent purity (grade 3 water complying with the requirements of ISO 3696).

4.1 Acetone,  $\text{CH}_3\text{COCH}_3$ .

4.2 Hydrochloric acid, solution,  $c(\text{HCl}) \approx 1 \text{ mol/l}$ .

4.3 Hydrochloric acid, solution,  $c(\text{HCl}) \approx 2 \text{ mol/l}$ .

4.4 Hydrofluoric acid,  $c(\text{HF}) \approx 22 \text{ mol/l}$  (i.e.  $\approx 400 \text{ g HF/l}$  solution).

4.5 Sodium carbonate, solution,  $c(\text{Na}_2\text{CO}_3) = 0,5 \text{ mol/l} \pm 0,01 \text{ mol/l}$ , freshly prepared for each test.

4.6 Sodium hydroxide, solution,  $c(\text{NaOH}) = 1 \text{ mol/l} \pm 0,02 \text{ mol/l}$ , freshly prepared for each test.

## 5 Apparatus

5.1 Test vessel, of pure silver, alkali-resistant silver

alloy or stainless steel type 15<sup>1)</sup> complying with the requirements of ISO 683-13. A recommended test vessel, as shown in figure 1, is cylindrical with a hemispherical or flat base and has a close-fitting lid. The lid has a wide neck and is equipped on the internal surface with four hooks from which to suspend the sample pieces. A gasket, made of a material which remains inert under the test conditions, shall be used to form a seal between the lid and the body of the test vessel.

**5.2 Condenser**, of the Allihn or Liebig-West type, complying with the requirements of ISO 4799 and made of glass of hydrolytic resistance grain class HGA 1 of ISO 720<sup>2)</sup> fitted to the neck of the lid through a bung of suitable inert material which has previously been boiled for 60 min in water.

**5.3 Balance**, accurate to  $\pm 0,1$  mg.

**5.4 Desiccator**, containing a suitable drying agent.

**5.5 Measuring instruments**, suitable for measuring lengths and diameters to an accuracy of  $\pm 1$  %.

**5.6 Drying oven**, suitable for operation at a temperature of 110 °C.

**5.7 Beaker**, 1 litre capacity, complying with the requirements of ISO 3819.

**5.8 Silver wire**.

**5.9 Tongs**, tipped, if necessary, with a suitable material, e.g. plastics, silver, platinum.

**5.10 Heating bath**, fitted with a thermostat and temperature controller capable of heating and maintaining the bath liquid, e.g. glycerol, at a temperature between 110 °C and 112 °C. The heating bath shall be supplied with a stirring device or a liquid circulator and be fitted with a lid or a supply of plastics balls to completely cover the surface of the bath liquid. It shall be of sufficient capacity to allow each test vessel to be immersed in the bath liquid until the level of the liquid inside the test vessel is level with that in the heating bath and with a distance of about 60 mm all round the test vessel. These conditions shall also be fulfilled if several test vessels are simultaneously placed in the heating bath. The heating bath shall be supplied with temperature measuring devices, e.g. digital thermometers, to allow the bath liquid temperature to be measured over the range 110 °C to 112 °C.

1) The relevant constituents of steel type 15 are 18 % Cr, 10 % Ni, maximum 0,08 % C and an addition of Ti.

2) Glass of hydrolytic resistance grain class ISO 719-HGB 1 adequately meets the requirements of class HGA 1 of ISO 720.

## 6 Preparation and number of samples

### 6.1 Glass "as delivered"

Cut the sample piece or sample pieces (hereinafter referred to as "sample") from the glass into easily measurable shapes such as squares, rectangles or, from tubing, open-ended cylinders.

Each sample shall have a total surface area, surfaces plus edges, of between 10 cm<sup>2</sup> and 15 cm<sup>2</sup>. Remove any sharp angles, "hackles" or splinters by polishing the edges or bevelling the corners. Do not firepolish any part of the samples.

This concerns only samples where the new cut surface area is not more than 20 % of the total surface area. Otherwise the sample shall be submitted to the etching procedure according to 6.2 and regarded as glass "as a material".

### 6.2 Glass "as a material"

Immerse the sample(s) completely in a mixture of 1 volume of hydrofluoric acid (4.4) and 9 volumes of hydrochloric acid (4.3). Allow the samples to stand at ambient temperature for 10 min. Holding the samples in position, pour out the mixture very carefully. Rinse the sample(s) five times with distilled water (see first paragraph of clause 4).

### 6.3 Number of samples

For each test, both for glass "as delivered" or "as a material", two samples shall be tested.

## 7 Procedure

### 7.1 Number of samples in a test vessel

When "unknown" glasses are to be examined only two samples shall be tested at the same time. When glasses with a loss in mass per unit surface area not greater than 200 mg/dm<sup>2</sup> are to be examined, up to four samples of two different types of glasses may be tested simultaneously.

### 7.2 Method

Measure and calculate the total surface area of each sample, surfaces plus edges, to an accuracy of 2 % and record the value obtained.

Wash each sample, using the tongs (5.9) to hold the glass (as in subsequent operations), three times with separate portions of water (see first paragraph



of clause 4), and then rinse with acetone (4.1). Dry the samples in the drying oven (5.6) at about 110 °C for 60 min, transfer to the desiccator (5.4) and allow to cool to room temperature. Then weigh each sample to an accuracy of 0,1 mg. Record the mass,  $m_1$ , of each sample.

Transfer 800 ml of a mixture of equal volumes of the sodium carbonate (4.5) and the sodium hydroxide (4.6) solutions to each test vessel (5.1). Immerse each test vessel in the heating bath (5.10) until the level of the liquid in the test vessel is the same as that of the liquid in the bath. Fit the condenser (5.2) to the lid of each test vessel and turn on the flow of water to the condenser jacket. Cover the open surfaces of the bath liquid and activate the stirrer or liquid circulator. Heat until the liquid in each test vessel (5.1) reaches 102,5 °C ± 0,5 °C and the bath liquid temperature 110 °C to 112 °C, if necessary avoiding bumping in the test vessel by adding boiling aids, e.g. pieces of silver wire or polytetrafluoroethylene (PTFE).

Raise the lids and condensers from the test vessels, suspend the samples by silver wire slings (5.8) from the hooks on the lids of the test vessels, fit the gasket on the flange of the body of each test vessel, then immerse the samples in the boiling test solution so that all samples are immersed completely. Ensure that no contact is made between the samples or with the wall of the test vessels, and that the lid and body of the test vessel are clamped sufficiently tightly on the gasket to prevent losses of vapour during the heating period.

Maintain the temperature of 102,5 °C ± 0,5 °C in the test vessels for 3 h ± 2 min from the time of immersion of the samples.

Remove the samples from the boiling solution and submerge them quickly three times in 500 ml of the hydrochloric acid solution (4.2), contained in the beaker (5.7). Then wash three times with water and finally rinse with acetone (4.1). Dry the sample in the drying oven (5.6) at about 110 °C for 60 min, transfer to the desiccator (5.4) and allow to cool to room temperature. Weigh each sample to an accuracy of 0,1 mg. Record the mass,  $m_2$ , of each sample. Calculate the loss in mass of each sample.

## 8 Expression of results

### 8.1 Calculation

From each of the results obtained, calculate and report the loss in mass per total surface area of each sample,  $\rho_A$ , in milligrams per square decimetre, from the following numerical equation

$$\rho_A = \frac{100(m_1 - m_2)}{A}$$

where

- $m_1$  is the initial mass, in milligrams, of the sample;
- $m_2$  is the final mass, in milligrams, of the sample;
- $A$  is the total surface area, in square centimetres, of the sample.

Calculate the arithmetic mean of the values obtained.

If the values differ by more than 10 % from the arithmetic mean, repeat the test, using two new samples and fresh solutions.

### 8.2 Classification

Glass shall be classified as shown in table 1, according to the loss in mass per total surface area, expressed in milligrams per square decimetre, when tested for 3 h by the method specified in this International Standard.

Table 1 — Limit values in the alkali resistance test

Class	Characteristics	Loss in mass per total surface area after 3 h mg/dm <sup>2</sup>
A1	Low attack	Up to 75
A2	Slight attack	Above 75 up to 175
A3	High attack	Above 175

### 8.3 Designation

For convenience of reference to the alkali resistance of glass complying with the classification of this International Standard, the use of the following designation is recommended:

*Example:* For a glass with a loss in mass per total surface area of 90 mg/dm<sup>2</sup> (class A2):

**Glass, alkali resistance class ISO 695 - A2**

## 9 Precision

Repeatability value:  $r = 16$  mg/dm<sup>2</sup>

Reproducibility value:  $R = 25$  mg/dm<sup>2</sup>

NOTE 2 The precision data are calculated from the results obtained in an inter-laboratory test in which seven laboratories had carried out 87 single determinations resulting in an arithmetic mean of  $\rho_A = 163$  mg/dm<sup>2</sup> for the glass tested.

## 10 Test report

The test report shall include the following details:

- a) a reference to this International Standard;
- b) an identification of the sample;
- c) a statement as to whether the test was applied to glass "as delivered" or to glass "as a material" after etching the surface;
- d) the total surface area, in square centimetres, of the sample tested, to the nearest 0,1 cm<sup>2</sup>;
- e) the loss in mass per total surface area of the glass, in milligrams per square decimetre, to the nearest 1 mg/dm<sup>2</sup>, mean value;
- f) alkali resistance class A (designation);
- g) any unusual features noted during the determination.

Dimensions in millimetres

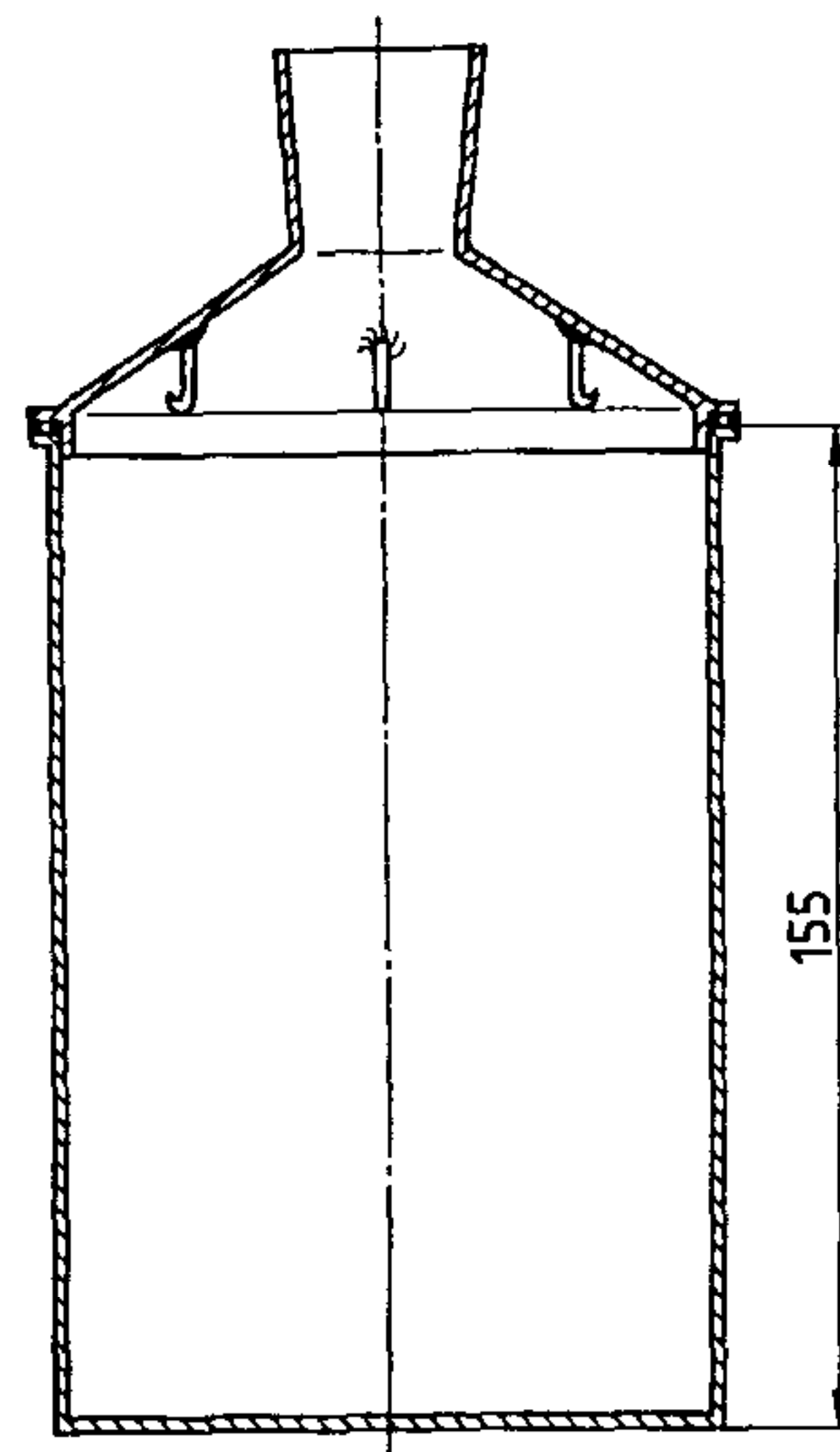
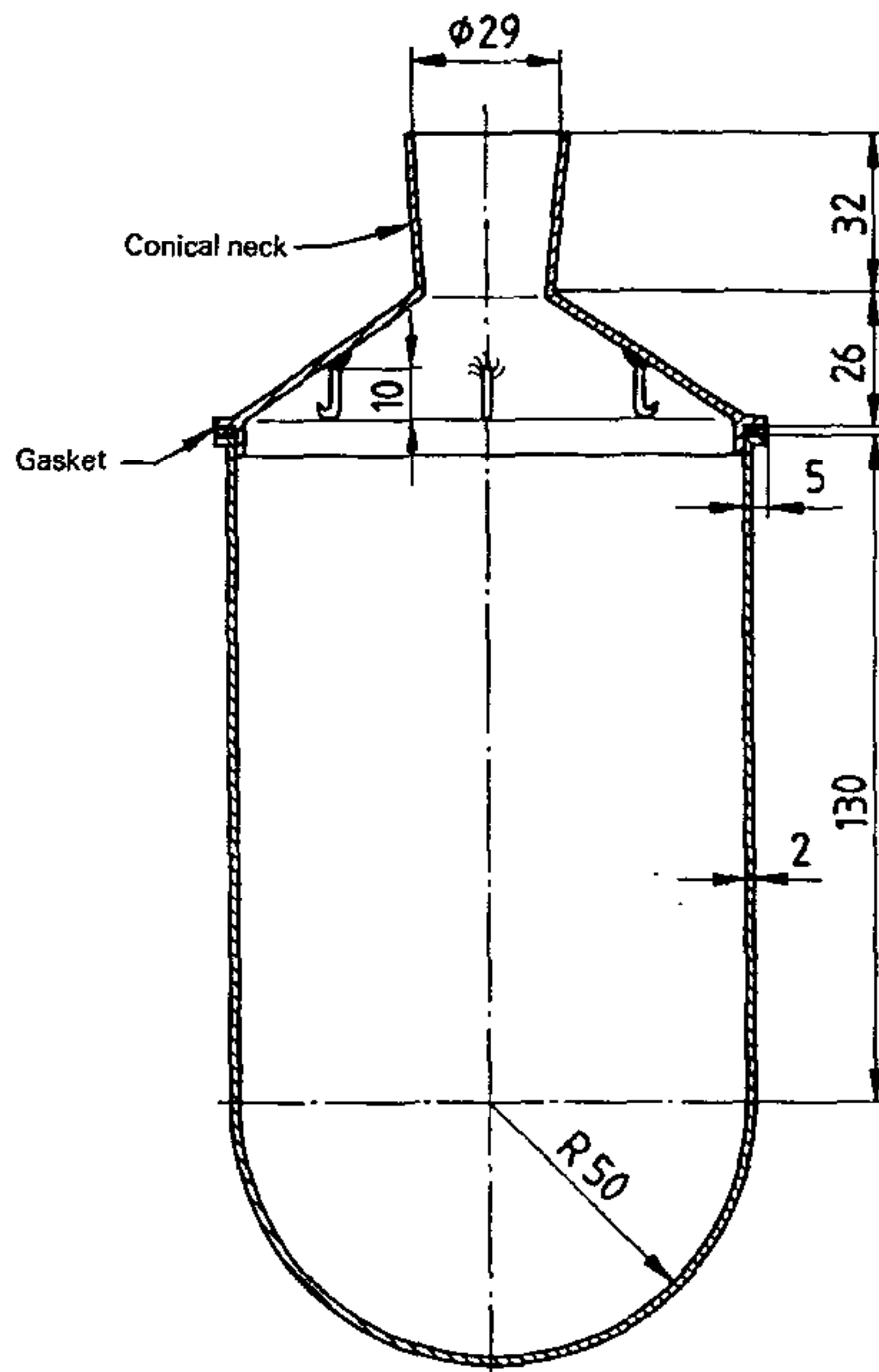

Other dimensions and specifications as in the gauge figure

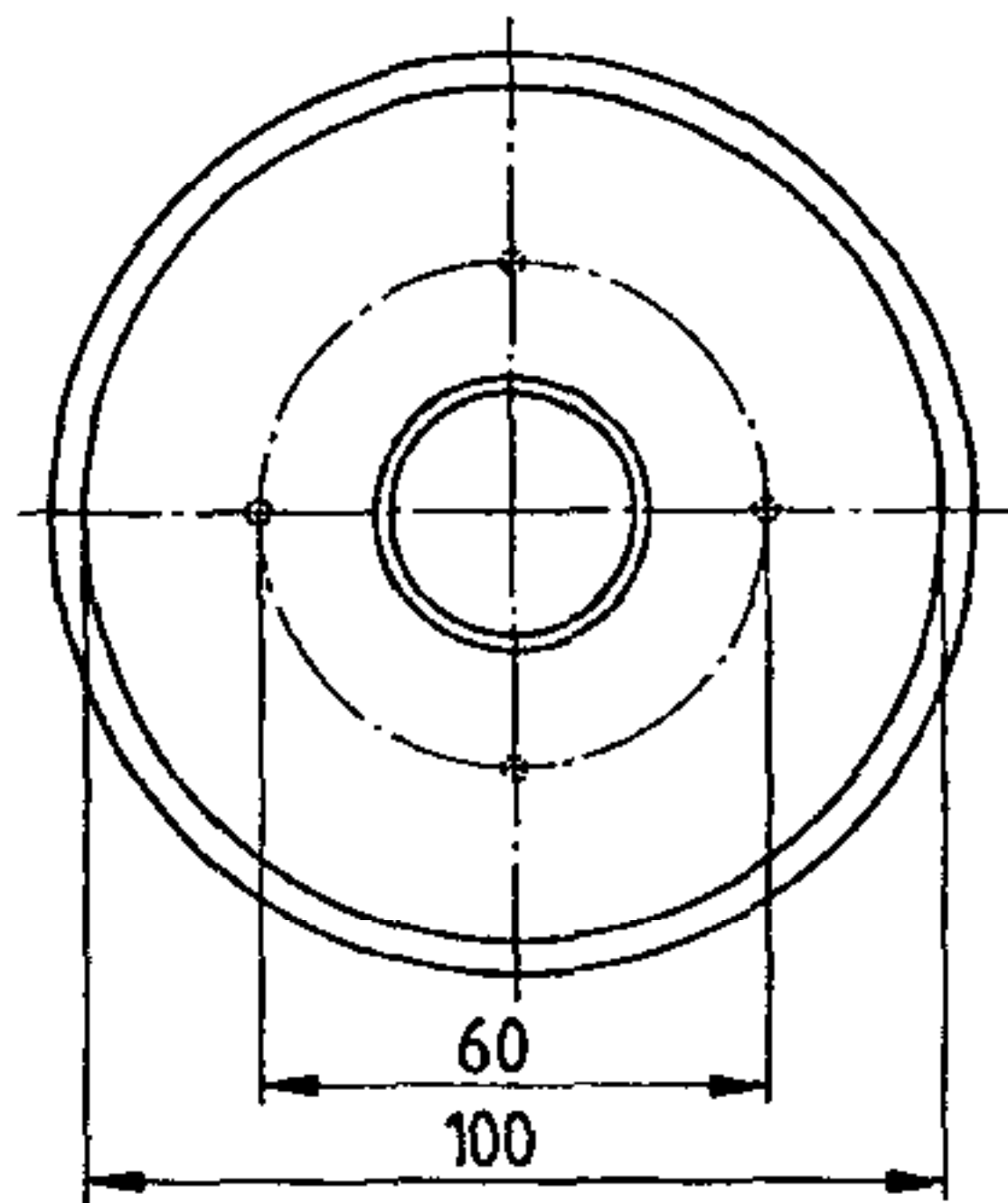

View of lid from above, showing position of hooks

**Execution:**

- 4 hooks soldered to the lid;
- 1 flange with ground flat surface, fixed to the lid.

**Figure 1 — Examples of suitable test vessels with a hemispherical and a flat base**

**ISO 695:1991(E)**

---

---

**UDC 542.231:620.193.42**

**Descriptors:** glass, alkali resistance, classification, designation, tests, alkali resistance tests, boiling temperature tests.

**Price based on 5 pages**

---

---