

# INTERNATIONAL STANDARD

**ISO  
683-9**

First edition  
1988-12-01



---

INTERNATIONAL ORGANIZATION FOR STANDARDIZATION  
ORGANISATION INTERNATIONALE DE NORMALISATION  
МЕЖДУНАРОДНАЯ ОРГАНИЗАЦИЯ ПО СТАНДАРТИЗАЦИИ

---

## **Heat-treatable steels, alloy steels and free-cutting steels —**

### **Part 9 : Wrought free-cutting steels**

*Aciers pour traitement thermique, aciers alliés et aciers pour décolletage —*

*Partie 9: Aciers corroyés pour décolletage*

Reference number  
ISO 683-9:1988 (E)

## Foreword

ISO (the International Organization for Standardization) is a worldwide federation of national standards bodies (ISO member bodies). The work of preparing International Standards is normally carried out through ISO technical committees. Each member body interested in a subject for which a technical committee has been established has the right to be represented on that committee. International organizations, governmental and non-governmental, in liaison with ISO, also take part in the work. ISO collaborates closely with the International Electrotechnical Commission (IEC) on all matters of electrotechnical standardization.

Draft International Standards adopted by the technical committees are circulated to the member bodies for approval before their acceptance as International Standards by the ISO Council. They are approved in accordance with ISO procedures requiring at least 75 % approval by the member bodies voting.

International Standard ISO 683-9 was prepared by Technical Committee ISO/TC 17, *Steel*.

It cancels and replaces ISO Recommendation R 683-9 : 1970, of which it constitutes a technical revision.

Users should note that all International Standards undergo revision from time to time and that any reference made herein to any other International Standard implies its latest edition, unless otherwise stated.

# Heat-treatable steels, alloy steels and free-cutting steels —

## Part 9 : Wrought free-cutting steels

### 0 Introduction

When preparing this part of ISO 683, it was very difficult to come to international agreements on chemical composition of free-cutting steels. The types of steel given in this part of ISO 683 are typical grades only and other grades may be covered by national standards.

### 1 Scope and field of application

1.1 This part of ISO 683 gives the technical delivery requirements for

- semi-finished products, e.g. blooms, billets, slabs,
- bars,
- wire rod and
- bright steel

manufactured from the free-cutting steels listed in table 3 and supplied in one of the treatment conditions given for the different types of products in table 1, lines 2 and 3, and in one of the surface conditions given in table 2.

This part of ISO 683 covers three groups of wrought free-cutting steels for mechanical purposes as listed in table 3, namely

- a) not intended for heat treatment,
- b) suitable for case-hardening,
- c) suitable for quenching and tempering.

NOTE — Related International Standards are given in annex C.

1.2 In special cases, variations in these technical delivery requirements or additions to them may form the subject of an agreement at the time of enquiry and order (see annex B).

1.3 In addition to this part of ISO 683, the general technical delivery requirements of ISO 404 are applicable.

### 2 References

ISO 377, *Wrought steel — Selection and preparation of samples and test pieces.*

ISO 404, *Steel and steel products — General technical delivery requirements.*

ISO 683, *Heat-treatable steels, alloy steels and free-cutting steels*

— *Part 1: Direct-hardening unalloyed and low-alloyed wrought steel in form of different black products.*

— *Part 11: Wrought case-hardening steels.*

ISO 1035, *Hot-rolled steel bars*

— *Part 1: Dimensions of round bars.*

— *Part 2: Dimensions of square bars.*

— *Part 3: Dimensions of flat bars.*

— *Part 4: Tolerances.*

ISO 6506, *Metallic materials — Hardness test — Brinell test.*

ISO 6892, *Metallic materials — Tensile testing.*

ISO 6929, *Steel products — Definitions and classification.*

### 3 Definitions

3.1 **product forms**: See ISO 6929.

3.2 **free-cutting steels**: In the sense of this part of ISO 683, steels characterized by good machinability, i.e. high metal removal rate, essentially obtained by higher than normal contents of sulfur, or sulfur and lead.

## 4 Ordering and designation

The designation of the product in an order shall cover the following:

- a) the designation of the product form (bloom, bar, wire rod, etc.) followed by
  - either the designation of the dimensional standard and the dimensions and tolerances selected from this (see 5.5),
  - or the designation of the drawing or any other document covering the dimensions and tolerances required for the product;
- b) if a surface condition other than "hot worked" or a special surface quality is required:
  - the surface condition (see table 2) and
  - the surface quality (see 5.4);
- c) a description of the steel comprising
  - 1) a reference to this part of ISO 683;
  - 2) the designation of the steel type given in table 3;
  - 3) if a treatment condition other than the untreated condition is required, the symbol for this other condition (see table 1, column 3);
  - 4) if a document is required, the symbol for the required type of document (see table 10);
  - 5) if any supplementary requirements are to be complied with, the symbol and, where necessary, the details of each supplementary requirement (see annex B).

*Example:*

To be ordered are:

Hot-rolled round bars,

according to ISO 1035-1,

with a nominal diameter of 40,0 mm,

with a nominal length of 8 000 mm,

with a diameter tolerance of  $\pm 0,40$  mm (= class S of ISO 1035-4),

with a length tolerance of  $+100^0$  mm (= class L2 of ISO 1035-4),

all other tolerances as given in ISO 1035-4, for normal cases.

**Surface**

peeled (symbol PE, see table 2).

**Steel**

according to this part of ISO 683,

type 35 S 20 (see table 3),

treatment condition: untreated (no symbol or U, see table 1),

with an inspection certificate of type IC (see table 10).

Designation:

Rounds: ISO 1035-1 – 40,0 S × 8 000 L2

Surface: PE

Steel: ISO 683-9 – 35 S 20 – U – IC

## 5 Requirements

### 5.1 Manufacturing process

5.1.1 The manufacturing process for the steel and for the products is, with the restrictions given by the requirements in 5.1.2 to 5.1.3, left to the discretion of the manufacturer.

#### 5.1.2 Treatment and surface condition at delivery

In accordance with the agreements at the time of enquiry and order, the products shall be delivered in one of the treatment and surface conditions listed in tables 1 and 2 respectively.

#### 5.1.3 Cast separation

The steels shall be delivered separated by casts.

### 5.2 Chemical composition, hardness and mechanical properties

5.2.1 Table 1 gives a survey of combinations of usual treatment conditions at delivery, product forms and requirements according to the tables 3 to 7 (chemical composition, maximum hardness, mechanical properties).

5.2.2 Mechanical properties for reference test bars of case-hardening steels in the simulated case-hardened condition are given in table 6 for guidance.

### 5.3 Technological properties

#### 5.3.1 Machinability

The steels covered by this part of ISO 683 have good machinability and chip-breaking characteristics. However, the machinability decreases with increasing carbon, silicon and manganese contents, while cold-reduction improves the machinability of the steels not intended for heat-treatment and steels 10 S 20 and 10 SPb 20.

#### 5.3.2 Weldability

Because of their high sulfur and phosphorus content, free-cutting steels are not normally recommended for welding.

### 5.4 Surface quality

5.4.1 All products shall have a workmanlike finish.

**5.4.2** Minor surface imperfections, which may also occur under normal manufacturing conditions, such as scores originating in the case of black steel from rolled-in scale, are not to be regarded as defects.

**5.4.3** As long as no International Standard on the surface quality of steel products is available, detailed requirements referring to this characteristic shall, where appropriate, be agreed at the time of enquiry and order.

#### NOTES

1 For bars and wire rod included in this part of ISO 683, a separate International Standard on surface quality is under consideration.

2 It is more difficult to detect and eliminate surface discontinuities in coiled products than in cut lengths. This should be taken into account when agreements on surface quality are made.

**5.4.4** Removal of surface imperfections by welding is not permitted.

Pending publication of a separate International Standard, the kind and permissible depth of surface imperfections for removal should, where appropriate, be agreed at the time of enquiry and order.

## 5.5 Shape, dimensions and tolerances

The shape, dimensions and tolerances of the products shall comply with the requirements agreed at the time of enquiry and order. The agreements shall, as far as possible, be based on corresponding International Standards, otherwise on suitable national standards.

NOTE — The following International Standard covers dimensions and/or tolerances for products covered by this part of ISO 683:

- for bars: ISO 1035 parts 1 to 4.

## 6 Inspection, testing and conformity of products

### 6.1 Inspection and testing procedures and types of document

**6.1.1** Table 10 gives a survey of the inspection procedures and the types of document in ISO 404 which may be agreed at the time of enquiry and order for deliveries according to this part of ISO 683.

**6.1.2** If in accordance with the agreements at the time of enquiry and order a test report (TR) is to be provided, this shall include

- a) a statement that the material complies with the requirements of the order, and
- b) the results of the cast analysis for all elements specified for the steel type supplied.

**6.1.3** If in accordance with the agreements in the order an inspection certificate (IC or ICP) or an inspection report (IR) (see table 10) is to be provided, the specific inspections and tests described in 6.2 shall be carried out and their results shall be certified in the document.

In addition the document shall include

- a) for all elements specified for the steel type concerned, the results of the cast analysis given by the manufacturer;
- b) the results of all inspections and tests made necessary by supplementary requirements (see annex B);
- c) the symbol letters or numbers relating the test certificates, the test pieces and products to each other.

## 6.2 Specific inspection and testing

### 6.2.1 Verification of the hardness and mechanical properties

**6.2.1.1** The hardness requirements and/or mechanical properties given for the relevant treatment condition in table 1, column 8, sub-column 2, shall be verified, with the following exception. The requirements given in footnotes 1 and 2 to table 1 (mechanical properties of reference test pieces), shall only be verified if the supplementary requirement given in annex B, clause B.1 or B.2, is invoked.

**6.2.1.2** The amount of testing, the sampling conditions and the test methods to be applied for the verification of compliance with the requirements shall be in accordance with the prescriptions in table 11.

### 6.2.2 Visual and dimensional inspection

A sufficient number of products shall be inspected to ensure compliance with the specification.

### 6.2.3 Retests

**6.2.3.1** Where for one or more test units one or more tests give unsatisfactory results, the manufacturer has the choice of withdrawing the test units concerned (for example for re-treatment or sorting in accordance with ISO 404) or maintaining them. If they are maintained, retests shall be carried out according to the following rules.

**6.2.3.2** If — as in the case of product analysis (see annex B, clause B.3) — only one test of the type concerned was carried out on the sample concerned and gave the unsatisfactory result, two new tests of the same type shall be carried out.

**6.2.3.3** If the test unit consists of more than one product and if the product from which the unsatisfactory test result stems is not withdrawn from the test unit, one of the two new tests shall be made on test pieces taken from the sample or product originally tested.

**6.2.3.4** All retests shall give satisfactory results. Otherwise the test unit concerned shall be rejected.

## 7 Marking

The manufacturer shall mark the products or bundles or boxes containing the products in a suitable way, so that the identification of the cast, the steel type and the origin of the delivery is possible (see annex B, clause B.4).

**Table 1 – Combinations of usual heat-treatment conditions at delivery, product forms and requirements according to tables 3 to 7**

1	2	3	4	5	6	7	8			
1	Heat-treatment condition at delivery	Symbol	x = Applicable for				Applicable requirements			
			billets blooms slabs	bars	wire rod	bright steel	8.1	8.2		
							Normal requirement class	Special requirement class		
		8.2.1	8.2.2							
2	Untreated (as rolled or as peeled)	None or U	x	x	x	x	Chemical composition according to tables 3 + 4	Chemical composition according to tables 3 + 4	Maximum Brinell hardness according to	table 5 in the case of steels not intended for heat-treatment or table 6 in the case of case-hardening steels <sup>1)</sup> or table 7 in the case of steels for quenching and tempering <sup>2)</sup>
3	Cold drawn	C	—	—	—	x			Mechanical properties in the cold-drawn condition according to	table 5 in the case of steels not intended for heat-treatment or table 6 in the case of case-hardening steels <sup>1)</sup> or table 7 in the case of steels for quenching and tempering <sup>2)</sup>
4	Others	Other treatment conditions, for example the stress relieved condition or the quenched + tempered condition, may be agreed at the time of enquiry and order.								

1) Verification of the values given in table 6 for simulated-hardened reference test bars may be agreed at the time of enquiry and order (see annex B, clause B.2).

2) The mechanical properties specified in table 7 for the quenched + tempered condition shall be achievable after appropriate heat treatment if so agreed at the time of enquiry and order (see annex B, clause B.1).

**Table 2 – Surface condition at delivery**

1	2	3	4	5	6	7	8
1	Surface condition at delivery		x = In general applicable for				Notes
			Symbol	semi-finished products	bars	wire rods	
2	As hot worked	None or HW	x	x	x	—	
3	HW + peeled	PE	—	—	—	x	1)
4	Cold drawn	C	—	—	—	x	
5	Others						

1) In addition, it may be agreed that the products are oiled.

Table 3 — Types of steel, chemical composition (applicable to cast analysis)<sup>1)</sup>

Type of steel <sup>2)</sup>		C %	Si %	Mn %	P %	S %	Pb %
<b>Steels not intended for heat treatment</b>							
<b>9 S 20</b>	1	max. 0,13	max. 0,05 <sup>3)</sup>	0,60 to 1,20 <sup>4)</sup>	max. 0,11 <sup>5)</sup>	0,15 to 0,25	—
<b>11 SMn 28</b>	2	max. 0,14	max. 0,05 <sup>3)</sup>	0,90 to 1,30	max. 0,11 <sup>5)</sup>	0,24 to 0,33	—
<b>11 SMnPb 28</b>	2 Pb	max. 0,14	max. 0,05 <sup>3)</sup>	0,90 to 1,30	max. 0,11 <sup>5)</sup>	0,24 to 0,33	0,15 to 0,35 <sup>6)</sup>
<b>12 SMn 35</b>	3	max. 0,15	max. 0,05 <sup>3)</sup>	1,00 to 1,50	max. 0,11 <sup>5)</sup>	0,30 to 0,40	—
<b>12 SMnPb 35</b>	3 Pb	max. 0,15	max. 0,05 <sup>3)</sup>	1,00 to 1,50	max. 0,11 <sup>5)</sup>	0,30 to 0,40	0,15 to 0,35 <sup>6)</sup>
<b>Case-hardening steels<sup>7)</sup></b>							
<b>10 S 20</b>	4	0,07 to 0,13	0,15 to 0,40	0,70 to 1,10	max. 0,06	0,15 to 0,25	—
<b>10 SPb 20</b>	4 Pb	0,07 to 0,13	0,15 to 0,40	0,70 to 1,10	max. 0,06	0,15 to 0,25	0,15 to 0,35 <sup>6)</sup>
<b>17 SMn 20</b>	(6)	0,14 to 0,20	0,15 to 0,40	1,20 to 1,60	max. 0,06	0,15 to 0,25	—
<b>Direct-hardening steels<sup>7)</sup></b>							
<b>35 S 20</b>	7	0,32 to 0,39	0,15 to 0,40	0,70 to 1,10	max. 0,06	0,15 to 0,25	8)
<b>35 SMn 20</b>	8	0,32 to 0,39	0,15 to 0,40	0,90 to 1,40	max. 0,06	0,15 to 0,25	8)
<b>44 SMn 28</b>	—	0,40 to 0,48	0,15 to 0,40	1,30 to 1,70	max. 0,06	0,24 to 0,33	8)
<b>46 S 20</b>	10	0,42 to 0,50	0,15 to 0,40	0,70 to 1,10	max. 0,06	0,15 to 0,25	8)

1) Elements not quoted in this table should not be intentionally added to the steel without the agreement of the purchaser, other than for the purpose of finishing the heat. However, unless otherwise agreed, the manufacturer may add elements such as Ca, Te, etc., for the purpose of improving the machinability.

2) Numbers used previously in ISO/R 683-9 : 1970 are given in the right-hand column.

3) Since silicon has an adverse effect on machinability, it is not intentionally added to specified limits.

4) An Mn content of 0,50 % min. may be agreed at the time of enquiry and order.

5) At the time of enquiry and order, it may be agreed that either a grade with 0,06 to 0,11 % P or a grade with max. 0,05 % P shall be delivered.

6) Applicable to product analysis.

7) Where toughness is of importance, steels with a lower sulfur range or other means, for example lead addition or a controlled shape of the sulfides, may be employed (see footnote 5 to table 3 of ISO 683-1 and footnote 3 to table 3 of ISO 683-11).

8) Lead additions may be agreed at the time of enquiry and order.

Table 4 — Permissible deviations between specified analysis and product analysis

Element	Permissible maximum content according to cast analysis % (m/m)	Permissible deviations <sup>1)</sup> % (m/m)
<b>C</b>	< 0,30	± 0,02
	> 0,30 < 0,50	± 0,03
<b>Si</b>	< 0,05	± 0,01
	> 0,05 < 0,40	± 0,03
<b>Mn</b>	< 1,00	± 0,04
	> 1,00 < 1,70	± 0,06
<b>P</b>	< 0,06	± 0,008
	> 0,06 < 0,11	± 0,02
<b>S</b>	< 0,33	± 0,03 <sup>2)</sup>
	> 0,33 < 0,40	± 0,04

1) ± means that in one cast the deviation may occur over the upper value or under the lower value of the specified range in table 3, but not both at the same time.

2) A permissible deviation  $\begin{matrix} + 0,05 \\ - 0,03 \end{matrix}$  % S for steel type 9 S 20 may be agreed at the time of enquiry and order.

**Table 5 – Mechanical properties of free-cutting steels not intended for heat-treatment<sup>1)</sup>**

Type of steel	Diameter	As rolled or as peeled	Cold drawn <sup>2)</sup>		
		Hardness	$R_e$ min.	$R_m$	$A$ min.
	mm	HB max.	N/mm <sup>2</sup>	N/mm <sup>2</sup>	%
9 S 20	< 16	163	390	490 to 790	8
	> 16 < 40	159	355	440 to 740	9
	> 40 < 63	159	295	390 to 690	10
	> 63 < 100	149	235	360 to 610	11
11 SMn 28	< 16	170	410	510 to 810	7
	> 16 < 40	159	375	460 to 760	8
11 SMnPb 28	> 40 < 63	159	305	410 to 710	9
	> 63 < 100	156	245	380 to 630	10
12 SMn 35	< 16	174	430	540 to 840	7
	> 16 < 40	163	390	490 to 790	8
12 SMnPb 35	> 40 < 63	159	315	430 to 730	9
	> 63 < 100	156	255	390 to 640	10

1)  $R_e$  = yield stress (0,2 % proof stress);  
 $R_m$  = tensile strength;  
 $A$  = percentage elongation after fracture ( $l_0 = 5 d_0$ ).

2) The mechanical properties in the cold-drawn condition can vary depending on the starting properties of the bars and on the amount of cold drawing. Therefore, these values shall be regarded as applicable unless otherwise agreed. If such agreements are made, it shall be taken into account that very high cold-drawing rates may adversely affect the machinability.

**Table 6 – Mechanical properties of case-hardening free-cutting steels<sup>1)</sup>**

Type of steel	Diameter	As rolled or As peeled	Cold drawn <sup>2)</sup>		Simulated case hardened <sup>3)</sup>			
		Hardness	$R_m$	$A$ min.	Test bar	$R_e$ min.	$R_m$	$A$ min.
	mm	HB max.	N/mm <sup>2</sup>	%	mm	N/mm <sup>2</sup>	N/mm <sup>2</sup>	%
10 S 20 10 SPb 20	< 16	159	490 to 790	8	16 30	270 250	450 to 800 400 to 700	12 13
	> 16 < 40	149	440 to 740	9				
	> 40 < 63	149	390 to 690	10				
17 SMn 20	< 16	179	530 to 830	6	16 30	500 400	750 to 1 100 600 to 900	9 10
	> 16 < 40	170	490 to 790	7				
	> 40 < 63	170	470 to 770	8				

1)  $R_e$  = yield stress (0,2 % proof stress);  
 $R_m$  = tensile strength;  
 $A$  = percentage elongation after fracture ( $l_0 = 5 d_0$ ).

2) The mechanical properties in the cold-drawn condition can vary depending on the starting properties of the bars and on the amount of cold drawing. Therefore, these values shall be regarded as applicable unless otherwise agreed. If such agreements are made, it shall be taken into account that very high cold-drawing rates may adversely affect the machinability.

3) The values are for guidance only.



Table 7 – Mechanical properties of direct-hardening free-cutting steels<sup>1)</sup>

Type of steel	Diameter	As rolled or As peeled	Cold drawn <sup>2)</sup>		Quenched and tempered <sup>3)</sup>		
		Hardness	$R_m$	$A$ min.	$R_e$ min.	$R_m$	$A$ min.
	mm	HB max.	N/mm <sup>2</sup>	%	N/mm <sup>2</sup>	N/mm <sup>2</sup>	%
35 S 20	< 16	197	590 to 880	6	390	570 to 770	14
	> 16 < 40	192	540 to 740	8	335	540 to 740	16
	> 40 < 63	192	510 to 710	9	305	490 to 690	17
35 SMn 20	< 16	205	610 to 900	6	420	620 to 820	14
	> 16 < 40	200	580 to 780	8	365	590 to 790	16
	> 40 < 63	200	560 to 760	9	335	540 to 740	17
44 SMn 28	< 16	241	750 to 1 040	5	530	750 to 950	10
	> 16 < 40	241	720 to 920	7	490	710 to 910	11
	> 40 < 63	241	700 to 900	8	450	670 to 870	12
46 S 20	< 16	229	690 to 980	5	450	650 to 850	11
	> 16 < 40	223	640 to 830	7	380	610 to 810	13
	> 40 < 63	223	610 to 800	8	345	570 to 770	14

1)  $R_e$  = yield stress (0,2 % proof stress);

$R_m$  = tensile strength;

$A$  = percentage elongation after fracture ( $l_0 = 5 d_0$ ).

2) The mechanical properties in the cold-drawn condition can vary depending on the starting properties of the bars and on the amount of cold drawing. Therefore, these values shall be regarded as applicable unless otherwise agreed. If such agreements are made, it shall be taken into account that very high cold-drawing rates may adversely affect the machinability.

3) When mechanical properties are specified for the quenched and tempered and subsequently cold-reduced condition, values for these shall be agreed between the purchaser and the supplier.

Table 8 – Conditions for heat treating of case-hardening free-cutting steels<sup>1)</sup>

Type of steel	Carburizing temperature <sup>2) 3)</sup>	Direct and simple hardening temperature	Double hardening		Quenching agent	Tempering <sup>5)</sup>
	°C	°C	Core hardening temperature <sup>3)</sup>	Case hardening temperature		°C
10 S 20 10 SPb 20 17 SMn 20	880 to 980	830 to 870	880 to 920	780 to 820	4)	150 to 200

1) The temperatures given for carburizing, direct and simple hardening, core hardening, case hardening and tempering are for guidance; the actual temperatures chosen shall be those that will give the properties required.

2) The carburizing temperature will depend on the chemical composition of the steel, the mass of the product, and the carburizing medium. If the steels are direct hardened, in general a temperature of 950 °C is not exceeded. For special procedures, for example under vacuum, higher temperatures, for example 1 020 to 1 050 °C, are not unusual.

3) If the steels are direct hardened and if there is a danger of distortion, they shall be quenched from a temperature between the core hardening and case hardening temperatures.

4) The kind of quenching agent depends for example on the shape of the products, the cooling conditions and the quantity of furnace filling.

5) Time for tempering as a guide : 1 h minimum.

**Table 9 – Conditions for treating direct-hardening free-cutting steels<sup>1)</sup>**

Type of steel	Normalizing °C	Quenching <sup>2)</sup>		Tempering <sup>3)</sup> °C
		°C	medium	
<b>35 S 20, 36 SMn 20</b>	860 to 890	860 to 890	Water or oil	540 to 680
<b>44 SMn 28</b>	840 to 870	840 to 870	Oil or water	540 to 680
<b>46 S 20</b>	840 to 870	840 to 870	Oil or water	540 to 680

- 1) The temperatures are for guidance, but the actual temperatures chosen shall be those that will give the properties required.
- 2) Time for austenitizing as a guide: 0,5 h minimum.
- 3) Time for tempering as a guide: 1 h minimum.

**Table 10 – Applicable inspection procedures and types of document**

1	2	3
Symbol	Inspection and testing procedure	Type of document
—	Non-specific testing and inspection <sup>1)</sup>	None
SC		Statement of compliance
TR		Test report
IC	Specific testing and inspection <sup>2)</sup> by the competent department at the manufacturer's works	Inspection certificate signed by a representative of the competent department at the manufacturer's works
ICP	Specific testing and inspection <sup>2)</sup> in the presence of the purchaser or a representative designated by him	Inspection certificate signed by the purchaser or a representative designated by him
IR		Inspection report signed by the manufacturer and the purchaser or his representative

- 1) Non-specific inspection and testing is inspection and testing carried out by the manufacturer in accordance with his own procedures, on products made by the same manufacturing process, but not necessarily on the products actually supplied.
- 2) Specific inspection and testing means the inspection and testing procedure carried out on the products to be supplied, in order to verify whether these products comply with the requirements of the order.

Table 11 — Test conditions for verification of compliance with the various requirements

NOTE — Verification of the requirements is only necessary if an inspection certificate or an inspection report is ordered and if the requirement is applicable according to table 1, column 8.

1	2		3	4	5	6	7
No	Requirements		Amount of testing			Sampling <sup>2)</sup>	Test method
	see table		Test unit <sup>1)</sup>	Number of sample products per test unit	tests per sample product		
1	Chemical composition	3 + 4	C	(The cast analysis is given by the manufacturer; for product analysis, see annex B, clause B.3)			
2	Hardness in the untreated condition (as rolled or as peeled)	5 + 6 + 7	C + D + T	1	1	In cases of dispute, the hardness shall be measured, if possible, at the circumference of the product at a distance of $1 \times$ thickness from one end and in cases of products with square or rectangular cross-section at a distance of $0,25 \times w$ (width of the product) from one longitudinal edge.	According to ISO 6506
3	Mechanical properties of products in the cold-drawn or quenched and tempered condition	5 + 6 + 7	C + D + T	1 <sup>3)</sup>	1	The test pieces for the tensile test shall be taken in accordance with figure 1.	The tensile test shall be carried out in accordance with ISO 6892 on proportional test pieces having a gauge length of $L_0 = 5,65 S_0$ . ( $S_0$ = area of the cross-section of the test piece.)

1) The tests shall be carried out separately for each cast as indicated by "C", each dimension as indicated by "D" and each heat treatment batch as indicated by "T".

Products with different thicknesses may be grouped if the thicknesses lie in the same dimensional range for mechanical properties and if the differences in thickness do not affect the properties. In cases of doubt, the thinnest and the thickest product shall be tested.

2) The general conditions for selection and preparation of test samples and test pieces shall be in accordance with ISO 377.

3) If the products are continuously heat treated, one sample product shall be taken for each 25 t or part thereof, but at least one sample product for each cast.

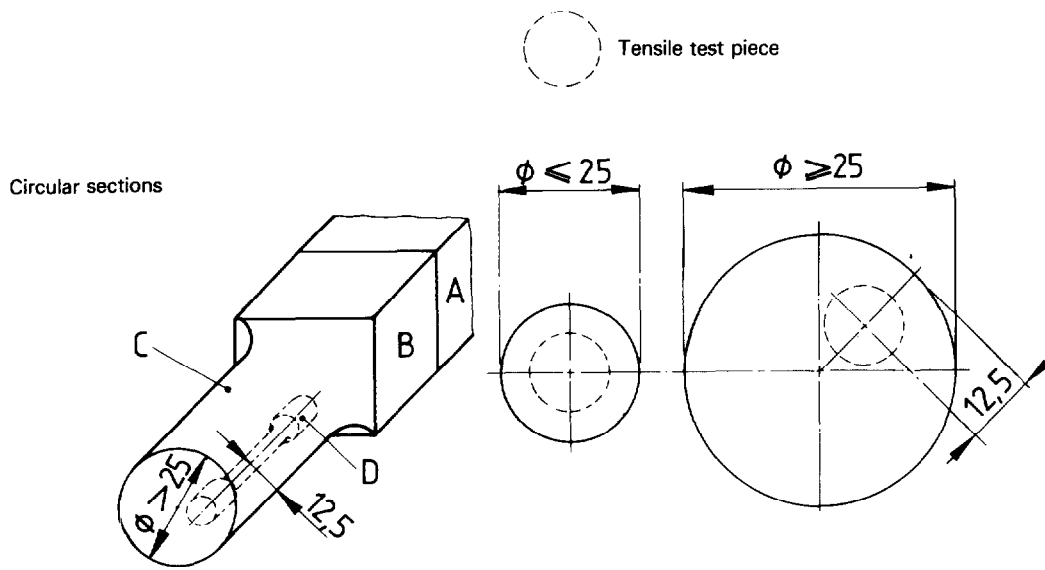

- A = Sample product
- B = Test sample
- C = Test bar (the piece after reduction to the size in which it is to be heat treated)
- D = Test piece

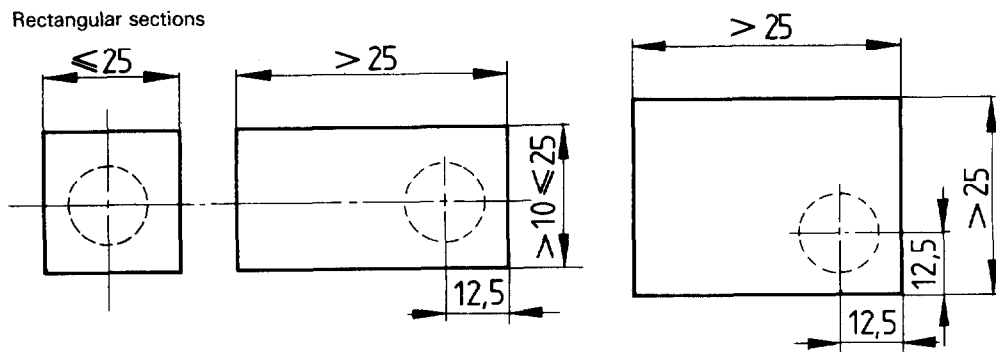

Figure 1 – Location of the test pieces in the products

## Annex A

### Ruling sections for the mechanical properties

(This annex forms an integral part of the Standard.)

#### A.1 Definition

**ruling section of a product:** That section for which the specified mechanical properties shall apply.

Independent of the actual shape and dimensions of the cross-section of the product, the size of its ruling section is always given by a diameter. This corresponds to the diameter of an "equivalent round bar". That is a round bar which, at the position of its cross-section specified for taking the test pieces for the mechanical tests, will, when being cooled from the austenitizing temperature, show the same cooling rate as the actual ruling section of the product concerned at its position for taking the test pieces.

#### A.2 Determination of the diameter of the ruling section

**A.2.1** If the test pieces are taken from products with simple cross-sections and from positions with quasi two-dimensional heat flow, the following shall apply.

**A.2.1.1** For round bars, the nominal diameter of the product (not comprising the machining allowances) shall be taken as the diameter of the ruling section.

**A.2.1.2** For hexagons and octagons, the nominal distance between two opposite sides of the cross-section shall be taken as the diameter of the ruling section.

**A.2.1.3** For square and rectangular bars, the diameter of the ruling section shall be determined as shown in the example in figure 2.

**A.2.2** For other product forms, the ruling section shall be agreed at the time of enquiry and order.

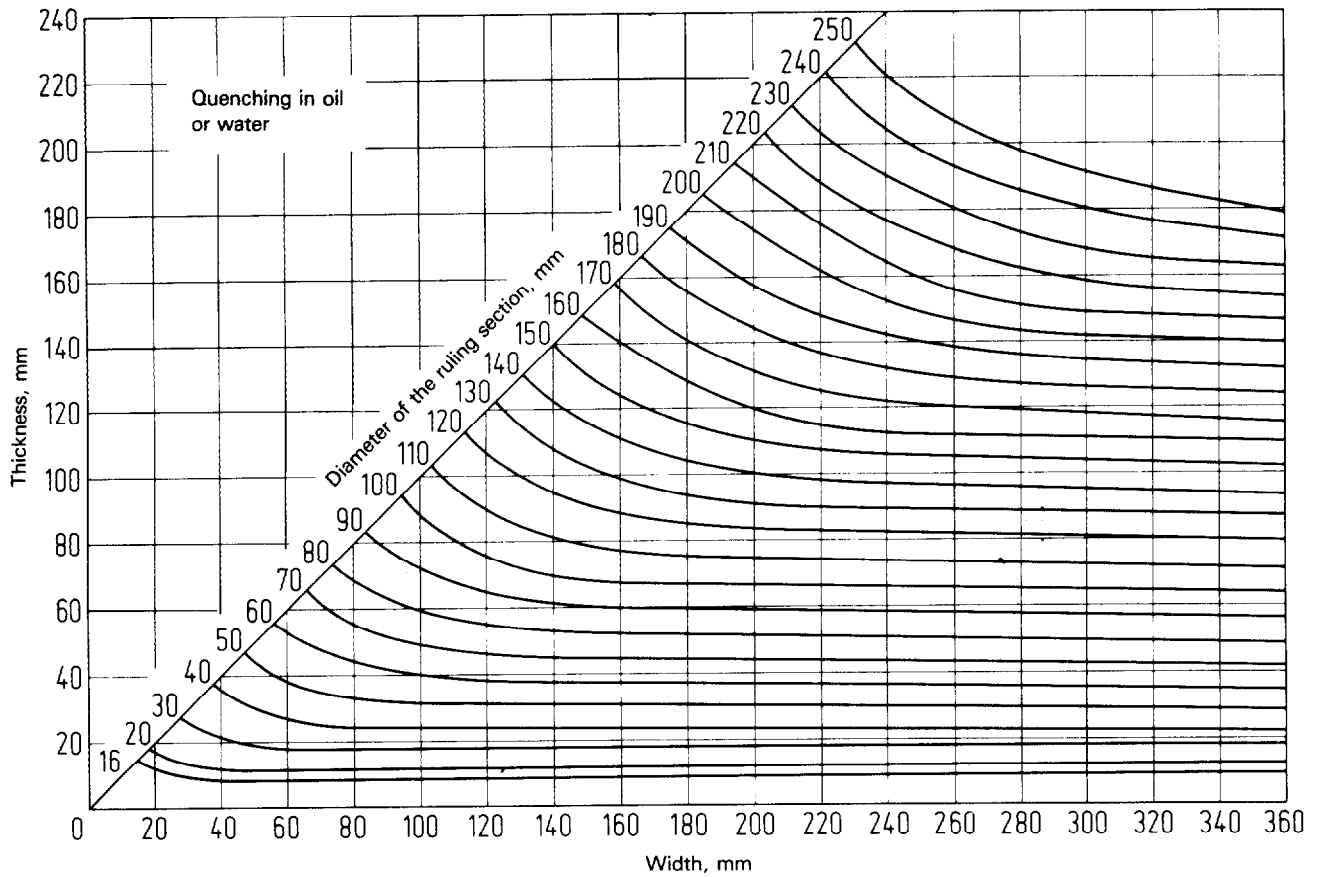

Figure 2 — Diameter of the ruling section of square and rectangular bars

Example: For a rectangular bar with a cross-section of 40 mm × 60 mm, the diameter of the ruling section is 50 mm.

## Annex B

### Supplementary or special requirements

(This annex forms an integral part of the Standard.)

NOTE — One or more of the following supplementary or special requirements shall be applied but only when specified in the enquiry and order. Details of these requirements shall, where necessary, be agreed upon by the manufacturer and purchaser at the time of enquiry and order.

#### B.1 Mechanical properties of reference test pieces in the quenched and tempered condition

For deliveries of steels for quenching and tempering, in a condition other than quenched and tempered, the requirements for the mechanical properties in the quenched and tempered condition (see table 7) shall be verified on a reference test piece.

In the case of bars, wire rods and bright steel the sample to be quenched and tempered shall, unless otherwise agreed, have the cross-section of the product. In all other cases, the dimensions and the manufacture of the sample shall be agreed at the time of enquiry and order where appropriate, taking into consideration the indications for the determination of the ruling section given in annex A. The samples shall be quenched and tempered in accordance with the conditions given in table 9 or as agreed at the time of enquiry and order. The details of the heat treatment shall be given in the document. Unless otherwise agreed, the test pieces shall be taken in accordance with the relevant specifications of the standard.

#### B.2 Mechanical properties of reference test pieces in the simulated case-hardened condition

**B.2.1** The values for the mechanical properties in the simulated case-hardened condition (see table 6) shall be verified on

a reference test piece. The values of table 6 apply to test pieces taken on simulated case-hardened rounds tested in accordance with ISO 6892 (tensile test). The details of simulated case-hardening shall be agreed.

**B.2.2** The reference test bar shall be manufactured by hot-forging the test sample to the next-smallest diameter of reference test bar, i.e. to 16 or 30 mm diameter. The test pieces shall be taken from the test bar in the longitudinal direction. The axes of test pieces shall correspond to the axes of 16 mm and 30 mm test bars.

#### B.3 Product analysis

One product analysis shall be carried out per cast for the determination of all elements for which values are specified for the cast analysis of the steel type concerned.

The conditions for sampling shall be in accordance with ISO 377. In cases of dispute, the analysis shall be carried out, if possible, according to the appropriate internationally standardized method.

#### B.4 Special agreements for marking

The products shall be marked in a way specially agreed at the time of enquiry and order.

## Annex C

### List of related International Standards

(This annex does not form an integral part of the Standard.)

International Standards covering types of steel similar to those in table 3, but destined for other products or treatment conditions or special applications :

ISO 683, *Heat-treated steels, alloy steels and free-cutting steels*

— *Part 17: Ball and roller bearing steels.*

— *Part 18: Wrought unalloyed steels in the normalized, or normalized and cold-drawn, or hot-rolled and cold-drawn condition.*<sup>1)</sup>

ISO 2938, *Hollow steel bars for machining.*

ISO 4954, *Steels for cold heading and cold extruding.*

---

1) When this part of ISO 683 is revised, the revised standard will no longer cover the normalized condition.

---

#### UDC 669.14.018.23-13

**Descriptors :** steels, heat treatable steels, alloy steels, free machining steels, iron- and steel products, wrought products, specifications, acceptance testing, designation, marking.

Price based on 14 pages

---